

---

# INGERSOLL-RAND®

---

## OPERATING, MAINTENANCE, PARTS MANUAL

### COMPRESSOR MODEL

**P185WIR**

**XP185WIR**

**Code: A**



**This manual contains important safety information.**

**Do not destroy this manual.**

**This manual must be available to the personnel who operate and maintain this machine.**

Doosan purchased Bobcat Company from Ingersoll-Rand Company in 2007. Any reference to Ingersoll-Rand Company or use of trademarks, service marks, logos, or other proprietary identifying marks belonging to Ingersoll-Rand Company in this manual is historical or nominative in nature, and is not meant to suggest a current affiliation between Ingersoll-Rand Company and Doosan Company or the products of either.

**INGERSOLL-RAND®**

**AIR COMPRESSORS**

Portable Air Compressor Division  
P.O. Box 868 - 501 Sanford Ave  
Mocksville, N.C. 27028

---

# ***QUALITY POLICY***

*We will supply products and services that consistently meet the requirements of our customers and each other.*

## **CALIFORNIA**

### **Proposition 65 Warning**

**Diesel engine exhaust and some of its constituents are known to the State of California to cause cancer, birth defects, and other reproductive harm.**

---

# Foreword

Machine models represented in this manual may be used in various locations worldwide. Machines sold and shipped into European common market countries requires that the machine display the EC Mark and conform to various directives. In such cases, the design specification of this machine has been certified as complying with EC directives. Any modification to any part is absolutely prohibited and would result in the CE certification and marking being rendered invalid. A declaration of that conformity follows:

## ***Declaration of Conformity***

**WITH EC DIRECTIVE**

**98/37/EC**

**Ingersoll-Rand Company  
P.O. Box 868  
501 Sanford Avenue  
Mocksville, North Carolina 27028**

**We  
Represented In EC By:**

**Ingersoll-Rand Company Limited  
Swan Lane, Hindley Green  
Wigan WN2 4EZ  
United Kingdom**

**Declare that, under our sole responsibility for manufacture and supply, the product(s)**

HP1300WCU	VHP825WCU	XHP900WCAT	VHP750WCAT	XHP1070CAT
XP1400WCU	HP935WCU	XHP650WCAT	VHP850WCAT	NXP1300WCU
P1600WCU	XP1050WCU	XHP750WCAT	HP900WCAT	
XP900WCU	HP825WCU	XHP825WCAT	XP1000WCAT	

**To which this declaration relates, is (are) in conformity with the provisions of the above directives using the following principal standards**

**EN1012-1, EN29001, EN202, EN60204-1  
PN8NTC2, EN 50081, EN50082**

**Issued at Mocksville on 1-1-95**

  
\_\_\_\_\_  
**Ric Lunsford  
Manager of Quality Control**

**Issued at Hindley Green on 1-1-95**

  
\_\_\_\_\_  
**H. Seddon, Q.A. Manager**

---

Nothing contained in this document is intended to extend any promise, warranty or representation, expressed or implied, regarding the Ingersoll-Rand products described herein. Any such warranties or other terms and conditions of sale of products shall be in accordance with the standard terms and conditions of sale for such products, which are available upon request.

This manual contains instructions and technical data to cover all routine operation and scheduled maintenance tasks by operation and maintenance staff. Major overhauls are outside the scope of this manual and should be referred to an authorized Ingersoll-Rand service department.

All components, accessories, pipes and connectors added to the compressed air system should be:

- of good quality, procured from a reputable manufacturer and, wherever possible, be of a type approved by Ingersoll-Rand.
- clearly rated for a pressure at least equal to the machine maximum allowable working pressure.
- compatible with the compressor lubricant/coolant.
- accompanied with instructions for safe installation, operation and maintenance.

Details of approved equipment are available from Ingersoll-Rand Service departments.

The use of repair parts other than those included within the Ingersoll-Rand approved parts list may create hazardous conditions over which Ingersoll-Rand has no control. Therefore, Ingersoll-Rand cannot be held responsible for equipment in which non-approved repair parts are installed.

Ingersoll-Rand reserves the right to make changes and improvements to products without notice and without incurring any obligation to make such changes or add such improvements to products sold previously.

The intended uses of this machine are outlined below and examples of unapproved usage are also given. However, Ingersoll-Rand cannot anticipate every application or work situation that may arise. **If in doubt, consult supervision.**

This machine has been designed and supplied for above ground operation to be used for compression of normal ambient air containing no additional gases, vapors or particles within the ambient temperature range specified in the general data section of this manual.

**This machine should not be used:**

- A. For direct or indirect human consumption of the compressed air.
- B. Outside the ambient temperature range specified in the general data section of this manual.
- C. When an actual or foreseeable risk of hazardous levels of flammable gases or vapors exists.
- D. With other than Ingersoll-Rand approved components.
- E. With guards, or controls or switches missing or disabled.
- F. For storage or transportation of materials inside or on the enclosure.

This company accepts no responsibility for errors in translation of this manual from the original English version.

---

# TABLE OF CONTENTS

<b>SECTION 1</b>	<b>SAFETY</b>
<b>SECTION 2</b>	<b>WARRANTY/REGISTRATION</b>
<b>SECTION 3</b>	<b>NOISE EMISSION</b>
<b>SECTION 4</b>	<b>GENERAL DATA</b>
<b>SECTION 5</b>	<b>OPERATION</b>
<b>SECTION 6</b>	<b>MAINTENANCE</b>
<b>SECTION 7</b>	<b>LUBRICATION</b>
<b>SECTION 8</b>	<b>TROUBLESHOOTING</b>
<b>SECTION 9</b>	<b>ENGINE (operation, maintenance, lubrication, troubleshooting)</b>
<b>SECTION 10</b>	<b>PARTS ORDERING</b>
<b>SECTION 11</b>	<b>PARTS LIST</b>
<b>SECTION 12</b>	<b>OPTIONS PARTS LIST</b>

# **IMPORTANT** **NOTICE**

This machine may have been shipped from the factory with the drawbar positioned upright.

## To Convert From Shipping Position to Towing Position

The following tools are required:

- Ratchet
- 13mm socket to fit ratchet
- Torque wrench set to 68 foot pounds  
(9.4 kg-meters)
- 16mm socket to fit torque wrench
- 5 inch extension for torque wrench

### Hardware Included:

- (4) 12mm bolts with pre-applied thread lock
- (2) 8mm Taptite Bolts
- (2) Washers
- (2) Safety Chains

1. Remove hardware box from compressor toolbox.
2. Open box and remove the bag containing hardware, safety chains and assembly instructions.
3. Using the jack, raise the front of the unit so that the legs are approximately 1" above the ground.
4. Remove the temporary retaining bolts from both sides of the frame at the drawbar connection (See Figure 1).
5. Carefully lower drawbar to the Level Position.
6. Install the four bolts (with pre-applied thread lock) to the four points inside the enclosure and torque to 68 ft. lbs. (9.4 kg-m) (See Figure 2).
7. Install safety chains by sliding the second link of one chain into the slot in drawbar plate. Fasten chain to plate using taptite and washer. Repeat for the other chain (See Sketch).

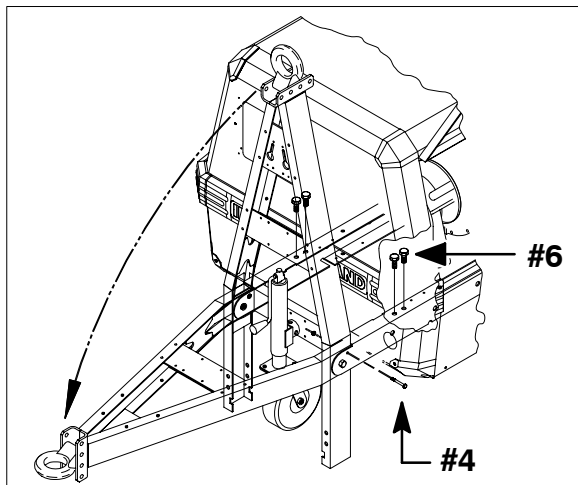

**Figure 1**  
**Drawbar Position**

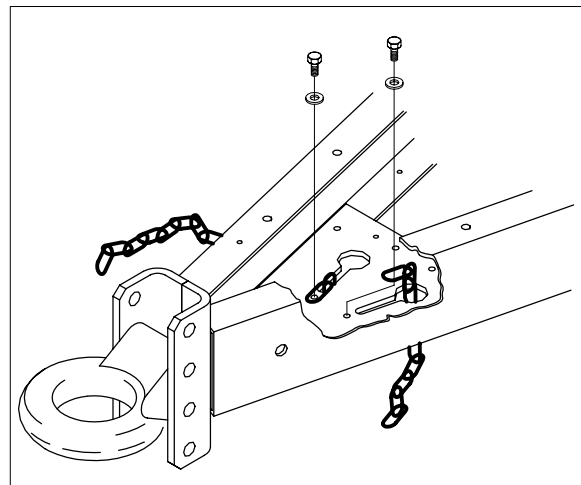

**Figure 2**  
**Safety Chain Attachment**

---

# SECTION 1- SAFETY

## SAFETY PRECAUTIONS

### **General Information**

Ensure that the operator reads and understands the decals and consults the manuals before maintenance or operation.

Ensure that the Operation and Maintenance manual, and the manual holder if equipped, are not removed permanently from the machine.

Ensure that maintenance personnel are adequately trained, competent and have read the manuals.

Make sure that all protective covers are in place and that the canopy/doors are closed during operation.

The specification of this machine is such that the machine is not suitable for use in flammable gas risk areas. If such an application is required then all local regulations, codes of practice and site rules must be observed. To ensure that the machine can operate in a safe and reliable manner, additional equipment such as gas detection, exhaust spark arrestors, and intake (shut-off) valves may be required, dependent on local regulations or the degree of risk involved.

Air discharged from this machine may contain carbon monoxide or other contaminants which will cause serious injury or death. Do not breathe this air.

Compressed air can be dangerous if incorrectly handled. Before doing any work on the unit, ensure that all pressure is vented from the system and that the machine cannot be started accidentally.

Ensure that the machine is operating at the rated pressure and that the rated pressure is known to all relevant personnel.

All air pressure equipment installed in or connected to the machine must have safe working pressure ratings of at least the machine safety valve rating.

If more than one compressor is connected to one common downstream plant, effective check valves and isolation valves must be fitted and controlled by work procedures, so that one machine cannot accidentally be pressurized or over pressurized by another.

Compressed air must not be used for a feed to any form of breathing apparatus or mask.

The discharged air contains a very small percentage of compressor lubricating oil and care should be taken to ensure that downstream equipment is compatible.

If the discharged air is to be ultimately released into a confined space, adequate ventilation must be provided.

When using compressed air, always use appropriate personal protective equipment.

All pressure containing parts, especially flexible hoses and their couplings, must be regularly inspected, be free from defects and be replaced according to the Manual instructions.

Avoid bodily contact with compressed air.

Never operate unit without first observing all safety warnings and carefully reading the operation and maintenance manual shipped from the factory with this machine.

Never operate the engine of this machine inside a building without adequate ventilation. Avoid breathing exhaust fumes when working on or near the machine. Do not alter or modify this machine.

A battery contains sulfuric acid and can give off gases which are corrosive and potentially explosive. Avoid contact with skin, eyes and clothing. In case of contact, flush area immediately with water.

Exercise extreme caution when using booster battery. To jump battery, connect ends of one booster cable to the positive (+) terminal of each battery. Connect one end of other cable to the negative (-) terminal of the booster battery and other end to a ground connection away from dead battery (to avoid a spark occurring near any explosive gases that may be present). After starting unit, always disconnect cables in reverse order.

Never operate unit without first observing all safety warnings and carefully reading the operation and maintenance manual shipped from the factory with this machine.

---

This machine may include such materials as oil, diesel fuel, antifreeze, brake fluid, oil/air filters and batteries which may require proper disposal when performing maintenance and service tasks. Contact local authorities for proper disposal of these materials.

High Pressure Air can cause serious injury or death. Relieve pressure before removing filler plugs/caps, fittings or covers.

Air pressure can remain trapped in air supply line which can result in serious injury or death. Always carefully vent air supply line at tool or vent valve before performing any service.

This machine produces loud noise with the doors open or service valve vented. Extended exposure to loud noise can cause hearing loss. Always wear hearing protection when doors are open or service valve is vented.

Never inspect or service unit without first disconnecting battery cable(s) to prevent accidental starting.

Do not remove the pressure cap from a HOT radiator. Allow radiator to cool down before removing pressure cap.

Do not use petroleum products (solvents or fuels) under high pressure as this can penetrate the skin and result in serious illness. wear eye protection while cleaning unit with compressed air to prevent debris from injuring eye(s).

Disconnected air hoses whip and can cause serious injury or death. Always attach a safety flow restrictor to each hose at the source of supply or branch line in accordance with OSHA Regulation 29CFR Section 1926.302(b).

Hot pressurized fluid can cause serious burns. Do not open radiator while hot.

Rotating fan blade can cause serious injury. Do not operate without guard in place.

Use care to avoid contacting hot surfaces (engine exhaust manifold and piping, air receiver and air discharge piping, etc.).

Ether is an extremely volatile, highly flammable gas. USE SPARINGLY! Do NOT use ETHER if unit has GLOW Plug starting aid. Engine damage will result.

Never allow the unit to sit stopped with pressure in the receiver-separator system. As a precaution, open the manual blowdown valve.

Never operate unit with guards, covers or screens removed. Keep hands, hair, clothing, tools, blow gun tips, etc. well away from moving parts.

Make sure wheels, tires and tow bar connectors are in safe operating condition and tow bar is properly connected before towing.

Whenever the machine is stopped, air will flow back into the compressor system from devices or systems downstream of the machine unless the service valve is closed. Install a check valve at the machine service valve to prevent reverse flow in the event of an unexpected shutdown when the service valve is open.

### **Hazardous Substance Precaution**

The following substances are used in the manufacture of this machine and may be hazardous to health if used incorrectly.

**Precaution:** Avoid ingestion, skin contact and breathing fumes for the following substances: Antifreeze, Compressor Oil, Engine Lubricating Oil, Preservative Grease, Rust Preventative, Diesel Fuel and Battery Electrolyte.

The following substances may be produced during the operation of this machine and may be hazardous to health:

Avoid build-up of Engine Exhaust Fumes in confined spaces.

Avoid breathing Exhaust Fumes.

Avoid breathing Brake Lining Dust during maintenance.



# **SAFETY LABELS**

Look for these signs on machines shipped to international markets outside North America, which point out potential hazards to the safety of you and others. Read and understand thoroughly. Heed warnings and follow instructions. If you do not understand, inform you supervisor.



**Corrosion risk**



**Hot Surface**

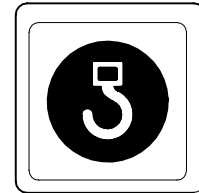

**Lifting point**

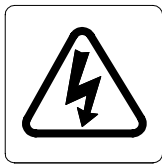

**WARNING: Electrical shock risk.**

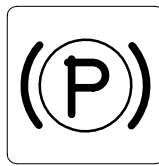

**Parking Brake**



**No open flame**

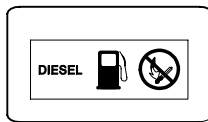

**Diesel Fuel.  
No open flame.**

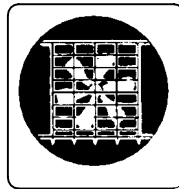

**Do not operate the machine  
without guard being fitted.**



**Lifting point**



**WARNING - Flammable liquid.**

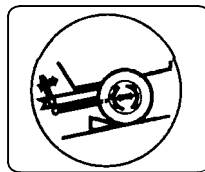

**When parking use prop stand,  
handbrake and wheel chocks.**

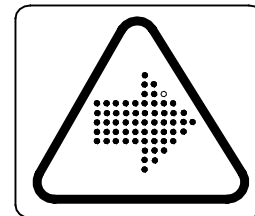

**Air/gas flow or Air discharge.**



**WARNING - Hot and harmful exhaust gas.**



**Tie down point**

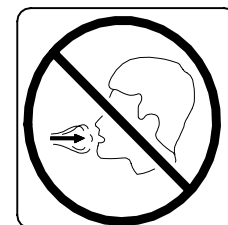

**Do not breathe the compressed  
air from this machine.**



Read the Operation and Maintenance manual before operation or maintenance of this machine is undertaken.

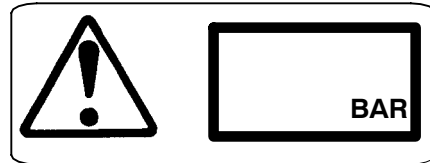

**WARNING - Maintain correct tire pressure.** (Refer to the *GENERAL INFORMATION* section of this manual).

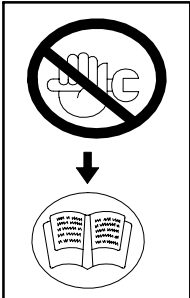

**WARNING:** Consult the operation and maintenance manual before performing any maintenance.



**Rough Service Designation  
Wet Location Operation**

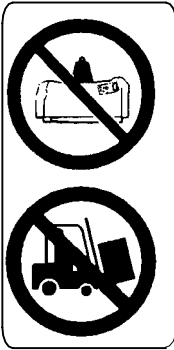

**Do not stack**

**Do not use fork lift truck from this side**

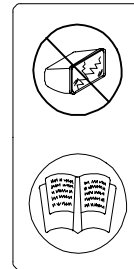

**Replace any cracked protective shield.**

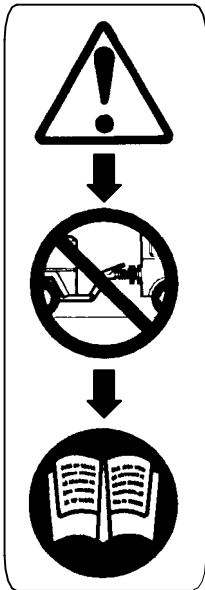

**Do not operate with the doors or enclosure open.**

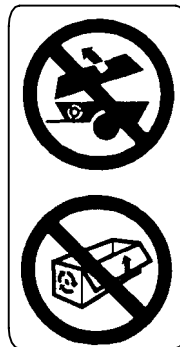

**On (power).**



**Off (power).**

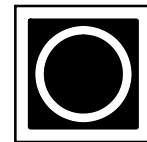

**Emergency stop.**

**WARNING - Before connecting the tow bar or when preparing to tow, consult the operation and maintenance manual.**

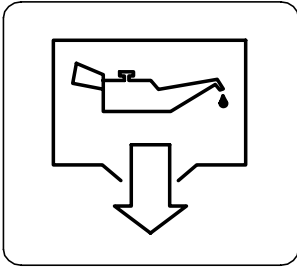

Oil Drain

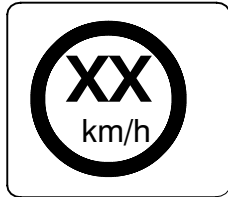

Do not exceed the speed limit.

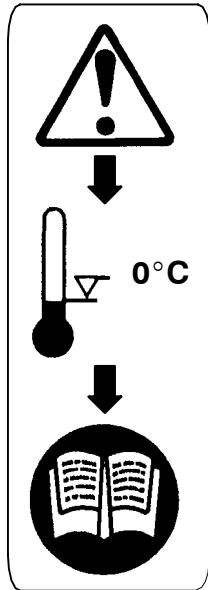

**WARNING** - For operating temperature below 0°C, consult the operation and maintenance manual.

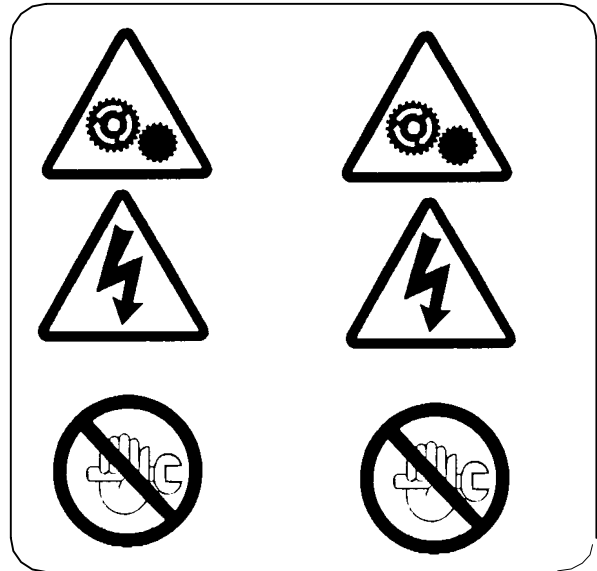

**WARNING** - Do not undertake any maintenance on this machine until the electrical supply is disconnected and the air pressure is totally relieved.



Read the Operation and Maintenance manual before operation or maintenance of this machine is undertaken



Do not remove the Operating and Maintenance manual and manual holder from this machine.

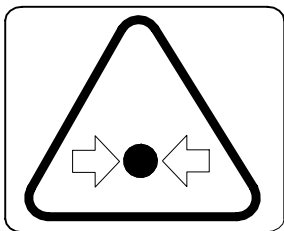

Pressurized vessel.



Use fork lift truck from this side only.

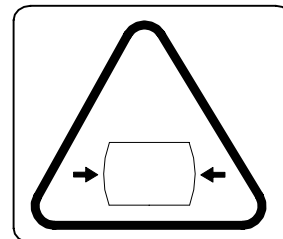

Pressurized component or system.

Look for these signs on machines shipped to markets in North America, which point out potential hazards to the safety of you and others. Read and understand thoroughly. Heed warnings and follow instructions. If you do not understand, inform you supervisor.



(Red Background)

Indicates the presence of a hazard which WILL cause serious injury, death or property damage, if ignored.



(Orange Background)

Indicates the presence of a hazard which CAN cause serious injury, death or property damage, if ignored.



(Yellow Background)

Indicates the presence of a hazard which WILL or can cause injury or property damage, if ignored.



(Blue Background)

Indicates important set-up, operating or maintenance information.

<b>DANGER</b>
<p><b>Discharged air can contain carbon monoxide or other contaminants.</b>  <b>Will cause serious injury or death.</b>          Do not breathe this air.</p>

<b>WARNING</b>	
<p><b>Trapped air pressure.</b>  <b>Can cause serious injury or death.</b></p> <p>Close service valve and operate tool to vent trapped air before performing any service.</p>	

<b>WARNING</b>		
<p><b>Hot pressurized fluid.</b>  <b>Can cause serious burns.</b></p> <p>Do not open radiator while hot.</p>		

<b>WARNING</b>	
<p><b>High pressure air.</b>  <b>Can cause serious injury or death.</b></p> <p>Relieve pressure before removing filler plugs/caps, fittings or covers.</p>	



## ⚠ WARNING

**Improper operation of this equipment.  
Can cause serious injury or death.**  
Read Operator's Manual supplied with this machine before operation or servicing.

**Modification or alteration of this machine.  
Can cause serious injury or death.**  
Do not alter or modify this machine without the express written consent of the manufacturer.



## ⚠ WARNING

**Collapsing jackstand.  
Can cause serious injury.**  
Insert locking pin completely.



**Excessive towing speed.  
Can cause serious injury or death.**  
Do NOT exceed 65 mph (105 km/hr.)

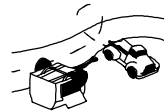

## ⚠ WARNING

**Rotating fan blade.  
Can cause serious injury.**

Do not operate without guard in place.

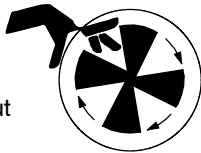

## ⚠ WARNING

**Falling off machine.  
Can cause serious injury or death.**

Access lifting bail from inside machine.



## ⚠ WARNING

**Door under pressure.  
Can cause serious injury.**

Use both hands to open door when machine is running.

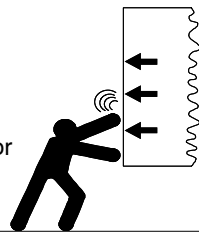

## ⚠ WARNING

**Disconnected air hoses whip.  
Can cause serious injury or death.**

When using air tools attach safety device (OSHA Valve) at source of air supply for each tool.

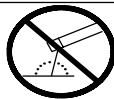

## CAUTION

**DO NOT WELD.  
ELECTRONIC DAMAGE  
WILL OCCUR.**

This engine is equipped with an electronic engine controller and other electronic components.



## ⚠ WARNING

**Combustible gas.  
Can cause serious burns,  
blindness or death.**

Keep sparks and open flames away from batteries.





## CAUTION

**DO NOT USE ETHER.**

**ENGINE DAMAGE WILL OCCUR.**

This engine is equipped with an electric heater starting aid.

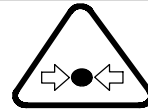

## WARNING

**High pressure air.  
Can cause serious  
injury or death.**

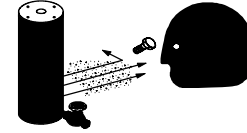

Relieve pressure before removing filler plugs/caps, fittings or covers.



## USE DIESEL FUEL ONLY

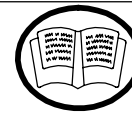

## NOTICE

### COOLANT FILL INSTRUCTIONS

#### Adding:

Do NOT remove radiator cap. Top off at overflow reservoir. Use same anti-freeze mixture as in radiator.

#### Replacing:

With system cool, remove radiator cap. Drain coolant and close drain. At radiator, refill system. Replace radiator cap. At reservoir, fill to "Hot" level. Run for 30 minutes. Stop and allow to cool. At reservoir, add coolant as necessary to reach "Cold" level.

## FREE SAFETY DECALS!

To promote communication of Safety Warnings on products manufactured by the Portable Compressor Division in Mocksville, N.C., Safety Decals are available **free** of charge. Safety decals are identified by the decal heading: **DANGER, WARNING or CAUTION.**

Decal part numbers are on the bottom of each decal and are also listed in the compressor's parts manual. Submit orders for Safety Decals to the Mocksville Parts Service Department. The no charge order should contain only Safety Decals. Help promote product safety! Assure that decals are present on the machines. Replace decals that are not readable.

---

## SECTION 2 - Warranty

Ingersoll-Rand, through its distributor, warrants that each item of equipment manufactured by it and delivered hereunder to the initial user will be free of defects in material and workmanship for a period of three (3) months from initial operation or six (6) months from the date of shipment to the initial user, whichever occurs first.

With respect to the following types of equipment, the warranty period enumerated below will apply in lieu of the foregoing warranty period.

- A. **Aftercoolers** - The earlier of nine (9) months from date of shipment to or six (6) months from start up by initial user.
- B. **Portable Compressors, Portable Generator Sets (GENSET) 8KW, 11KW, 20KVA thru 575KVA, Portable Light Towers and Air Dryers** - The earlier of twelve (12) months from shipment to or the accumulation of 2,000 hours of service by the initial user.  
**3.5KW thru 7.0KW and 10KW** - The earlier of twelve (12) months from shipment to or the accumulation of 2,000 hours of service by the initial user, whichever occurs first. Ingersoll-Rand will provide a new part or repaired part, at it's election, in place of any part which is found to be defective in material or workmanship during the period described above. Labor cost to replace the part is the responsibility of the user.
- C. **Portable Compressor Air Ends** - The earlier of twenty-four (24) months from shipment to or the accumulation of 4,000 hours of service by the initial user. For Air Ends, the warranty against defects will include replacement of the complete Air End, provided the original Air End is returned assembled and unopened.
- C.1 **Portable Compressor Airend Limited Optional Warranty** - The earlier of sixty (60) months from shipment to or the accumulation of 10,000 hours of service. The optional warranty is limited to defects in rotors, housings, bearings and gears and provided all the following conditions are met:
  - 1. The original air end is returned assembled and unopened.
  - 2. Continued use of genuine Ingersoll-Rand parts, fluids, oil and filters.
  - 3. Maintenance is performed at prescribed intervals.**Oil-Free airends are fee-based and may require a maintenance agreement. Formal enrollment is required.**
- D. **Genset Generators 8KW, 11KW, 20KVA thru 575KVA** - The earlier of twenty-four (24) months from shipment to or the accumulation of 4,000 hours of service by the initial user.  
**3.5KW thru 7.0KW and 10KW** - The earlier of twelve (12) months from shipment to or the accumulation of 2,000 hours of service.
- E. **Portable Light Tower Generators**- The earlier of twelve (12) months from shipment to or the accumulation of 2,000 hours of service by the initial user. Light Source model only, the earlier of twenty-four (24) months from shipment to or the accumulation of 4,000 hours of service.
- F. **Ingersoll-Rand Engines** - The earlier of twenty-four (24) months from shipment to or the accumulation of 4,000 hours of service.

---

G. **Ingersoll-Rand Platinum Drive Train Warranty (Optional)** – Platinum drive train pertains to the Ingersoll-Rand Engine and Airend combination. The earlier of sixty (60) months from shipment to, or the accumulation of 10,000 hours of service. The starter, alternator, fuel injection system and all electrical components are excluded from the extended warranty. The airend seal and drive coupling are included in the warranty (airend drive belts are not included). The optional warranty is automatically available when meeting the following conditions:

1. The original airend is returned assembled and unopened.
2. Continued use of genuine Ingersoll-Rand parts, fluids, oil and filters.
3. Maintenance is performed at prescribed intervals.

It is the obligation of the user to provide verification that these conditions have been satisfied when submitting warranty claims.

F. **Spare Parts**– Six (6) months from date of shipment.

Ingersoll-Rand will provide a new part or repaired part, at its election, in place of any part which is found upon its inspection to be defective in material and workmanship during the period prescribed above. Such part will be repaired or replaced without charge to the initial user during normal working hours at the place of business of an Ingersoll-Rand distributor authorized to sell the type of equipment involved or other establishment authorized by Ingersoll-Rand. User must present proof of purchase at the time of exercising warranty.

The above warranties do not apply to failures occurring as a result of abuse; misuse, negligent repairs, corrosion, erosion and normal wear and tear, alterations or modifications made to the product without express written consent of Ingersoll-Rand; or failure to follow the recommended operating practices and maintenance procedures as provided in the product's operating and maintenance publications.

Accessories or equipment furnished by Ingersoll-Rand, but manufactured by others, including, but not limited to, engines, tires, batteries, engine electrical equipment, hydraulic transmissions, carriers, shall carry whatever warranty the manufacturers have conveyed to Ingersoll-Rand and which can be passed on to the initial user.

THIS WARRANTY IS IN LIEU OF ALL OTHER WARRANTIES EXPRESSED OR IMPLIED, (EXCEPT THAT OF TITLE), AND THERE ARE NO WARRANTIES OF MERCHANTABILITY OR OF FITNESS FOR A PARTICULAR PURPOSE.



# GENERAL WARRANTY INFORMATION

GENERAL WARRANTY			Extended Coverage
Portable Compressor	Package	1 year/2000 hours	
	Airend	2 years/4000 hours	5 years/10,000 hours Limited warranty, major components (refer to operator's manual).

Portable Genset 8KW, 11KW, 20KVA thru 575KVA	Package	1 year/2000 hours	None
	Generator	2 years/4000 hours	None

Portable Genset 3.5KW thru 7.0KW and 10KW	Package	1 year/2000 hours PARTS ONLY	None
	Generator	1 year/2000 hours PARTS ONLY	None

Light Tower	Package	1 year/2000 hours	
	Generator	1 year/2000 hours	2 years/4000 hours, for Lightsource introduced 8/16/99.

ENGINES			
	Months	Hours	Extended Coverage
Caterpillar	12	No Limit	Available at dealer
Cummins	24	2000	Major components 3 yrs/10,000 hours - available at dealer
John Deere (IN COMPRESSORS)	24	2000	5 yrs/5000 hours using OEM fluids & filters with \$250 deductible. 2 yrs/4000 hours using IR fluids & filters
(IN GENERATORS AS OF 1/1/01)	24	2000	
Deutz	24	2000	Available at dealer
Ingersoll-Rand	24	4000	5 years/10,000 hours when using genuine Ingersoll-Rand fluids and parts. Refer to operator's manual.
Kubota (North America Only)	24	2000	Major components 36 months/3000 hrs - parts only
(Western Europe & Oceania)	24	2000	None
(Central & South America, Asia, Middle East & Africa)	12	1000	None
Mitsubishi	24	2000	2 years/4000 hours using IR fluids and filters
Volvo	24	2000	2 years/4000 hours using IR fluids and filters
Honda	12	unlimited	None
Vanguard	24	unlimited	None

PARTS			
	Months	Hours	Coverage
Ingersoll-Rand	6	No Limit	Parts Only

AIREND EXCHANGE			
	Months	Hours	Extended Coverage
Airend	12	2000 hours	2 years/4000 hours - available from IR.

Note: Actual warranty times may change. Consult the manufacturer's warranty policy as shipped with each new product.

## Extended Limited Airend Warranty

Ingersoll-Rand Portable Compressor Division is pleased to announce the availability of extended limited airend warranty. Announcement of the extended warranty coincides with the introduction of PRO•TEC™ Compressor Fluid. PRO•TEC™ Compressor Fluid is an amber colored fluid specially formulated for Portable Compressors and is being provided as the factory filled fluid for all machines except 1 XHP650/900/1070 models.

All machines have the standard airend warranty - *The earlier of 24 months from shipment to, or the accumulation of 4000 hours of service.*

The warranty against defects will include replacement of the complete airend, provided the original airend is returned assembled and unopened.

The optional limited warranty is the earlier of 60 months from shipment to, or the accumulation of 10,000 hours of service. The optional warranty is limited to defects in major components (rotors, housings, gears, bearings), and is automatically available when the following three conditions are met:

1. The original airend is returned assembled and unopened.
2. Submissions of proof that Ingersoll-Rand fluid, filters and separators have been used. Refer to the Operation and Parts manual for the correct fluids, filters and separator elements required.
3. Submission of proof that maintenance intervals have been followed.

<b>WARRANTY</b>	<b>TIME</b>	<b>*BARE AIREND</b>	<b>** AIREND COMPONENTS</b>
<b>STANDARD</b>	<b>2 yrs/4000 hrs</b>	<b>100% parts and labor</b>	<b>100% parts and labor</b>
<b>OPTIONAL</b>	<b>5 yrs/10,000 hrs</b>	<b>100% parts and labor</b>	<b>0%</b>

\* Bare Airend - pertains to major airend parts (rotors, housings, gears and bearings).

\*\* Airend Components - pertains to auxiliary attachments to the bare airend (drive coupling, seals, pumps, valves, tubes, hoses, fittings and filter housing).

**PRO•TEC™ and XHP505 Compressor Fluids are available from the Mocksville Product Support department by calling 1-800-633-5206.**

<sup>1</sup> XHP650/900/1070 will continue to use XHP505 and will have the extended warranty when above conditions are met.

---

# ***WARRANTY REGISTRATION***

## **Complete Machine Registration**

Machines shipped to locations within the United States do not require a warranty registration unless the machine status changes (i.e. change of ownership).

Machines shipped outside the United States require notification be made to initiate the machine warranty.

**Fill out the Warranty Registration Form in this section, keep a copy for your records and mail form to:**

Ingersoll-Rand Company  
Portable Compressor Division  
P.O. Box 868  
Mocksville, North Carolina 27028  
Attn: Warranty Department

**Note: Completion of this form validates the warranty.**

<u>Selling Distributor</u>	<u>Servicing Distributor</u>	<b>WARRANTY REGISTRATION</b>	
Name _____	Name _____	Owner/User Name _____	
Address _____	Address _____	Address _____	
City _____	City _____	City _____	
County _____	County _____	County _____	
State _____	State _____	State _____	
Zip Code _____	Zip Code _____	Zip Code _____	
Telephone _____	Telephone _____	Telephone _____	

**Complete the Applicable Blocks**  
**Owner/User Type of Business (check one only)**

<input type="checkbox"/> Construction-Heavy (highway, excavation, etc.)	<input type="checkbox"/> Asphalt Contractor	<input type="checkbox"/> Coal Mining	<input type="checkbox"/> Other Mining
<input type="checkbox"/> Construction-Light (carpentry, plumbing, pools, mason, etc.)	<input type="checkbox"/> Government (municipal, state, county, etc.)	<input type="checkbox"/> Quarry	<input type="checkbox"/> Shallow Oil & Gas
<input type="checkbox"/> Rental (rental center, rental fleet, etc.)	<input type="checkbox"/> Building Contractor	<input type="checkbox"/> Waterwell	<input type="checkbox"/> Utility Company (gas, electric, water, etc.)
<input type="checkbox"/> Industrial (plant use)	<input type="checkbox"/> Other specify _____	<input type="checkbox"/> Exploration	<input type="checkbox"/> Utility Contractor

<b>Model</b>	<b>Unit S/N</b>	<b>Engine S/N</b>	<b>Date Delivered</b>
<b>Unit-Hours</b>	<b>Airend S/N</b>	<b>Truck S/N</b>	<b>Truck Engine S/N</b>

**SERVICING DISTRIBUTOR/USER ACKNOWLEDGEMENT**

1. The Purchaser has been instructed and/or has read the manual and understands proper preventative maintenance, general operation and safety precautions.
2. The warranty and limitation of liability has been reviewed and understood by the owner/user.
3. In the event that this unit is to be used within a nuclear facility, the owner/user shall notify Ingersoll-Rand of such use so that Ingersoll-Rand may arrange for appropriate nuclear liability protection from the owner-licensee of the facility.
4. Ingersoll-Rand reserves the right to make design changes or modifications of Ingersoll-Rand products at anytime without incurring any obligation to make similar changes or modifications on previously sold units.

---

*Attention: Warranty Department*

*Ingersoll-Rand Company  
Portable Compressor Division  
P.O. Box 868  
Mocksville, North Carolina 27028*

-----  
*fold*  
-----

---

## CALIFORNIA EMISSION CONTROL WARRANTY STATEMENT

### EMISSION RELATED SYSTEM DEFECT WARRANTY

Ingersoll-Rand Company warrants to the initial owner and subsequent owner of a certified non-road diesel engine (powering non-road machines and equipment), that the engine is:

1. Designed, built, and equipped so as to conform, at the time of sale, with all applicable regulations adopted by the United States Environmental Protection Agency (EPA) and the California Air Resource Board.
2. Free from defects in materials and workmanship in specific emission related parts for a period of five (5) years or 3,000 hours of operation whichever occurs first, after date of delivery to the initial owner.

If an emission related part fails during the warranty period, it will be repaired or replaced. Any such part repaired or replaced under warranty is warranted for the remainder of the warranty period.

During the term of this warranty, Ingersoll-Rand Company will provide repair or replacement of any warranted part at no charge to the non-road engine owner.

In an emergency, repairs may be performed at any service establishment, or by the owner, using any replacement part.

Ingersoll-Rand Company will reimburse the owner for their expenses, including diagnostic charges for such emergency repair. These expenses shall not exceed Ingersoll-Rand Company suggested retail price for all warranted parts replaced, and labor charges based on Ingersoll-Rand Company recommended time allowance for the warranty repair and the geographically appropriate hourly labor rate.

A part not being available within 30 days constitutes an emergency.

As a condition of reimbursement, replaced parts and receipted invoices must be presented at a place of business of Ingersoll-Rand Company or other establishment authorized by Ingersoll-Rand Company.

This warranty covers the following emission related parts and components.

- Charge Air Cooling System (If Equipped)
- Fuel Injection System
- Intake Manifold

- Exhaust Manifold
- Turbocharger System
- Miscellaneous hoses, clamps, connectors and sealing devices used in the above systems.

If failure of one of these components results in failure of another part, both will be covered by this warranty. Any Replacement part may be used for maintenance or repairs. The owner should ensure that such parts are equivalent in design and durability to genuine INGERSOLL-RAND parts.

Use of non-genuine INGERSOLL-RAND parts does not invalidate the warranty.

However, Ingersoll-Rand Company is not liable for parts which are not genuine INGERSOLL-RAND parts.

### LIMITATIONS AND RESPONSIBILITIES

These warranties are subject to the following:

### INGERSOLL-RAND COMPANY RESPONSIBILITIES

During the emission warranty period, if a defect in material or workmanship of a warranted part or component is found, Ingersoll-Rand Company will provide:

- New, Remanufactured, or repaired parts and/or components required to correct the defect.

**Note:** Items replaced under this warranty become the property of Ingersoll-Rand Company

- Labor, during normal working hours, required to make the warranty repair. This includes diagnosis and labor to remove and install the engine, if necessary.

### OWNER RESPONSIBILITIES

During the emission warranty period, the owner is responsible for:

- The performance of all required maintenance. A warranty claim will not be denied because the scheduled maintenance was not performed. However, if the lack of required maintenance was the reason for the repair, then the claim will be denied.
- Premium of overtime labor costs.
- Costs to investigate complaints which are not caused by a defect in Ingersoll-Rand Company material or workmanship.
- Providing timely notice of a warrantable failure and promptly making the product available for repair.

---

## LIMITATIONS

Ingersoll-Rand Company is not responsible for resultant damages to an emission related part or component resulting from:

- Any application or installation Ingersoll-Rand Company deems improper as explained in the Instruction Manual.
- Attachments, accessory items, or parts not authorized for use by Ingersoll-Rand Company
- Improper off-road engine maintenance, repair, or abuse.
- Owner's unreasonable delay in making the product available after being notified of a potential product problem.

This warranty is in addition to Ingersoll-Rand Company standard warranty, applicable to the off-road engine product involved.

Remedies under this warranty are limited to the provision of material and services as specified herein. Ingersoll-Rand Company is not responsible for incidental or consequential damages such as downtime or loss-use of engine powered equipment.

## CALIFORNIA EMISSION CONTROL WARRANTY STATEMENT

### YOUR WARRANTY RIGHTS AND OBLIGATIONS

The California Air Resources Board (CARB) and Ingersoll-Rand Company are pleased to explain the emission control system warranty on your 1996 and later certified heavy duty off-road engine. In California, new heavy-duty off-road engines must be designed, built and equipped to meet the state's stringent anti-smog standards. Ingersoll-Rand Company must warrant the emission control system on your engine for the periods of time listed below provided there has been no abuse, neglect, or improper maintenance of your engine.

Your emission control system may include parts such as the fuel injection system, air induction system. Also included may be hoses, belts, connectors and other emission-related assemblies.

Where a warrantable condition exists, an authorized INGERSOLL-RAND Dealer will repair the heavy-duty off-road engine at no cost to the owner including diagnosis, parts and labor.

### MANUFACTURER'S WARRANTY COVERAGE:

The 1996 and later heavy-duty off-road engines are warranted for a period of five (5) years, or 3000 hours of operation which ever occurs first. If any emission-related part on your engine is defective, the part will be repaired or replaced by an authorized INGERSOLL-RAND Dealer.

### OWNER'S WARRANTY RESPONSIBILITIES:

- As the heavy-duty off-road engine owner, you are responsible for the performance of the required maintenance listed in owner's manual (Instruction Manual). Ingersoll-Rand Company recommends that you retain all receipts and records covering the maintenance on your engine, but Ingersoll-Rand Company cannot deny warranty solely for the lack of receipts and records or for your failure to ensure the performance of all scheduled maintenance.
- As the heavy-duty off-road engine owner, you should however be aware that Ingersoll-Rand Company may deny you warranty coverage if your heavy-duty off-road engine, or part has failed due to abuse, neglect, improper maintenance, or unapproved modifications.
- Your engine is designed to operate on commercial diesel fuel only. Use of any other fuel may result in our engine no longer operation in compliance with California's emission requirements.
- You are responsible for initiating the warranty process. The CARB suggests that you present your heavy-duty off-road engine to an authorized INGERSOLL-RAND Dealer as soon as a problem exists. The warranty repairs should be completed by the dealer as expeditiously as possible.

If you have any questions regarding your warranty rights and responsibilities, you should contact Ingersoll-Rand Company, at P.O. Box 868, Mocksville, NC 27028 or the State of California Air Resources Board, Mobile source Operation Division, P.O. Box 8001, at El Monte, CA 91731-2990.

---

## **MAINTENANCE RECOMMENDATION:**

Some Ingersoll-Rand Company non-road engines are certified by the United States Environmental Protection Agency and California Air Resource Board to comply with smoke and gaseous emission standards prescribed by Federal laws at the time of manufacture.

The engine is certified if it has a special certification label. An INGERSOLL-RAND Dealer can also inform you if the engine is certified.

Efficiency of emission control and engine performance depends on adherence to proper operation and maintenance recommendations and use of recommended fuels and lubrication oils. It is recommended that major adjustments and repair be made by your authorized INGERSOLL-RAND Dealer.

Various chemical fuel additives, which claim to reduce visible smoke, are available commercially. Although additives have been used by individuals to solve some isolated smoke problems in the field, they are not recommended for general use.

Federal smoke regulations require that engines be certified without smoke depressants.

The corrective steps taken immediately on discovery of worn parts, which may affect emission levels, will help assure proper operation of emission control systems. The use of genuine INGERSOLL-RAND parts is recommended. Suppliers of non-INGERSOLL-RAND parts must assure the owner that the use of such parts will not adversely affect emission levels.

Regular maintenance intervals, along with special emphasis on the following items, are necessary to keep exhaust emissions within acceptable limits for the useful life of the engine. Refer to the Maintenance Section of this manual. If the engine is operating under severe conditions, adjust the maintenance schedule accordingly. See your authorized INGERSOLL-RAND Dealer to help analyze your specific application, operating environment and maintenance schedule adjustments.

The following is an explanation of maintenance for emission-related components.

See the Maintenance Schedule for the specific interval for the following items.

**FUEL INJECTION PUMPS OR NOZZLES** – Fuel injection pumps or nozzles are subject to tip wear as a result to fuel contamination. This damage can cause an increase in fuel consumption, the engine to emit black smoke, misfire or run rough. Inspect, test and replace if necessary. Fuel injection pumps can be tested by an authorized INGERSOLL-RAND Dealer.

**TURBOCHARGER** – Check for any unusual sound or vibration in the turbocharger. Inspect inlet and exhaust piping and connections. Check bearing condition and perform maintenance as described in the Maintenance Schedule.

Slow engine response and low power may indicate a need for adjustment or repair. Your INGERSOLL-RAND Dealer is equipped with the necessary tools, personnel, and procedures to perform this service.

Owner is encouraged to keep adequate maintenance records, but the absence of such, in and of itself, will not invalidate the warranty.

The machine or equipment owner may perform routine maintenance, repairs and other non-warranty work or have it done at any repair facility. Such non-warranty work need not be performed at a designated warranty station in order for the warranty to remain in force.

## **CUSTOMER ASSISTANCE – EMISSION CONTROL SYSTEM WARRANTY:**

Ingersoll-Rand Company aims to ensure that the Emission Control Systems Warranty is properly administered. In the event that you do not receive the warranty service to which you believe you are entitled under the Emission Control Systems Warranty, call or write:

Ingersoll-Rand Company  
P.O. Box 868  
Mocksville, NC 27028

Tel.: 336-751-3561

Authorized Dealers are recommended for major maintenance and repair work as they are staffed with trained personnel, proper tools and are aware of the latest maintenance methods and procedures. Owners and others who desire to perform their own work should purchase a Service Manual and obtain current service information from their INGERSOLL-RAND Dealer.



---

# SECTION 3 - NOISE EMISSION

**This section pertains only to machines distributed within the United States.**

**WARNING**

## **TAMPERING WITH NOISE CONTROL SYSTEM PROHIBITED**

Federal law prohibits the following acts or the causing thereof:

(1) The removal or rendering inoperative by any persons, other than for purposes of maintenance, repair, or replacement, of any device or element of design incorporated into any new compressor for the purpose of noise control prior to its sale or delivery to the ultimate purchaser or while it is in use; or (2) the use of the compressor after such device or element of design has been removed or rendered inoperative by any person.

Among those acts included in the prohibition against tampering are these:

4. Removal or rendering inoperative any of the following:
  - a. the engine exhaust system or parts thereof
  - b. the air intake system or parts thereof
  - c. enclosure or parts thereof
5. Removal of any of the following:
  - a. fan shroud
  - b. vibration mounts
  - c. sound absorption material
6. Operation of the compressor with any of the enclosure doors open.

## **Compressor Noise Emission Control Information**

A. The removal or rendering inoperative, other than for the purpose of maintenance, repair, or replacement of any noise control device or element of design incorporated into this compressor in compliance with the noise control act;

B. The use of this compressor after such device or element of design has been removed or rendered inoperative.

**Note: the above information applies only to units that are built in compliance with the U.S. Environmental Protection Agency.**

Ingersoll-Rand Company reserves the right to make changes or add improvements without notice and without incurring any obligation to make such changes or add such improvements to products sold previously.

The Purchaser is urged to include the above provisions in any agreement for any resale of this compressor.

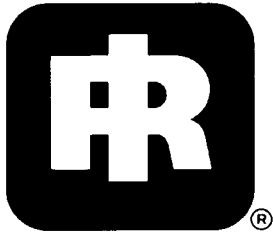

# NOISE EMISSION CONTROL MAINTENANCE LOG

<b>COMPRESSOR MODEL</b> _____
<b>SERIAL NO.</b> _____
<b>USER UNIT NO.</b> _____

<b>UNIT IDENTIFICATION</b> Engine Make & Model: _____ Serial No.: _____ Purchaser or Owner: _____ Address: _____	<b>DEALER OR DISTRIBUTOR FROM WHOM PURCHASED:</b> _____ _____ Date Purchased: _____
--	--

The Noise Control Act of 1972 (86 Stat. 1234) prohibits tampering with the noise control system of any compressor manufactured and sold under the above regulations, specifically the following acts or the causing thereof:

(1) the removal or rendering inoperative by any persons, other than for purposes of maintenance, repair, or replacement, of any device or element of design incorporated into new compressor for the purpose of noise control prior to its sale or delivery to the ultimate purchaser or while it is in use; or (2) the use of the compressor after such device or element of design has been removed or rendered inoperative by any person.

## NOISE EMISSION WARRANTY

The manufacturer warrants to the ultimate purchaser and each subsequent purchaser that this air compressor was designed, built and equipped to conform at the time of sale to the first retail purchaser, with all applicable U.S. EPA Noise Control Regulations.

This warranty is not limited to any particular part, component, or system of the air compressor. Defects in the design, assembly or in any part, component, or system of the compressor which, at the time of sale to the first retail purchaser, caused noise emissions to exceed Federal Standards are covered by this warranty for the life of the air compressor.

## INTRODUCTION

The unit for which this Maintenance Log is provided conforms to U.S. E.P.A. Regulations for Noise Emissions, applicable to Portable Air Compressors.

The purpose of this book is to provide (1) the Maintenance Performance Schedule for all required noise emission controls and (2) space so that the purchaser or owner can record what maintenance was done, by whom, where and when. The Maintenance Schedule and detailed instructions on the maintenance items are given on following page.

## MAINTENANCE SCHEDULE

ITEM	AREA	PERIOD
A.	Compressed Air Leaks	As Detected
B.	Safety and Control Systems	As Detected
C.	Acoustic Materials	Daily
D.	Fasteners	100 hours
E.	Enclosure Panels	100 hours
F.	Air Intake & Engine Exhaust	100 hours
G.	Cooling Systems	250 hours
H.	Isolation Mounts	250 hours
I.	Engine Operation	See Operator's Manual
J.	Fuels & Lubricants	See Operator's Manual

### A. Compressed Air Leaks

Correct all compressed air leaks during the first shut-down period after discovery. If severe enough to cause serious noise problems and efficiency loss, shut down immediately and correct the leak(s).

### B. Safety and Control Systems

Repair or replace all safety and control systems or circuits as malfunction occurs. No compressor should be operated with either system bypassed, disabled, or nonfunctional.

### C. Acoustic Materials

In daily inspections, observe these materials. Maintain all acoustic material as nearly as possible in its original condition. Repair or replace all sections that have: 1) sustained damage, 2) have partially separated from panels to which they were attached, 3) are missing, or have otherwise deteriorated due to severe operating or storage conditions.

### D. Fasteners

All fasteners such as hinges, nuts, bolts, clamps, screws, rivets, and latches should be inspected for looseness after each 100 hours of operation. They should be retightened, repaired, or if missing, replaced immediately to prevent subsequent damage and noise emission increase.

### E. Enclosure Panels

Enclosure panels should also be inspected at 100 hour operational intervals. All panels that are warped, punctured, torn, or otherwise deformed, such that their noise containment function is reduced, should be repaired or replaced before the next operation interval. Doors, access panels, and hatch closures especially, should be checked and adjusted at this time to insure continuous seating between gasket or acoustic material and the mating frame.

### F. Air Intake and Engine Exhaust

Engine and compressor air intake and engine exhaust systems should be inspected after each 100 hours of operation for loose, damaged, or deteriorated components. Repairs or replacements should be made before the next period of use.

### G. Cooling Systems

All components of the cooling system for engine water and compressor oil should be inspected every 250 hours of use. Any discrepancies found should be corrected before placing the unit back in operation. Unrestricted airflow over the radiator and oil cooler must be maintained at all times during operation.

### H. Isolation Mounts

Engine/airend isolation mounts should be inspected after each 250 hours of operation. Those mounts with cracks or splits in the molded rubber, or with bent or broken bolts due to operation or storage in severe environments, all should be replaced with equivalent parts.

### I. Engine Operation

Inspect and maintain engine condition and operation as recommended in the manuals supplied by the engine manufacturer.

### J. Fuels and Lubricants

Use only the types and grades of fuels and lubricants recommended in the Ingersoll-Rand Company and Engine Manufacturer's Operator and Maintenance Manuals.

---

**MAINTENANCE RECORD FOR NOISE EMISSION CONTROL AND EXTENDED WARRANTY**

ITEM NO.	DESCRIPTION OF WORK	HOURMETER READING	MAINT/ INSPECT DATE	LOCATION CITY/ STATE	WORK DONE BY (NAME)

---

# SECTION 4 - GENERAL DATA

## UNIT MODEL ..... P185WIR ..... XP185WIR

Air Delivery - cfm (litres/sec) .....	185 (87) .....	185 (87)
Engine Speed - RPM (Full Load) .....	2500 .....	2500
- RPM (No Load) .....	1700 .....	1700

### COMPRESSOR

Rated Operating Pressure - psi (kPa) .....	100 (689) .....	125 (861)
Safety Valve Setting - psi (kPa) .....	150 (1034) .....	150 (1034)
Net Weight (less fuel) pounds .....	2130 .....	2130

### ENGINE (Diesel)

Manufacturer .....	Ingersoll-Rand	
Model .....	4IR18N .....	4IR18T
Electrical System .....	12 VDC .....	12 VDC

### FLUID CAPACITIES (P/XP185WIR)

Compressor Lubricant .....	12 quarts (11.4 litres)
Engine Lube .....	10.8 quarts ( 10.2 litres)
Fuel Tank .....	27 U.S. gal. (103 litres)

### UNITS MEASUREMENTS/WEIGHTS (P/XP185WIR)

Overall Length .....	11.5 feet (3.5 meters)
Overall Height .....	4.8 feet (1.46 meters)
Overall Width .....	5.7 feet (1.74 meters)
Track Width .....	4.9 feet (1.49 meters)

### RUNNING GEAR (P/XP185WIR)

Tire Size .....	ST205/75D15
Inflation Pressure (Cold) .....	35 psi
Towing Speed (Maximum) .....	65 mph (105 km/hr)

**CAUTION: Any departure from the specifications may make this equipment unsafe.**

### EXPENDABLE SERVICE PARTS (P/XP185WIR)

Compressor Oil Filter Element .....	36897353
Compressor Oil Separator Element .....	54625942
Air Cleaner Element (compressor) .....	35393685
Air Cleaner Element (engine) .....	35393685
Engine Oil Filter Element .....	22226351
Engine Fuel Filter Element .....	22226369
Fuel Water Separator Element .....	54525530

---

# SECTION 5 - OPERATION

## BEFORE TOWING

### **WARNING**

**Failure to follow these instructions CAN cause severe injury or death.**

- Assure tow vehicle has towing capacity for weight of this unit as stated on general data decal.
- Position the tow vehicle to align its hitch with the pintle eye or coupler of the compressor.
- Engage the parking brake and chock the tires of the tow vehicle.
- Stand to the side and ensure pin is FULLY inserted (secure) in tube of jack. Crank jack to seat pintle eye or coupler onto hitch. Latch and lock hitch. Cross safety chain(s) under drawbar. Attach to vehicle.
- Crank jack to raise pad off the ground. Pull pin from tube of jack. Fold jack handle down and forward. Swing up jack tube and FULLY insert pin in tube.
  - Remove tire chocks.
  - Test brakes, if so equipped.
  - Test lights (running, stop, and turn signals).

### **WARNING**

**Always raise (or remove) jack for maximum ground clearance before towing.**

## SETTING - UP (ALL UNITS)

- Place the unit in an open, well-ventilated area. Position as level as possible. The design of these units permits a 15 degree sidewise limit on out-of-level operation.
- When the unit is to be operated out-of-level, it is important: (1) to keep the engine crankcase oil level near the high level mark (with the unit level), and (2) to have the compressor oil level gauge show no more than mid-scale (with the unit running at full load). Do not overfill either the engine crankcase or the compressor lubricating oil system.

## TOWING

### **WARNING**

**Failure to follow these instructions CAN cause severe injury or death.**

- Ensure that tires, wheels and running gear are in good condition and secure.
- Ensure that tires are inflated to 35 psi.
- Do not tow this unit in excess of 50 mph (80 km/hr).
- Use a tow vehicle whose towing capacity is greater than the gross weight of this unit.

## DISCONNECT

- Engage tow vehicle parking brake.
- Chock tires of compressor.
- Set the vehicle parking brake. Chock wheels of unit.
- Standing to the side, remove pin from tube of jack.
- Disconnect safety chains. Crank jack to raise eye or coupler from hitch. Tow vehicle can be moved.

---

### COMPRESSOR OIL LEVEL

Check the compressor oil level in the sight glass located on the separator tank.

**WARNING**

**NO SMOKING, SPARKS or OPEN FLAME near fuel.**

**WARNING**

**Always raise (or remove) jack for maximum ground clearance before towing.**

### UTILITY PACKAGE SET-UP

**(no running gear)**

This unit must be located on vehicle bed to allow access for normal servicing and maintenance.

The air going into the inlet grille must be relatively free of oil, dirt, soot and other debris. It must be no more than 10 degrees F. (5 degrees C) over the ambient temperature.

### WATER COOLED ENGINE

**CAUTION**

**Do not remove pressure cap from a HOT radiator. Allow radiator to cool down before removing pressure cap. Use extreme care when removing a pressure cap from a liquid cooling system for the engine. The sudden release of pressure from a heated cooling system can result in a loss of coolant and possible severe personal injury.**

## CONTROL PANEL

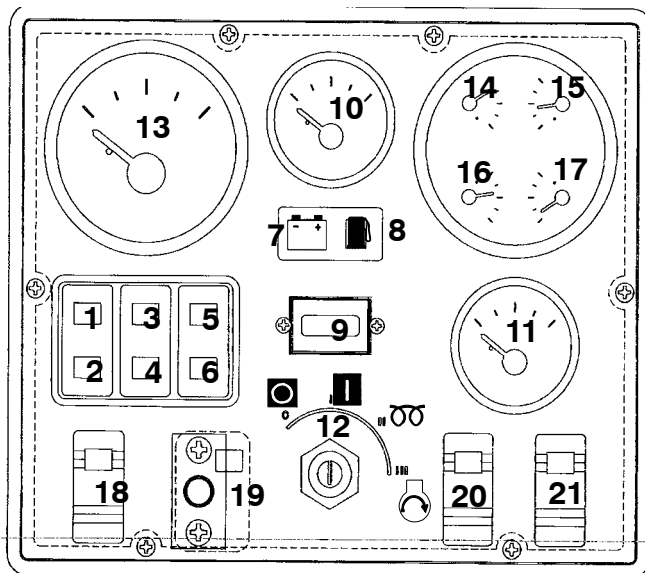

### Diagnostic/Auto Shutdown (Optional)

- 1. High Engine Temperature -**  
Coolant above 220°F (104°C) or more.
- 2. Low Engine Oil Pressure -** 12 psi or less
- 3. High Compressor Temperature -**  
248°F (120°C)
- 4. Air Filters Restricted -** Needs Servicing.
- 5.** Spare
- 6.** Spare

### Diagnostic/Auto Shutdown (Standard)

- 7. Alternator Not Charging -** needs attention.
- 8. Low Fuel Level -** Must add fuel to operate.
- 9. Hourmeter -** Records running time for maintenance.
- 10. Compressor Discharge Pressure Gauge -**  
Indicates pressure in receiver tank, psi (kPa).
- 11. Fuel Level Gauge -** Indicates amount of fuel in tank.

### Controls (Standard)

#### **12. Power Switch -**

Rotate "ON" to activate systems prior to Starting. Rotate "Off" to stop engine.

#### **19. Service Air Button -** After warm-up, PUSH.

Provides full air pressure at the service outlet.

### Optional Controls

#### **13. Engine Speed Gauge -**

Indicates engine speed.

#### **14. Discharge Air Temp. Gauge -**

Indicates in °F and °C. Normal operating range: 185°F/85° to 248°F/120°C.

#### **15. Engine Oil Pressure Gauge -**

Indicates engine oil pressure (psi (kPa)).

#### **16. Engine Water Temp. Gauge -**

Indicates coolant temperature, with normal operating range from 180°F (82°C) to 210°F (99°C).

#### **17. Voltmeter -** Indicates battery condition.

#### **18. Ether Inject Button -** Injects a measured shot. USE SPARINGLY. (Not on WIR Models).

#### **20. Spare**

#### **21. Spare**



---

## **BEFORE STARTING**

### **CAUTION**

Whenever the machine is stopped, air will flow back into the compressor system from devices or systems downstream of the machine unless the service valve is closed. Install a check valve at the machine service valve to prevent reverse flow in the event of an unexpected shutdown when the service valve is open.

### **WARNING**

Unrestricted air flow from a hose will result in a whipping motion of the hose which can cause severe injury or death. A safety device must be attached to the hose at the source of supply to reduce pressure in case of hose failure or other sudden pressure release. Reference: OSHA regulation 29 CFR Section 1926.302 (b).

#### **Before Starting:**

- Open service valve (s) to ensure pressure is relieved in receiver-separator system. Close valve (s) in order to build up full air pressure and ensure proper oil circulation.
- Check battery for proper connections and condition.
- Check the engine oil level. Maintain per marks on dipstick.
- Check the fuel level. Add only CLEAN DIESEL fuel for maximum service from the engine.
- Check the compressor lubricating oil level in the sight glass located on the separator tank.

### **WARNING**

This machine produces loud noise with doors open. Extended exposure to loud noise can cause hearing loss. Wear hearing protection when doors or valve (s) are open.

- Close the side doors to maintain a cooling air path and to avoid recirculation of hot air. This will maximize the life of the engine and compressor and protect the hearing of surrounding personnel.
- Be sure no one is IN or ON the compressor unit.

### **CAUTION**

Exercise extreme caution when using a booster battery to start. To jump start: Connect the ends of one booster cable to the positive (+) terminals of each battery. Then connect one end of the other cable to the negative (-) terminal of the booster battery and the other end to the engine block. **NOT TO THE NEGATIVE (-) TERMINAL OF THE WEAK BATTERY.**

#### **After Starting:**

- a. Reduce engine speed to IDLE.
- b. Disconnect the negative (-) cable from the engine block first, then from the booster battery.
- c. Disconnect positive (+) cable from both batteries.

#### **STARTING**

1. Turn the POWER switch to "ON".
2. Turn power switch to "START" position to crank engine.

**Note:** Do not operate the starter motor for more than 10 seconds without allowing at least 30 seconds cooling time between start attempts.

#### **Cold Weather Starting:**

Intake Heaters. Leave "ON" 15 seconds before starting.

Open manual blowdown valve and service valve, if nothing is connected until engine is running.

### **CAUTION**

Engine is equipped with glow plugs for cold starting aid.

Do not use Ether/starting fluid. Engine damage can occur.

3. Release POWER SWITCH when the engine starts and sustains running.
4. Allow engine to warm up 5 to 10 minutes
5. If so equipped, press Service Air Button. Open air service valve(s).

---

## **UNITS WITH OPTIONAL DIAGNOSTICS LAMPS**

### **NOTICE**

None of the panel lamps should be glowing when machine is operating. If they are, shut unit down and refer to Trouble Shooting Section.

### **STOPPING**

1. Close air service valve.
2. Allow the unit to run at idle for 3 to 5 minutes to reduce the engine temperatures.
3. Turn Power Switch to "OFF" position.
4. When the engine stops, automatic blowdown valve should relieve system air pressure. If automatic blowdown valve malfunction is suspected, open manual blowdown valve.
5. Never allow unit to sit under pressure when engine is not running.

### **WARNING**

Since the service valve is closed, air downstream of the valve may be trapped. A vent hole in the service valve will slowly bleed air from the hose. Do not disconnect hoses until all pressure has been vented.

### **NOTICE**

Do NOT wire around or bypass a shutdown sensor or switch.

All units in this family of machines are protected by sensors or switches at the following locations:

- (1) Low engine oil pressure, in the engine.
- (2) High engine coolant temperature, in the engine.

### **High Discharge AIR Temperature**

- (3) At the airend outlet.
- (4) In separator tank.

### **Units with Diagnostic Lamps:**

In a shutdown situation, the function of the panel lamps is to indicate what specific failure caused the unit to shut down. These lamps will remain illuminated until the Power Switch is turned "OFF".

## P185WIR Speed and Pressure Regulator Adjusting Instructions

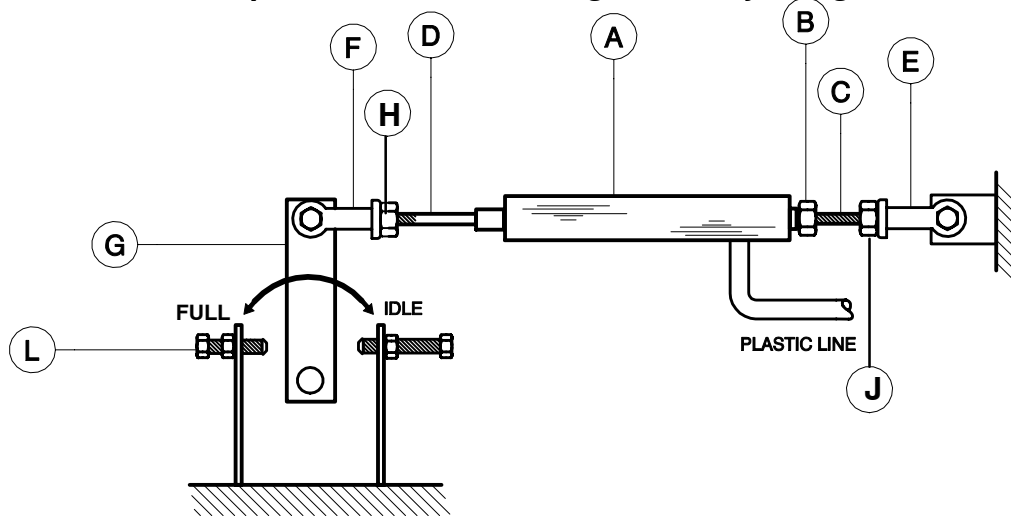

The engine idle and full speed settings are set and sealed at the factory, and should not be adjusted. Serious injury may result if the full speed is increased. Removal of the seals without authorization could affect the warranty. If speed settings are lost due to engine fuel pump service or other repairs, the speed settings can be reset as follows:

### Before Starting

1. At the Pressure Regulator (on service pipe near receiver tank), remove the cover to expose the adjusting screw. Loosen the jam nut and turn screw counterclockwise until tension is no longer felt at the screw. Then, turn screw clockwise one full turn.
2. Close service valve(s).
3. Inspect throttle arm (G) on engine governor to see the arm is resetting against FULL stop (L) on governor. Loosen jam nut on air actuating cylinder (A) and then turn cylinder rod (D) until throttle arm (G) is forced against stop (L).

### After Starting Unit

4. If equipped, push the SERVICE AIR button on the control panel, making certain the button does not pop back out. The unit should speed up and then unload (and drop back to IDLE). With the unit unloaded, turn the adjusting screw on the pressure regulator clockwise until the discharge pressure gauge indicates 125–130 psi. Tighten the pressure regulator jam nut. Replace cover.
5. With the service valve closed, adjust IDLE speed (\*). Adjust speed using adjusting rod (D). Tighten jam nut (H).
6. Open the service valve and adjust the discharge pressure to 100 psi (700 kPa). Now turn adjusting rod (C) until the proper engine FULL speed setting (\*) is reached. Tighten jam nuts (B & J)
7. To obtain maximum cfm at any pressure between 80 psi (550 kPa) and maximum pressure rating (\*), make adjustment at the pressure regulator to obtain desired discharge pressure at FULL engine speed. Lock adjusting screw and replace cover.

\* See General Data Specifications.

---

# SECTION 6 - MAINTENANCE

## CAUTION

Any unauthorized modification or failure to maintain this equipment may make it unsafe and out of factory warranty.

If performing more than visual inspections, disconnect battery cables and open manual blowdown valve.

Use extreme care to avoid contacting hot surfaces (engine exhaust manifold and piping, air receiver and air discharge piping, etc.).

Never operate this machine with any guards removed.

Inch and metric hardware was used in the design and assembly of this unit. Consult the parts manual for clarification of usage.

**Notice:** Disregard any maintenance pertaining to components not provided on your machine.

## GENERAL

In addition to periodic inspections, many of the components in these units require periodic servicing to provide maximum output and performance. Servicing may consist of pre-operation and post-operation procedures to be performed by the operating or maintenance personnel. The primary function of preventive maintenance is to prevent failure, and consequently, the need for repair. Preventive maintenance is the easiest and the least expensive type of maintenance. Maintaining your unit and keeping it clean at all times will facilitate servicing.

## SCHEDULED MAINTENANCE

The maintenance schedule is based on normal operation of the unit. This page can be reproduced and used as a checklist by the service personnel. In the event unusual environmental operating conditions exist, the schedule should be adjusted accordingly.

## COMPRESSOR OIL LEVEL

Check the compressor oil level in the sight glass located on the separator tank.

## AIR CLEANER

If this unit is equipped with the Optional Diagnostic Panel, it has an AIR FILTERS RESTRICTED lamp on the instrument panel, covering both the engine and the compressor.

This should be checked daily during operation. If the lamp glows (red) with the unit operating at full speed, servicing of the cleaner element is necessary.

Also weekly squeeze the rubber valve (precleaner dirt dump) on each air cleaner housing to ensure that they are not clogged.

The air filters restricted sensor will automatically reset after the main power switch is turned to "OFF."

---

**To service the air cleaners on all units proceed as follows:**

1. Release cover latches, and remove cover.
2. Inspect air cleaner housing for any condition that might cause a leak and correct as necessary.
3. Wipe inside of air cleaner housing with a clean, damp cloth to remove any dirt accumulation, especially in the area where the element seals against the housing.
4. Inspect element by placing a bright light inside and rotating slowly. If any holes or tears are found in the paper, discard this element. If no ruptures are found, the element can be cleaned.
5. If a new air filter element is to be used check it closely for shipping damage.
6. Install cleaned or new elements in the reverse order to the above.
7. Install cover and fasten latches.

In the event that the filter element must be reused immediately, compressed air cleaning (as follows) is recommended since the element must be thoroughly dry. Direct compressed air through the element in the direction opposite to the normal air flow through the element.

Move the nozzle up and down while rotating the element. Be sure to keep the nozzle at least one inch (25.4 mm) from the pleated paper.

**NOTE: To prevent damage to the element, never exceed a maximum air pressure of 100 psi (700 kPa).**

In the event the element is contaminated with dry dirt, oil or greasy dirt deposits, and a new element is not available, cleaning can be accomplished by washing, using the air cleaner element manufacturer's recommendations.

**NOTE:** It is recommended that replacement elements be installed in the unit. The elements just removed for cleaning can be washed and stored as future replacement elements.

In addition, the air cleaner system (housing and piping) should be inspected every month for any leakage paths or inlet obstructions. Make sure the air cleaner mounting bolts and clamps are tight. Check the air cleaner housing for dents or damage which could lead to a leak. Inspect the air transfer tubing from the air cleaner to the compressor and the engine for leaks.

Make sure that all clamps and flange joints are tight.

### **GAUGES**

The instruments or gauges are essential for safety, maximum productivity and long service life of the machine. Inspect the gauges and test any diagnostic lamps prior to start-up. During operation observe the gauges and any lamps for proper functioning. Refer to Operating Controls, for the normal readings.

### **FUEL TANK**

CLEAN fuel in the fuel tanks is vitally important and every precaution should be taken to ensure that only clean fuel is poured or pumped into the tank.

When filling the fuel tank on this unit, by methods other than a pump and hose, use a CLEAN non-metallic funnel.

### **BATTERY**

Keep the battery posts-to-cable connections clean, tight and lightly coated with a grease. Also the electrolyte level in each cell should cover the top of the plates. If necessary, top-up with clean distilled water.

### **TIRES**

A weekly inspection is recommended. Tires that have cuts or cracks or little tread should be repaired or replaced. Monthly check the wheel lug nuts for tightness.

---

## **COMPRESSOR OIL COOLER**

The compressor lubricating and cooling oil is cooled by means of the fin and tube-type oil cooler, located below the radiator. The lubricating and cooling oil, flowing internally through the core section, is cooled by the air stream from the cooling fan flowing past the core section. When grease, oil and dirt accumulate on the exterior surfaces of the oil cooler, its efficiency is impaired.

Each month it is recommended that the oil cooler be cleaned by directing compressed air which contains a nonflammable, non-caustic safety solvent through the core of the oil cooler. This should remove the accumulation of grease, oil and dirt from the exterior surfaces of the oil cooler core so that the entire cooling area can transmit the heat of the lubricating and cooling oil to the air stream.

In the event foreign deposits, such as sludge and lacquer, accumulate in the oil cooler to the extent that its cooling efficiency is impaired, a resulting high discharge air temperature is likely to occur, causing shut down of the unit. To correct this situation it will be necessary to clean it using a cleaning compound in accordance with the manufacturer's recommendations.

## **HOSES**

Each month it is recommended that all of the intake lines to and from the air cleaners, the engine cooling system hoses and all of the flexible hoses used for air, oil, and fuel be inspected.

To ensure freedom from air leaks, all rubber hose joints and the screw-type hose clamps must be absolutely tight. Regular inspection of these connections for wear or deterioration is necessary.

Premature wear of both the engine and compressor is ASSURED whenever dust-laden air is permitted to enter the engine's combustion chamber or the compressor intake.

The flexible hoses used in the fuel, oil and air lines on these units are primarily used for their ability to accommodate relative movement between components. It is important they be periodically inspected for wear and deterioration. It is also important the operator does not use the hoses as convenient hand hold or steps. Such use can cause early cover wear and hose failure.

Piping systems operating at less than 150 psi (1050 kPa) may use a special nylon tubing. The associated fittings are also of a special "push-in" design. If so, features are as follows:

Pulling on the tubing will cause the inner sleeve to withdraw and compress, thus tightening the connection. The tubing can be withdrawn only while holding the sleeve against the fitting. The tubing can be removed and replaced numerous times without losing its sealing ability.

To install the nylon tubing, make a mark (with tape or grease pencil) approximately 7/8 inch from the end of the tubing. Insert the tubing into the sleeve and "push-in" past the first resistance to the bottom. The mark should be approximately 1/16 inch from the sleeve, for the 3/8 inch O.D. tubing; 1/8 inch for the 0.25 inch O.D. tubing. This will ensure that the tubing is fully engaged in the sealing mechanism.

## **COMPRESSOR OIL FILTER**

The oil filter must be replaced every 500 hours of operation or six (6) months, whichever comes first.

To service the oil filters it will first be necessary to shut the unit down. Wipe off any external dirt and oil from the exterior of the filter to minimize any contamination from entering the lubrication system. Proceed as follows:

### **WARNING**

**High pressure air can cause severe injury or death from hot oil and flying parts. Always relieve pressure before removing caps, plugs, covers or other parts from pressurized air system.**

1. Open the service air valve(s) to ensure that system is relieved of all pressure. Close the valve(s).
2. Turn the spin-on filter element counterclockwise to remove it from the filter housing. Inspect the filter.

### **NOTICE**

If there is any indication of formation of varnishes, shellacs or lacquers on the oil filter element, it is a warning the compressor lubricating oil has improper characteristics and should be immediately changed.

3. Inspect the oil filter head to be sure the gasket was removed with the oil filter element. Clean the gasket seal area on the oil filter head.

### **NOTICE**

Installing a new oil filter element when the old gasket remains on the filter head, will cause an oil leak and can cause property damage.

4. Lubricate the new filter gasket with the same oil being used in the machine.
5. Install new filter by turning element clockwise until gasket makes initial contact. Tighten an additional 1/2 to 3/4 turn.
6. Start unit and allow to build up to rated pressure. Check for leaks before placing unit back into service.

### **FASTENERS**

Visually check entire unit in regard to bolts, nuts and screws being properly secured. Spot check several capscrews and nuts for proper torque. If any are found loose, a more thorough inspection must be made. Take corrective action.

### **COMPRESSOR OIL**

The lubricating and cooling oil must be replaced every 500 hours of operation or six (6) months, whichever comes first.

### **RUNNING GEAR**

Every month or 500 miles, tighten the wheel lug nuts to 85 - 95 lbs.-ft. Every six months the wheel bearings, grease seals and axle spindles should be inspected for damage (corrosion, etc.) or excessive wear. Replace any damaged or worn parts. Repack wheel bearings. Use a wheel bearing grease conforming to specification MIL-G-10924 and suitable for all ambient temperatures.

Grease can be replaced in a wheel bearing using a special fixture or by hand as follows.

Before installing bearing, place a light coat of grease on the bearing cups which are pressed in the hub.

Place a spoonful of grease in the palm of one hand and take the bearing in the other hand. Push a segment of the wider end of the bearing down into the outer edge of the grease pile closest to the thumb. Keep lifting and pushing the bearing down into the edge of the grease pile until grease oozes out both from the top and from between the rollers. Then rotate the bearing to repeat this operation on the next segment. Keep doing this until you have the entire bearing completely filled with grease.

Excessive grease in the hub or grease cap serves no purpose due to the fact that there is no way to force the grease into the bearing. The manufacturer's standard procedure is to thoroughly pack the inner and outer bearing with grease and then to apply only a very small amount of grease into the grease cap.

If bearing adjustment is required or the hub has been removed for any reason, the following procedure must be followed to ensure a correct bearing adjustment of 0.001 to .012 free play.

1. While rotating hub slowly to seat the bearings, tighten spindle nut to approximately 15 lbs.-ft. Grasp the tire at the top and bottom and rock, in and out. There should be no evidence of looseness (free play) at the bearing.
2. Loosen nut to remove preload torque. Do not rotate hub.
3. Finger tighten nut until just snug. Loosen nut until the first nut castellation lines up with cotter pin hole in spindle. Insert cotter pin.
4. Ensure a definite but minimal amount of free play by rocking the tire.
6. Nut should be free to move with only restraint being the cotter pin.

## **RECEIVER-SEPARATOR SYSTEMS**

### **WARNING**

**High pressure air can cause severe injury or death from hot oil and flying parts. Always relieve pressure before removing caps, plugs, covers or other parts from pressurized air system.**

- **Open service valve at end of machine.**
- **Ensure pressure is relieved, with BOTH:**
  - **Discharge air pressure gauge reads zero (0).**
  - **No air discharging from service valve.**
- When draining oil, remove plug from bottom of separator tank.
- When adding oil, remove and replace (make tight) plug on side of separator tank.

---

- In the compressor lubricating and cooling system, separation of the oil from the compressed air takes place in the receiver-separator tank. As the compressed air enters the tank, the change in velocity and direction drop out most of the oil from the air. Additional separation takes place in the oil separator element which is located in the top of the tank. Any oil accumulation in this separator element is continuously drained off by means of a scavenge tube which returns the accumulated oil to the system.

The life of the oil separator element is dependent upon the operating environment (soot, dust, etc.) and should be replaced every twelve months or 2000 hours. To replace the element proceed as follows:

- Ensure the tank pressure is zero.
- Disconnect the hose from the scavenge tube.
- Remove scavenge tube from tank cover.
- Disconnect service line from cover.
- Remove cover mounting screws.
- Remove cover and element.
- Remove any gasket material left on cover or tank.
- Install new element.

## **SCAVENGE LINE**

The scavenge line runs from the combined orifice/drop tube in the separator tank, to the orifice fitting located in the airend.

Examine the orifice, check valve and hoses at every service or in the event of oil carryover into the discharge air.

It is good preventative maintenance to check that the scavenge line and tube are clear of any obstruction each time the compressor lubricant is changed as any blockage will result in oil carryover into the discharge air.



---

-

## **SCAVENGE LINE**

### **WARNING**

High pressure air can cause severe injury or death from hot oil and flying parts. Always relieve pressure before removing caps, plugs, covers or other parts from pressurized air system.

The scavenge line originates at the receiver-separator tank cover and terminates at the compressor air-end near the oil filter element. An orifice check valve is located on the scavenge tube.

Once a year or every 1000 hours of operation, whichever comes first, replace the separator element and clean the scavenge orifice/check valve.

Excessive oil carry-over may be caused by an oil-logged separator element. Do not replace element without first performing the following maintenance procedure:

1. Check oil level. Maintain as indicated earlier in this section.
2. Thoroughly clean scavenge line, any orifice and check valve.
3. Assure minimum pressure valve/orifice is operational.
4. Run unit at rated operating pressure for 30 to 40 minutes to permit element to clear itself.

## **EXTERIOR FINISH CARE**

This unit was painted and heat cured at the factory with a high quality, thermoset polyester powder coating. The following care will ensure the longest possible life from this finish.

1. If necessary to remove dust, pollen, etc. from housing, wash with water and soap or dish washing liquid detergent. Do not scrub with a rough cloth, pad, etc.
2. If grease removal is needed, a fast evaporating alcohol or chlorinated solvent can be used. Note: This may cause some dulling of the paint finish.

3. If the paint has faded or chalked, the use of a commercial grade, non-abrasive car wax may partially restore the color and gloss.

## **Field Repair of Texture Paint**

1. The sheet metal should be washed and clean of foreign material and then thoroughly dried.
2. Clean and remove all grease and wax from the area to be painted using Duponts 3900S Cleaner prior to sanding.
3. Use 320 grit sanding paper to repair any scratches or defects necessary.
4. Scuff sand the entire area to be painted with a red scotch brite pad.
5. Wipe the area clean using Duponts 3900S.
6. Blow and tack the area to be painted.
7. Apply a smooth coat of Duponts 1854S Tuffcoat Primer to all bare metal areas and allow to dry.
8. Apply 2 medium - wet coats of Duponts 222S Adhesion Promoter over the entire area to be painted, with a 5 minute flash in between coats.
9. To apply the texture coat, use Duponts 1854S Tuffcoat Primer. The proper technique to do this is to spray the Tuffcoat Primer using a pressure pot and use about 2-5 pounds of air pressure. This will allow the primer to splatter causing the textured look. Note: you must be careful not to put too much primer on at one time, this will effect the amount of texture that you are trying to achieve. Allow the texture coat to flash for 20 minutes or until dry to touch.
10. Apply any of Duponts Topcoat Finishes such as Imron™ or Centari™ according to the label instructions.

Note: To re-top coat the textured surfaces when sheet metal repairs are not necessary, follow steps 1, 2, 4, 5, 6, 8 and 10.

# MAINTENANCE SCHEDULE

These time periods should be reduced if operating in extreme conditions (very hot, cold, dusty or wet).

	Daily	Weekly	Monthly	3 MOS .	6 MOS.	12 MOS.
<b>SMALL UNITS (P100-P600)</b>				250 hours	500 hours	1000 hours
<b>LARGE UNITS (HP600-P1600)</b>				500 hours	1000 hours	2000 hours
**Hydraulic Oil Level		C			R	
Compressor Oil Level	C					
Engine Oil Level	C					
**Radiator Coolant Level	C					
Gauges/Lamps	C					
Air Cleaner Service Indicators	C					
Fuel Tank (fill at end of day)	C				DRAIN	
**Fuel/Water Separator	DRAIN C					
Air Cleaner Precleaner Dumps		C				
Fan/Alternator Belts		C				
Battery Connections/Electrolyte		C				
**Tire Pressure and Surface		C				
**Wheel Lug Nuts			C			
Hoses (oil, air, intake, etc.)			C			
Automatic Shutdown System	Test		C			
Air Cleaner System	Visual		C			
Compressor Oil Cooler	Exterior		C	CLEAN		
**Engine Radiator	Exterior		C	CLEAN		
Fasteners, Guards				C		
Air Cleaner Elements				WI		
** Fuel/Water Separator Element					R	
*Compressor Oil Filter Element				B	A	
*Compressor Oil					R	
**Wheels (bearings, seals, etc)					C	C
Engine Coolant	Test				C	R
Shutdown Switch Settings	Test					C
Scavenge Orifice & related parts						CLEAN
Oil Separator Element						R
**Lights (running, brake, & turn)	CBT					
**Pintle Eye Bolts	CBT					
Engine (oil changes, oil & fuel filters, etc)				R		

\*\*Disregard if not appropriate for this particular machine.

\*NXP Units - consult manual

R=replace, C=check (adjust if necessary), WI=OR when indicated, CBT = check before towing.

A = Small Units

B = Large Units

Refer to specific sections of the operator's manual for more information.

## SECTION 7 - Portable Compressor Fluid Chart

Refer to these charts for correct compressor fluid required. Note that the selection of fluid is dependent on the design operating pressure of the machine and the ambient temperature expected to be encountered before the next oil change.

**Note: Fluids listed as “preferred” are required for extended warranty.**

**Compressor oil carryover (oil consumption) may be greater with the use of alternative fluids.**

Design Operating Pressure	Ambient Temperature	Specification
100 psi to 300 psi	-10°F to 125°F (-23°C to 52°C)	Preferred: <b>IR Pro-Tec™</b>  Alternate: ISO Viscosity Grade 46 with rust and oxidation inhibitors, designed for air compressor service.
350 psi	(-23°C to 52°C) -10°F to 125°F  65°F to 125°F (-18°C to 52°C)	Preferred: <b>IR XHP 605</b>  Alternate: IR XHP405  ISO Viscosity Grade 68 Group 3 or 5 with rust and oxidation inhibitors designed for air compressor service.  Preferred: <b>XHP605</b> <b>IR XHP1001</b>

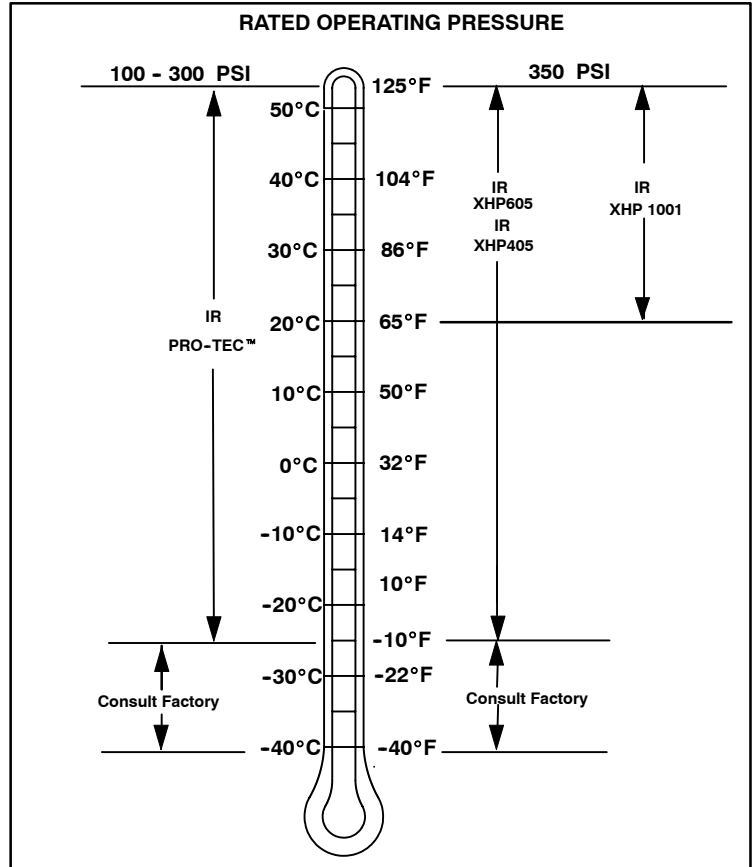

Preferred Ingersoll-Rand Fluids - Use of these fluids with original I-R filters can extend airtend warranty. Refer to operator's manual warranty section for details or contact your I-R representative.

Ingersoll-Rand Preferred Fluids	1 gal. (3.8 Litre)	5 gal. (19.0 Litre)	55 gal. (208.2 Litre)	220 gal. (836 litre)
<b>Preferred:</b>				
IR Pro-Tec™	36899698	36899706	36899714	36899722
IR XHP605	-	22252076	22252050	22252068
IR XHP1001	-	35612738	35300516	-
XHP405	-	22252126	22252100	22252118
Engine Oil	54480918	36875938	36866903	

---

# Section 8 - Trouble Shooting

## INTRODUCTION

Trouble shooting for a portable air compressor is an organized study of a particular problem or series of problems and a planned method of procedure for investigation and correction. The trouble shooting chart that follows includes some of the problems that an operator may encounter during the operation of a portable compressor.

The chart does not attempt to list all of the troubles that may occur, nor does it attempt to give all of the answers for correction of the problems. The chart does give those problems that are most apt to occur. To use the trouble shooting chart:

- A. Find the “complaint” depicted as a bold heading.
- B. Follow down that column to find the potential cause or causes. The causes are listed in order to suggest an order to follow in trouble shooting.

## ACTION PLAN

### **A. Think Before Acting**

Study the problem thoroughly and ask yourself these questions:

- (1) What were the warning signals that preceded the trouble?
- (2) Has a similar trouble occurred before?
- (3) What previous maintenance work has been done?
- (4) If the compressor will still operate, is it safe to continue operating it to make further checks?

### **B. Do The Simplest Things First**

Most troubles are simple and easily corrected. For example, most complaints are “low capacity” which may be caused by too low an engine speed or “compressor over- heats” which may be caused by low oil level.

Always check the easiest and most obvious things first; following this simple rule will save time and trouble.

**Note:** For trouble shooting electrical problems, refer to the Wiring Diagram Schematic.

### **C. Double Check Before Disassembly**

The source of most compressor troubles can be traced not to one component alone, but to the relationship of one component with another. Too often, a compressor can be partially disassembled in search of the cause of a certain trouble and all evidence is destroyed during disassembly. Check again to be sure an easy solution to the problem has not been overlooked.

### **D. Find And Correct Basic Cause**

After a mechanical failure has been corrected, be sure to locate and correct the cause of the trouble so the same failure will not be repeated. A complaint of “premature breakdown” may be corrected by repairing any improper wiring connections, but something caused the defective wiring. The cause may be excessive vibration.

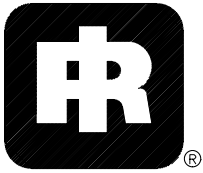

# TROUBLE SHOOTING CHART

**Bold Headings depict the COMPLAINT - Subheadings depict the CAUSE**

Note: Subheadings suggest order to follow in cause of troubleshooting.

## **Short Air Cleaner Life:**

Dirty Operating Conditions  
Inadequate Element Cleaning  
Defective Service Indicator  
Incorrect Stopping Procedure  
Wrong Air Filter Element

## **Excessive Oil In Air:**

High Oil Level  
Out of Level > 15 degrees  
Clogged Scavenge Orifice  
Scavenge Tube Blocked  
Defective Scavenge Check Valve  
Sep. Tank Blown Down Too Quickly  
Defective Minimum Pressure Valve  
Defective Separator Element

## **Will Not Unload:**

Leaks in Regulator Piping  
Incorrect Pressure Regulator Adjustment  
Malfunctioning Pressure Regulator  
Malfunctioning Inlet Unloader/Butterfly Valve  
Ice in Regulation Lines/Orifice

## **Oil In Air Cleaner:**

Incorrect Stopping Procedure

## **Safety Valve Relieves:**

Leaks In Regulator Piping  
Incorrect Pressure Regulator Adjustment  
Malfunctioning Pressure Regulator  
Malfunctioning Inlet Unloader/Butterfly Valve  
Defective Separator Element  
Ice in Regulation Lines/Orifice  
Defective Safety Valve

## **Excessive Compressor Oil Temperature:**

Ambient Temperature Too High  
Out of Level > 15 degrees  
Low Oil Level  
Dirty Cooler  
Dirty Operating Conditions  
Loose or Broken Belts  
Operating Pressure Too High  
Malfunctioning Thermostat  
Defective Minimum Pressure Valve  
Blocked or Restricted Oil Lines  
Airend Malfunctioning

## **Engine RPM Low:**

Clogged Fuel Filter  
Operating Pressure Too High  
Incorrect Pressure Regulator Adjustment  
Dirty Air Filter  
Malfunctioning Speed Control Cylinder  
Defective Separator Element  
Ice In Regulation Lines/Orifice  
Engine Malfunctioning  
Airend Malfunctioning

## **Excessive Vibration:**

Low Engine RPM  
Rubber Mounts Damaged  
Out of Balance Fan  
Engine Malfunctioning  
Airend Malfunctioning

## **Low CFM:**

Low Engine RPM  
Dirty Air Filter  
Incorrect Linkage Adjustment  
Incorrect Pressure Regulator Adjustment  
Malfunctioning Inlet Unloader/Butterfly Valve  
Malfunctioning Speed Control Cylinder  
Defective Minimum Pressure Valve  
Defective Separator Element

---

**Unit Shutdown:**

Out of Fuel  
Compressor Oil Temp. Too High  
Engine Oil Pressure Too Low  
Broken Engine Fan Belt  
Loose Wire Connection  
Defective Switches  
Defective Shutdown Solenoid  
Malfunctioning Relay  
Blown Fuse  
Engine Malfunctioning  
Airend Malfunctioning

**Won't Start/Run:**

Low Battery Voltage  
Blown Fuse  
Malfunctioning Start Switch  
Clogged Fuel Filters  
Out of Fuel  
Compressor Oil Temp. Too High  
Engine Water Temp. Too High  
Engine Oil Pressure Too Low  
Loose Wire Connection  
Defective Switches  
Malfunctioning Relay  
Engine Malfunctioning  
Airend Malfunctioning

**Unit Fails To Shutdown:**

Defective Switches  
Defective Shutdown Solenoid  
Malfunctioning Relay  
Defective Start Switch

**Engine Temperature Lamps Stays On:**

Broken Engine Fan Belt  
Malfunctioning Circuit Board  
Defective Engine Belt Break Switch  
Ambient Temperature Too High  
Dirty Operating Conditions  
Dirty Cooler  
Out of Level >15 degrees  
Operating Pressure Too High

**Alternator Lamp Stays On:**

Loose or Broken Belts  
Loose Wire Connection  
Defective Battery  
Malfunctioning Alternator  
Malfunctioning Circuit Board

**Engine Oil Pressure Lamp Stays On:**

Low Oil Level  
Out of Level >15 degrees  
Wrong Lube Oil  
Engine Malfunctioning

**Alternator Lamp Stays Off:**

Loose Wire Connection  
Malfunctioning Circuit Board

**Engine Temperature Lamps Stays Off:**

Bulb Burned Out  
Loose Wire Connection  
Malfunctioning Circuit Board  
Defective Engine Belt Break Switch

**Engine Oil Pressure Lamp Stays Off:**

Bulb Burned Out  
Malfunctioning Circuit Board  
Defective Engine Oil Pressure Switch  
Engine Malfunctioning

# SECTION 9

# 4IR18N ENGINE

## CONTENTS

### **FOREWORD**

### **EXTERNAL VIEW : 4IR18N**

### **GENERAL INFORMATION: 4IR18N**

Main data and specifications

Engine identification

Ingersoll-Rand engine after sales support

### **EMISSION CONTROL LABEL**

### **FUEL, LUBRICANT, AND COOLANT**

Fuel

Lubricant

Coolant

### **OPERATION**

Check before operation

Check and operation after start- up

Operation and care of a new engine

### **PERIODICAL INSPECTION AND MAINTENANCE**

Lubricating system

Cooling system

Fuel system

Air intake system

Routine maintenance

### **MAINTENANCE SCHEDULE**

### **TROUBLESHOOTING**

## **FORWARD**

*The INGERSOLL-RAND industrial diesel engines are a product of long years of experience, advanced technology, and up-to date production facilities. INGERSOLL-RAND takes great pride in the superior durability and operating economy of these engines.*

*In order to get the fullest use and benefit from your engine, it is important that you operate and maintain it correctly. This Manual is designed to help you do this.*

*Please read this Manual carefully and follow its operating and maintenance recommendations. This will ensure many years of trouble-free and economical engine operation.*

*Should your engine require servicing, please contact your nearest INGERSOLL-RAND branch or distributor.*

*All information, illustrations, and specifications contained in this Manual are based on the latest product information available at the time of publication.*

*INGERSOLL-RAND reserves the right to make changes in this Manual at any time without prior notice.*



## EXTERNAL VIEWS

### DIESEL ENGINE Engine External View - Model

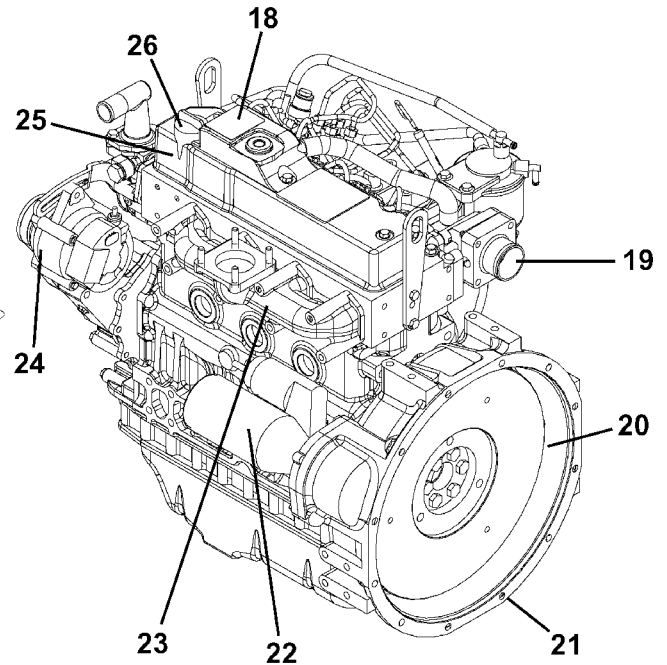
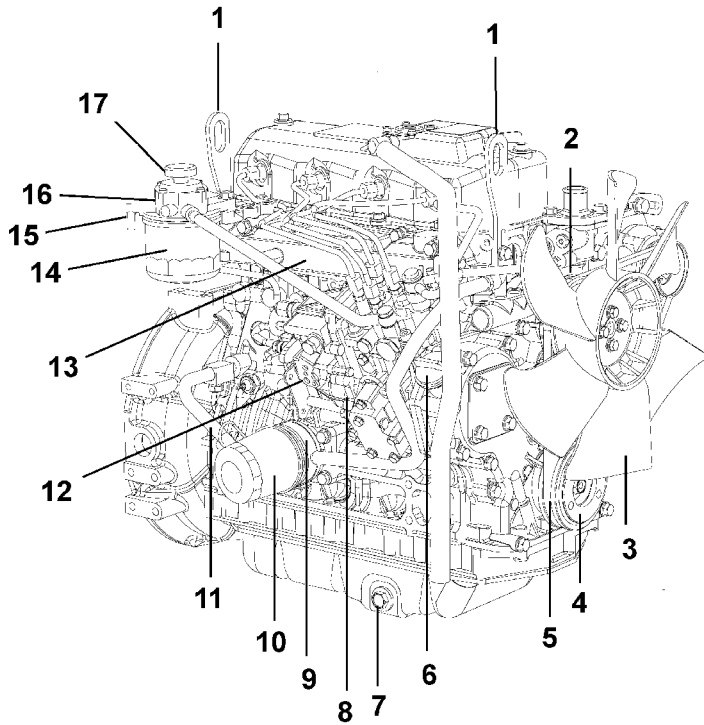

1. Lifting eye
2. Cooling water pump
3. Cooling fan
4. Crank shaft V-pulley
5. V-belt
6. Filler port (engine oil)
7. Drain plug (engine oil)
8. Fuel injection pump
9. Engine oil cooler (**4IRH8N**)
10. Engine oil filter
11. Dipstick (engine oil)
12. Governor lever
13. Intake manifold
14. Fuel filter
15. Fuel oil inlet
16. Fuel filter mounting with fuel priming pump
17. Fuel priming pump
18. Engine name plate
19. Air intake port
20. Flywheel
21. Flywheel housing 3IRH8N, 4IRH8N & 4IRI8N
22. Starter motor
23. Exhaust manifold
24. Alternator

25. Rocker arm cover
26. Filler port (engine oil)

## EPA CERTIFIED ENGINE DATA and SPECIFICATIONS GENERAL INFORMATION

### Model: 4IRI8N

Engine model name	4IRI8N	
Engine type	Vertical inline water cooled diesel engine	
Combustion type	Direct injection	
No. of cylinders - bore x stroke. mm	4-98x110	
Engine displacement L	3.319	
Compression ratio	18.1:1	
Firing order	1 - 3 - 4 - 2	
Exhaust emission control system	Fuel injection nozzles, fuel injector pump	
Governor	Mechanical type	
Injection nozzles	Hole type	
Specified fuel	Diesel fuel (ISO 8217 DMA, BS2869 A1/A2)	
Starter (V-kW)	12-2.3	
Alternator (V-A)	12-40	
Specified engine oil (API grade) (SAE grade)	(CD,CF) (10W-30 or 15W-40)	
Coolant volume (Engine only) L	4.2	
Engine dry weight kg	220	
	Overall length mm	719
Engine dimensions	Overall width mm	508
	Overall height mm	717
Valve clearance (cold) mm	0.2 ± 0.05	
Nozzle injection pressure MPa	21.6	
Injection timing B.T.D.C. at 2.5mm cam lift	15.3° +/-1	

### ENGINE IDENTIFICATION

#### Serial No Location

The engine serial number is stamped on engine name plate on top of rocker cover. See illustration on page NO TAG

#### Confirmation of Engine Number

It is advisable to quote the engine serial number together with the machine serial number, as it is required when you contact the Ingersoll-Rand branch or distributor for repair, service or parts ordering.

**CAUTION:** Conduct confirmation of engine serial number with the engine stopped. To avoid being injured, do not check it, while the engine is still hot.

### INGERSOLL-RAND ENGINE AFTER SERVICE

Please feel free to contact your Ingersoll-Rand dealer for periodical inspection and maintenance.

#### Ingersoll-Rand Genuine Parts

Genuine Ingersoll-Rand parts are identical with those used in the engine production, and accordingly, they are warranted by Ingersoll-Rand.

Genuine Ingersoll-Rand parts are supplied by your Ingersoll-Rand branch or distributor.

Please ensure that only genuine Ingersoll-Rand parts, lubricants and fluids are used for service and/or repair.

**ENGINE LABEL (FOR EPA) EMISSION CONTROL LABEL**

Emission control label is attached on the “top of rocker arm cover.”

The location of emission control label attached on the engine may vary depending on the engine specification

The following is the sample of a label required for engine emission control information, along with location.

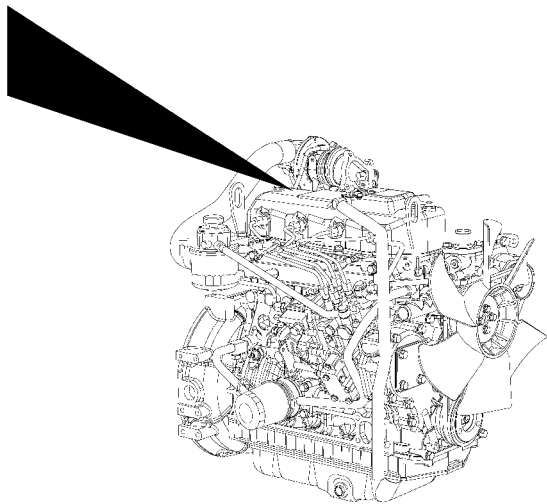
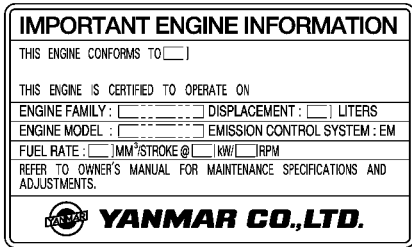

\* Engine family name as assigned by EPA and ARB identifying engine family group 3YDXL1.33M3N and this identifies

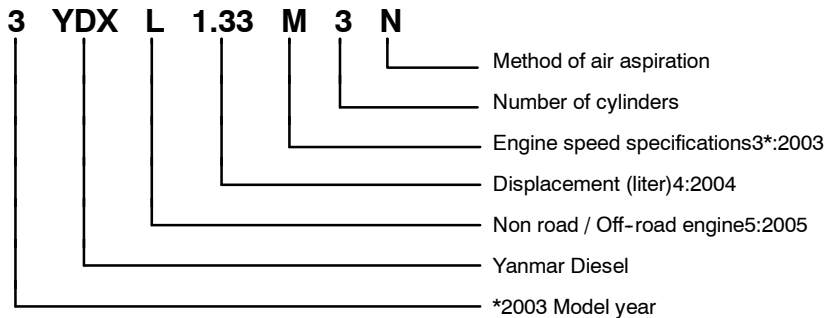

• Label location:

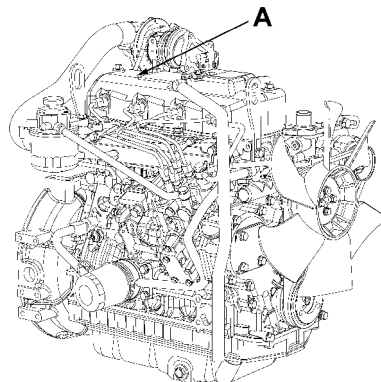

**A.** Emission control information label (4IRH8N, 4IRI8N)

# FUEL, LUBRICANTS, and COOLANT

## FUEL

### Fuel Selection

The following properties are required of the diesel fuel.

Must be free from minute dust particles.

Must have adequate viscosity.

Must have high cetane value.

Must have high cetane value., (45 or greater)

Must have high fluidity at low temperature.

Must have low sulphur content.

Must have little residual carbon.

It is strongly advisable to use ASTM D975 No. 2D (the general automotive diesel engine purpose fuel oil) or equivalent which fully meets the above requirements.

Applicable Standard	Recommendation
JIS (Japanese Industrial Standard)	K22O4 - 2
DIN (DEUTSCHE INDUSTRIE NORMEN)	DIN 51601
SAE (Society of Automotive Engineers) Based on SAE-J-313C	NO. 2-D
BS (BRITISH STANDARD) Based on BS/2869-1970	Class A-1 or A-2
ISO 8217	DMA

### FUEL REQUIREMENTS

Notice: the fuel injection pump, injector or other parts of the fuel system and engine can be damaged if you use any fuel or fuel additive other than those specifically recommended by Ingersoll-Rand.

**NOTE:** If any fuel other than the one specified is used, engine operation will be impaired. Engine failure or malfunction resulting from use of such improper fuel will not be warranted by Ingersoll-Rand.

To help avoid fuel system or engine damage, please read the following:

Do not use diesel fuel which has been contaminated with engine oil. Besides causing engine damage, such fuel can also affect emission control. Before using any diesel fuel, check with the fuel supplier to see if the fuel has been mixed with engine oil.

Your engine is designed to use either Number 1-D or Number 2-D diesel fuel. However, for better fuel economy, use Number 2-D diesel fuel whenever possible. At temperatures less than -7°C, (20°F), Number 2-D fuel may pose operating problems (see "Cold Weather Operation" which follows). At colder temperatures, use Number 1-D fuel (if available) or use a "winterized" Number 2-D (a blend of Number 1-D and Number 2-D). This blended fuel is usually called Number 2-D also, but can be used in colder temperatures than Number 2-D fuel which has not been "winterized."

Check with the fuel supplier to be sure you get the properly blended fuel.

**NOTICE: Do not use home heating oil or gasoline in your diesel engine; either may cause engine damage.**

### Handling of the Fuel.

Any fuel containing dust particles or water might cause engine failure .

Therefore, the following must be observed.

Take care to protect the fuel from ingress of dust particles or water when filling the fuel tank.

If refueling is done from an oil drum directly, ensure that it has been kept stationary to allow any dust, sediment or water to settle at the bottom. Do not draw fuel direct from the bottom of the drum to prevent pickup of any settled foreign material.

Always fully fill the fuel tank. Drain the sedimented particles in the fuel tank frequently.

### Water in Fuel

During refueling, it is possible for water (and other contaminants) to be pumped into your fuel tank along with the diesel fuel. This can happen if a fuel provider does not regularly inspect and clean its fuel tanks, or receives contaminated fuel from its supplier(s). To protect your engine from contaminated fuel, there is a fuel filter system on the engine which allows you to drain excess water.

**CAUTION:** The water/diesel fuel mixture is flammable, and could be hot. To avoid personal injury and/or property damage, do not touch the fuel coming from the drain valve, and do not expose the fuel to open flames or sparks.

Be sure you do not overfill the fuel tank. Heat (such as from the engine) can cause the fuel to expand. If the tank is too full, fuel could be forced out. This could lead to a fire and the risk of personal injury and/or equipment damage.

### Biocides

In warm or humid weather, fungus and/or bacteria may form in diesel fuel if there is water in the fuel.

**NOTICE:** Fungus or bacteria can cause fuel system damage by plugging the fuel lines, fuel filters or injector. They can also cause fuel system corrosion.

If fungus or bacteria has caused fuel system problems, you should have your authorized dealer correct these problems. Then, use a diesel fuel biocide to sterilize the fuel system (follow the biocide manufacturer's instructions). Biocides are available from your dealer, service stations, parts stores and other automotive places. See your authorized dealer for advice on using biocides in your area and for recommendations on which biocides you should use.

### Smoke Suppressants

The use of a smoke suppressant additive is not allowed because of the greater possibility of stuck rings and valve failure, resulting from excessive ash deposits.

**LUBRICANT.**

The quality of engine oil can affect engine performance, startability and engine life.

Use of unsuitable engine oil will result in piston ring, piston and cylinder seizure and accelerate surface wear causing increased oil consumption, lowered output and, finally engine failure. To avoid this, use the specified engine oil.

1) Engine Oil Selection

**Pro Tec™**

2) Oil Viscosity

Engine oil viscosity affects engine startability, performance, oil consumption, wear and the potential for seizure, etc. Always ensure that lubricants with the correct viscosity for the operating temperature are used. Refer to fig 12.

**NOTE**

Using a mixture of different brands or quality of oils will adversely affect the original oil quality; therefore, never mix different brand or different type oils.

Do not use API, CA, CB grade and reconstituted engine oil

Engine damage due to improper maintenance, or using oil of the improper quality and/or viscosity, is not covered by the warranty.

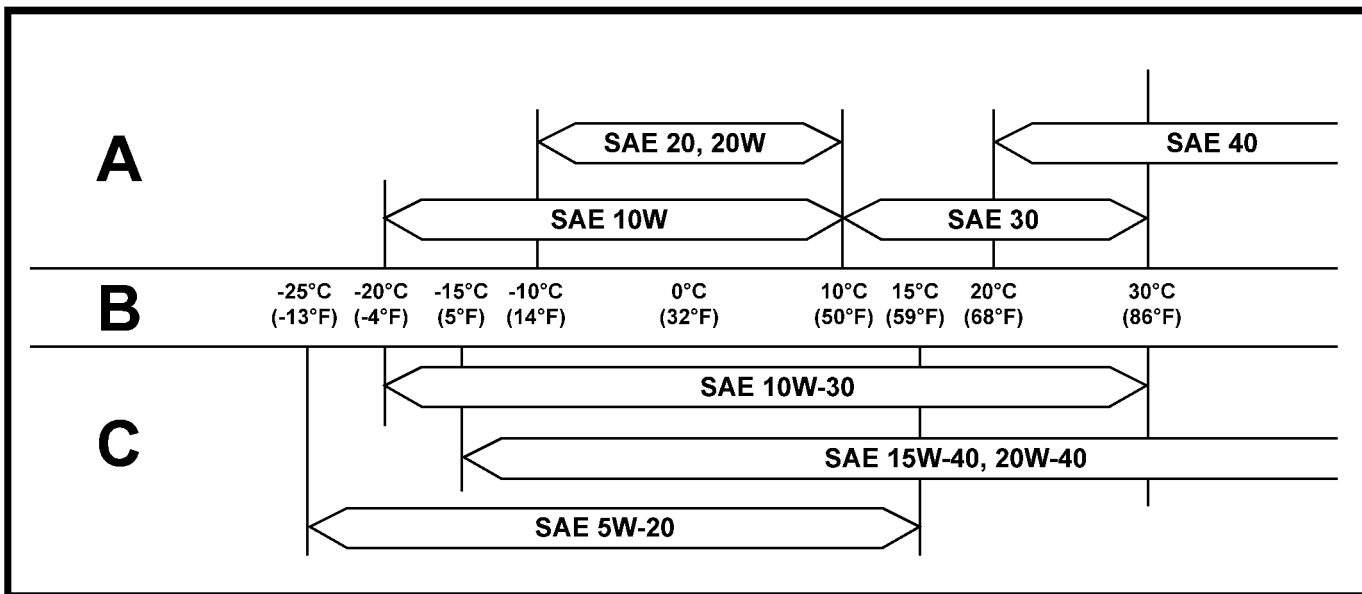

Fig. 12

- A. (Single - grade)
- B. Ambient Temperature
- C. (Multi - grade)

**COOLANT**

All Ingersoll-Rand portable compressor engines are factory filled with a 50/50 Ethylene glycol base antifreeze/water mix. which provides protection to -33°C (-27°F)

**IMPORTANT:**

- Be sure to add Long Life Coolant Antifreeze (LLC) to soft water. In cold season, the LLC is especially important. Without LLC, cooling performance will decrease due to scale and rust in the cooling water line. Without LLC, cooling water will freeze and expand to break the cooling line.
- Be sure to use the mixing ratios specified by the LLC manufacturer for your temperature range.
- Do not mix different types (brand) of LLC, chemical reactions may make the LLC useless and engine trouble could result
- Replace the cooling water every once a year

**CAUTION:**

When handling Long Life Coolant Antifreeze, wear protective rubber gloves not to contact with it. If contact with the eyes or skin should occur, wash with clean water

## ENGINE OPERATION

### Engine Exhaust Gas Caution (Carbon Monoxide)

#### WARNING

Do not breathe exhaust gas because it contains carbon monoxide, which by itself has no color or odor. Carbon monoxide is a dangerous gas. It can cause unconsciousness and can be lethal.

Do not run the engine in confined areas (such as garages or next to a building). Keep the exhaust tailpipe area clear of snow and other material to help reduce the buildup of exhaust gases under the equipment. This is particularly important when parked in blizzard conditions.

## CHECK BEFORE OPERATION

**CAUTION:** For safety reasons, conduct the inspection with the engine stopped.

### Engine Oil Level.

Place the engine or the machine on a level surface

Remove the dipstick, wipe it with a cloth. Insert it fully and take it out gently again.

Check the oil level against the marks on the dipstick. The oil level must be between the upper level mark and the lower level mark as illustrated.

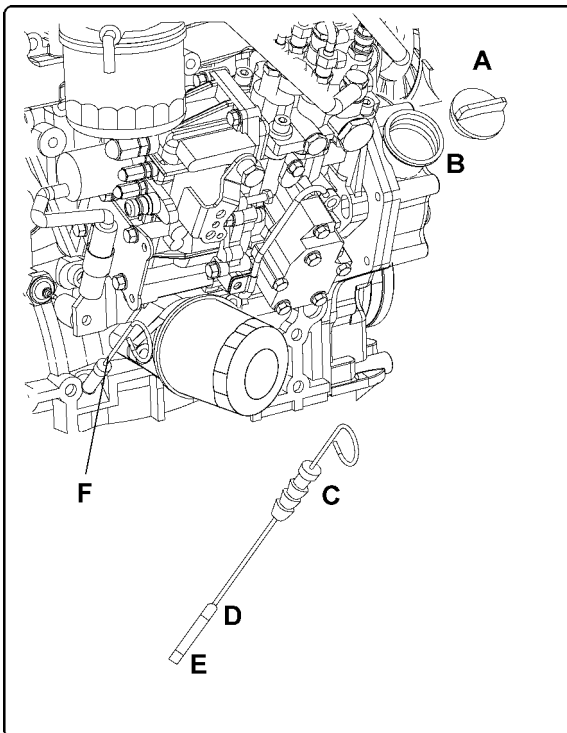

- A. Filler cap
- B. Filler port (engine oil)
- C. Dipstick
- D. Upper limit
- E. Lower limit
- F. Dipstick

Remove filler cap (yellow coloured) on the rocker arm cover side of engine.

Fill with engine oil up to the upper limit on the dipstick.

Manually tighten the filler cap. Do not use a tool such as pliers to tighten it.

Table of oil pan capacities.

Engine oil pan capacity (oil pan) (L)	
4IR18N	10.2

A certain period of time is required before the engine oil completely flows down from the oil filler to the crankcase. Wait at least ten minutes before checking the oil level.

**NOTE:** Take care to avoid engine oil being splashed on the fan drive belt because it causes belt slippage or slackness.

**CAUTION:** When adding oil, take care not to spill it. If you spill oil on the engine or equipment, wipe it properly, to prevent the risk of fire and personal injury and/or equipment damage.

### Fan Belt Check

Check the fan belt for tension and abnormalities.

When the belt is depressed 7 - 10 mm with the thumb (about 100 N [10 kg] pressure) midway between the fan pulley and alternator pulley, the belt tension is correct.

If the belt tension is too high, it will result in alternator failure.

A loose belt will cause belt slippage which may result in a damaged belt, abnormal noise, poor battery charging and engine overheating.

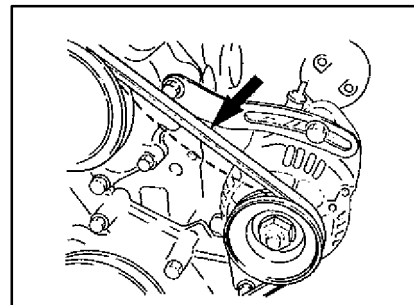

Fig. 16

### Coolant Level Check

The coolant level must be between "MAX COLD" and "MIN" marks on the reserve tank depending on the temperature of the engine. Check and ensure that the level is correct.

**CAUTION:** When removing the radiator filler cap, while the engine is still hot, cover the cap with cloth, then turn it slowly to gradually release the internal steam pressure. This will prevent anyone from being scalded by hot steam spurting out from the filler neck.

Add coolant mixed to the correct ratio: 50/50 ethylene glycol/water.

### Radiator Cap Condition

After the replenishment of the coolant, install the radiator filler cap. Make sure the cap is securely installed.

## Battery Cable Connection

Check the battery cable connections for looseness or corrosion. A loosened cable connection will result in hard engine starting or insufficient battery charge. The battery cables must be tightened securely. Never reverse "+" and "-" terminals when reconnecting cables after disconnection. Even a short period of reverse connection will damage the electrical parts.

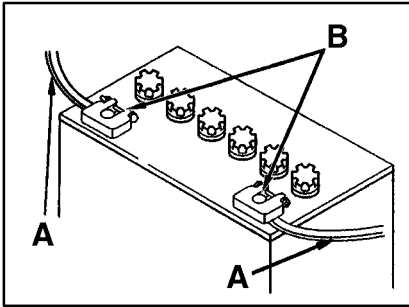

Fig. 17

A Battery cable

B Connections

## Battery Electrolyte level

The amount of electrolyte in the batteries will be reduced after repeated discharge and recharge. Check the electrolyte level in the batteries, replenish with a commercially available electrolyte such as distilled water, if necessary. The battery electrolyte level checking procedure will vary with battery type. NOTICE: Do not replenish with dilute sulfuric acid in the daily service.

### CAUTION:

When inspecting the batteries, be sure to stop the engine first.

As dilute sulphuric acid is used as electrolyte, be careful not to contaminate your eyes, hands, clothes, and metals with the electrolyte. If it gets in your eye, wash with a large amount of water at once, then seek medical advice.

As highly flammable hydrogen gas is released from the batteries, do not create a spark or allow any naked flame near the batteries.

When handling such metallic articles as tools near the batteries, be sure not to contact the "+" terminal because the compressor body is "-" and a dangerous short circuit might result.

When disconnecting the terminals, start with "-" terminal. When connecting them, connect the "-" terminal last.

## Fuel level

Check the remaining fuel oil level in the fuel tank and re-fuel if necessary.

## CHECKS AND OPERATION AFTER START-UP

### Check after the Engine Start-up

Check the following items in the engine warming-up operation.

#### Engine noise and exhaust smoke color -

Listen to the engine and, if any abnormal noise is heard, check to determine the cause.

Check the fuel combustion condition by observing the exhaust smoke color. The exhaust smoke color after engine warm-up and at no-load condition should be colorless or light blue.

Black or white smoke indicates incorrect combustion.

**Note:** After start-up from cold the engine might be noisier and the exhaust smoke color darker than when it has warmed up. However this condition will disappear after warm up.

#### Leakage in the systems -

Check the following items:

Lubrication oil leakage -

Check the engine for oil leaks, paying particular attention to oil filter and oil pipe joints.

Fuel leakage -

Check the fuel injection pump, fuel lines and fuel filter for leakage.

Coolant leakage - Check the radiator and water pump hose connections and the water drain cock on the cylinder block for leakage.

Exhaust smoke or gas leakage

#### Checking coolant level

The coolant level could drop because any mixed air is expelled in about 5 minutes after the engine started.

Stop the engine, remove radiator cap, and add coolant.

**CAUTION:** Hot steam can rush out and you could get burnt if the radiator cap is removed when the engine is hot. Cover the radiator cap with a thick cloth and loosen the cap slowly to reduce the pressure, then remove the cap.

## OPERATION AND CARE OF A NEW ENGINE.

Your Ingersoll-Rand engine is carefully tested and adjusted in the factory, however, further run-in is necessary. Avoid any harsh engine operation within the initial 100 operating hours.

Do not operate the unit at full load until the engine is warmed-up.

Do not allow the engine to run unloaded for extended periods so as to minimise the risk of cylinder bore glazing.

During operation, pay attention to the following points if the engine shows any sign of abnormalities.

**(1) Engine Oil Pressure** - The engine oil pressure is monitored by a switch that will stop the engine if the pressure falls below a pre-set value.

**(2) Coolant Temperature** - The engine performance will be adversely affected if engine coolant temperature is too hot or too cold. The normal coolant temperature is 75 to 85°C (167 to 185°F).

### Overheating

#### CAUTION:

If you see or hear escaping steam or have other reason to suspect there is a serious overheat condition, stop the engine immediately.

If the Engine Coolant Temperature gage (where fitted) shows an overheat condition, or you have reason to suspect the engine may be overheating, take the following step:

- Close the service valve to reduce the load.
- Let the engine run at normal idle speed for two or three minutes. If the engine coolant temperature does not start to drop, turn off the engine and proceed as follows:

**CAUTION:** To help avoid being burned -

- Do not open the canopy or door if you see or hear steam or engine coolant escaping. Wait until no steam or engine coolant can be seen or heard before opening the engine canopy or door.
- Do not remove the radiator filler cap if the engine coolant in the reserve tank is boiling. Also do not remove the radiator filler cap while the engine and radiator are still hot. Scalding fluid and steam can be blown out under pressure if either cap is taken off too soon.

If no steam or engine coolant can be seen or heard, open the canopy or door. If the engine coolant is boiling, wait until it stops before proceeding. The engine coolant level should be between the "MAX COLD" and "MIN" marks on the reserve tank.

Make sure the fan belt is not broken, or off the pulley, and that the fan turns when the engine is started. If the engine coolant level in the reserve tank is low, look for leaks at the radiator hoses and connections, radiator, and water pump. If you find major leaks, do not run the engine until these problems have been corrected. If you do not find a leak or other problem, WAIT UNTIL THE ENGINE HAS COOLED DOWN then carefully add engine coolant to the reserve tank.

(Engine coolant is a mixture of ethylene glycol antifreeze and water. See "Engine Care in cold season" for the proper antifreeze and mixture.)

**CAUTION:** To avoid being burned, do not spill antifreeze or engine coolant on the exhaust system or hot engine parts. Under some conditions the ethylene glycol in engine coolant is combustible.

If the engine coolant level in the reserve tank is at the correct level but there is still an indication of an overheat condition and no cause was found, please consult your local Ingersoll-Rand branch or dealer.

### Overcooling

Operating the engine at low coolant temperature will not only increase the oil and fuel consumption but also will lead to premature parts wear which may result in engine failure. Ensure that the engine reaches normal operating temperature 75 to 85°C (167 to 185°F) within ten minutes of starting.

### (3) Hourmeter

This meter indicates the machine operation hours. Make sure that the meter is always working during engine operation. Periodical machine maintenance is scheduled on the operation hours indicated on the hourmeter.

### (4) Liquid and Exhaust Smoke Leakage

Make regular checks for lubricant, fuel, coolant and exhaust smoke leakage.

### (5) Abnormal Engine Noise

In the event of any abnormal engine noise, please consult your local Ingersoll-Rand branch or dealer.

### (6) State of the Exhaust Smoke

Check for any abnormal exhaust smoke color.

## ENGINE STOPPING

(1) Close service valves.

(2) Before stopping the engine, cool down the engine by operating it at reduced load about three minutes. In this period, check the engine noise for abnormalities.

## LONG TERM STORAGE

If the equipment is to be out of operation for an extended period, it should be started at least once per week and run on load for about 15 minutes after it has reached normal operating temperature.

If this is not possible,

- Do not drain the cooling water
- Clean dust or oil from the engine extension
- Either fill completely or drain the fuel tank
- Grease accelerator joints and electrical connections
- Disconnect the negative battery terminal

*When performing the following items, the daily inspection items should also be carried out.*



# ENGINE MAINTENANCE SCHEDULE

**IMPORTANT:**

Establish a periodic check plan according to the operating conditions and make sure to conduct checks at specified intervals. Otherwise, malfunctioning may occur to shorten the engine life.

As special knowledge and skill are required for items marked with ●, consult your local Ingersoll-Rand branch or distributor.

○: Check    ◇: Replace    ●: Contact your dealer

System	Check item	Daily	Periodic inspection interval				
			Every 50 hours	Every 250 hours	Every 500 hours	Every 1000 hours	Every 2000 hours
Fuel oil	Fuel tank oil level check and refill	○					
	Draining from fuel tank		○				
	Draining from oil / water separator		○				
	Cleaning oil / water separator				○		
	Fuel filter replacement				◇		
Engine oil	Engine oil level	○					
	Engine oil replacement		◇		◇		
	Engine oil filter replacement		1st time		2nd & after		
Cooling water	Check & addition cooling	○					
	Radiator fin checking & cleaning			○			
	Cooling fan V-belt checking & adjusting		○	○			
			1st time	2nd & after			
	Cooling water replacement					◇ or every 1 yr	
Rubber hoses	Fuel & cooling water pipe replacement						● or every 2 yrs
Operating system	Governor lever & accelerator check & adjust	○		○			
Intake and exhaust	Air cleaner element cleaning & replacement			○	◇		
Electrical equipment	Battery electrolyte check and recharging		○				
Cylinder head	Adjust intake / exhaust valve clearance					●	
	Lapping intake / exhaust valve seats						●
Fuel valve pump *	Check fuel injection valve pressure & adjust					●	
	Check & adjust fuel injection pump						●

\* The specific emissions related parts for the EPA/ARB regulations

EPA allows to apply Maintenance schedule for Emission related parts as follows.

-	Check Fuel Valve Nozzle and clean	Adjust, cleaning and repair of fuel injection Pump and fuel valve nozzle
kW ≤ 130	1500 hours of use and at 1500-hour intervals thereafter	3000 hours of use and at 3000-hour intervals thereafter

## PERIODICAL INSPECTION AND MAINTENANCE

### Inspection after initial 50 hours operation

#### (1) Replacing the engine oil and engine oil filter (1st time)

When the engine oil is still hot, be careful with a splash of engine oil which may cause burns. Cool the engine to replace engine oil until the engine oil becomes warm. It is most effective to drain the engine oil while the engine is still warm.

In early period of use, the engine oil gets dirty rapidly because of the initial wear of internal parts. Replace the engine oil earlier.

Engine oil filter should also, be replaced when the engine oil is replaced.

Engine oil and engine oil filter replacing procedures are as follows.

Remove the oil filler cap to drain easily while draining the engine oil.

- 1) Prepare a waste oil container collecting waste oil.
- 2) Loosen the drain plug using a wrench (customer procured) to drain the engine oil.
- 3) Securely tighten the drain plug after draining the engine oil.
- 4) Turn the engine oil filter counter-clockwise using a filter wrench (customer procured) to remove it.
- 5) Clean the engine oil filter mounting face.
- 6) Moisten the new engine oil filter gasket with the engine oil and install the new engine oil filter manually turning it clockwise until it comes into contact with the mounting surface, and tighten it further to 3/4 of a turn with the filter wrench.

Tightening torque: 19.6~23.5N•m (2.0~2.4kgf•m)

Applicable engine oil filter Part No 22226351.

- 7) Fill with the new engine oil until it reaches the specified level as explained in OPERATION section.

#### **IMPORTANT:**

*Do not overfill the oil pan with engine oil. Be sure to keep the specified level between upper and lower limit on the dipstick.*

- 8) Warm up the engine by running for 5 minutes while checking any oil leakage.
- 9) Stop the engine after warming up and leave it stopping for about 10 minute to recheck the engine oil level with dipstick and replenish the engine oil. If any oil is spilled, wipe it away with a clean cloth.

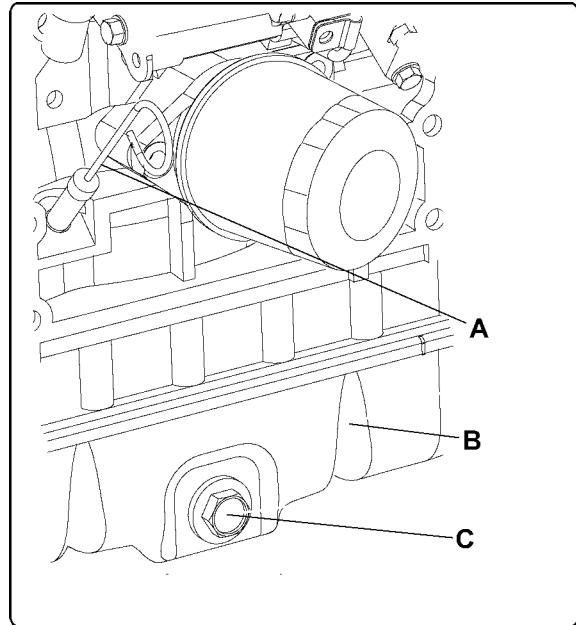

The location depends on the engine installed on the machine unit

- A. Dipstick
- B. Oil pan
- C. Drain plug

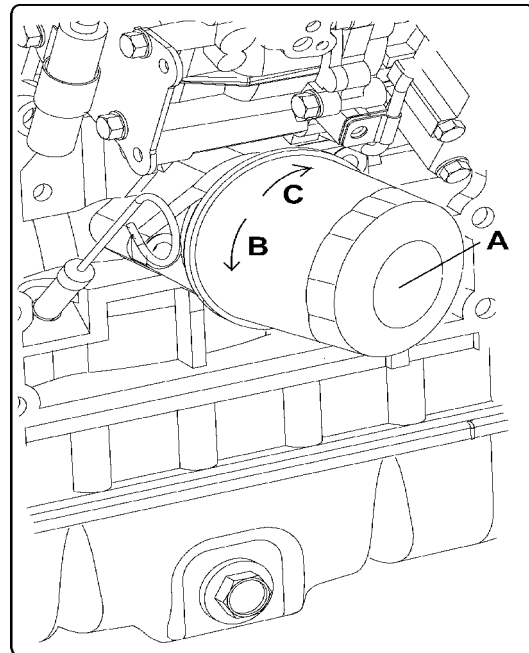

- A. Engine oil filter
- B. Loosen
- C. Tighten

**(2) Checking and adjusting cooling fan V-belt**

When there is not enough tension in the V-belt, the V-belt will slip making it impossible for the alternator to generate power and cooling water pump and cooling fan will not work causing the engine to overheat. Check and adjust the V-belt tension (deflection) in the following manner.

1) Press the V-belt down with your thumb [approx. 98N(10kgf)]. at the middle of the V-belt span to check the tension (deflection).

Available positions to check and adjust the V-belt tension (deflection) are at the A, B and C showing with the arrow direction as shown illustration right.

You may choose a position whichever you can most easily carry out the check and adjustment on the machine unit.

The specified deflection to be measured at each position should be as follows.

A	B	C
10~14mm	7~10mm	9~13mm

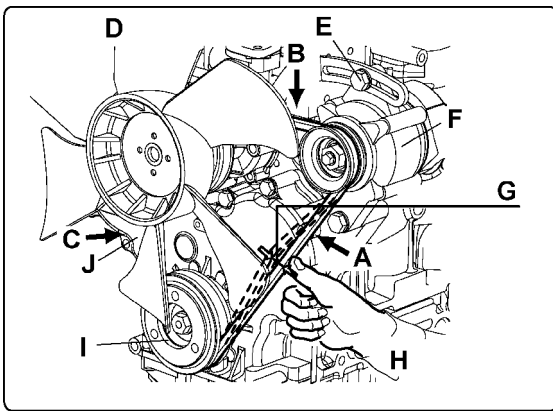

- D. Radiator fan
- E. Set bolt
- F. Alternator
- G. Deflection
- H. Press with thumb
- I. Crankshaft V-pulley
- J. V-belt

2) If necessary, adjust the V-belt tension (deflection). To adjust the V-belt tension, loosen the set bolt and move the alternator to tighten the V-belt.

3) Visually check the V-belt for cracks, oiliness or wear. If any, replace the V-belt with new one.

- "New, V-belt" refers to a V-belt which has been used less than 5 minutes on a running engine.

- "Used V-belt" refers to a V-belt which has been used on a running engine for 5 minutes or more.

Install the new V-belt adjusting the deflection to the value in the table below according to the above manner. After adjusting, run the engine for 5 minutes end readjust the deflection to the value in the table above.

A	B	C
8~12mm	5~8mm	7~11mm

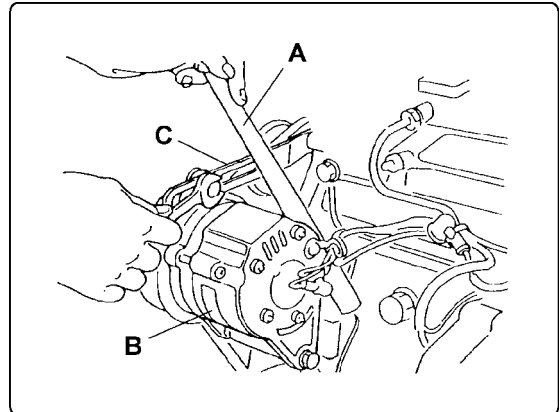

(Adjusting the V-belt tension)

- A. Adjust the V-belt tension by prying with a wooden bar
- B. Alternator
- C. Adjusting bracket

**Use of genuine Ingersoll-Rand fan belt**

Always use genuine Ingersoll-Rand fan belts as they provide high driving ability and long operating durability. Use of non-Ingersoll-Rand fan belts could result in premature belt wear or belt elongation leading to engine overheating or excessive belt noise.

**CAUTION:**  
To help avoid being injured, check and adjust the fan belt tension with engine stopped.

## Inspection every 50 hours operation

### (1) Draining of the fuel tank (NOT 7/26)

- 1) Prepare a waste oil container.
- 2) Remove the drain plug of the fuel tank to drain (water, dust ,etc.) from the fuel tank bottom.
- 3) Drain until fuel with no water and dust flow out. Then tighten the drain plug firmly.

### (2) Draining of the oil/water separator

#### Draining Water from Fuel Filter/separator.

The fuel filter/separator is provided to allow water to be drained from the fuel system. Water is heavier than fuel so any water contained in the system will collect in the bottom of the bowl.

The clear bowl 'D' should be checked on a daily basis and if water is present, it should be drained from the separator.

Place a suitable container under the separator to prevent any spillage inside the machine.

Slacken the drain valve 'E' until water drains from the vent tube.

When all the water has been evacuated, tighten the drain valve 'E' and follow the "fuel system air bleeding" procedure below.

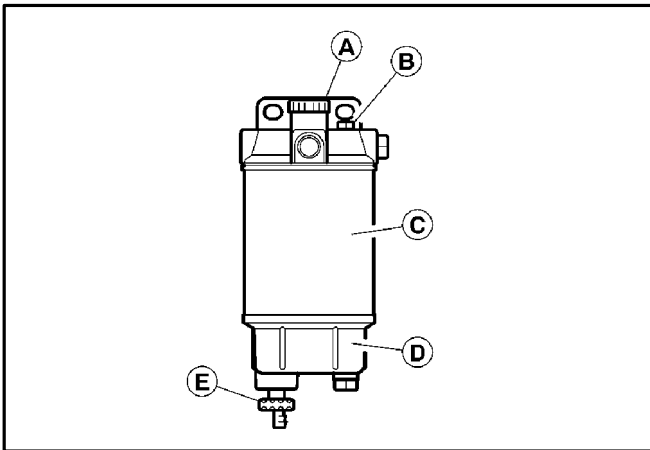

#### Fuel System Air Bleeding

The entry of air into the fuel system will cause difficult engine starting or engine malfunction.

When carrying out service procedures such as emptying the fuel tank, draining the filter/separator, and changing the fuel filter element be sure to bleed air from the fuel system.

To activate the "automatic air-bleeding system", turn the key switch to the "ON" position and energize the electromagnetic pump" to bleed the air.

Air bleeding method:

When the "starter switch" is set to the "ON" position to activate the electromagnetic pump, fuel is forced to the fuel valve of each injection pump and then to the leak-off pipe of each injector nozzle, so that any air in the fuel system bleeds off automatically to the fuel tank.

#### NOTE:

Although the fuel system can bleed air automatically when the key switch is in the "ON" position, air can also be manually bled by use of the primer pump facility in the filter/separator assembly. By unscrewing the plastic primer pump head 'A' and stroking it up and down, any air bubbles in the system will be purged back to the fuel tank. When this has been completed, the pump head must be screwed back into the filter/separator assembly.

Start the engine and visually check the fuel system for leaks.

## Governor Control Seals

As the governor is precisely adjusted, most of the controls are sealed, please do not break them. Should any adjustment be necessary, contact your local Ingersoll-Rand branch or distributor.

**NOTE: Ingersoll-Rand will not accept any warranty claim on an engine with broken governor seals.**

### (3) Inspection of battery

#### Fire due to electric short-circuit



- Make sure to turn off the battery switch or disconnect the negative cable (-) before inspecting the electrical system. Failure to do so could cause short-circuiting and fires.
- Always disconnect the (-) Negative battery cable first before disconnecting the battery cables from battery. An accidental "Short circuit" may cause damage, fire and or personnel injury.

And remember to connect the (-) Negative battery cable (back onto the battery) LAST.

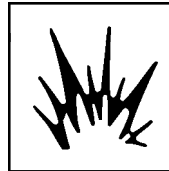

#### Proper ventilation of the battery area

Keep the area around the battery Well ventilated, paying attention to keep away any fire source. During operation or charging, hydrogen gas is generated from the battery and can be easily ignited.



#### Do not come in contact with battery electrolyte

Pay sufficient attention to avoid your eyes, or skin from being in contact with the fluid. The battery electrolyte is dilute sulfuric acid and causes burns. Wash it off immediately with a large amount of fresh water if you get any on you.

- Clean the battery terminals
- Check the level of fluid in the battery. When the amount of fluid nears the lower limit, fill with battery fluid (available in the market) to the upper limit. If operation continues with insufficient battery fluid, the battery life is shortened, and the battery may overheat and explode.
- Battery fluid tends to evaporate more quickly in the summer, and the fluid level should be checked earlier than the specified times.

- If the engine cranking speed is so slow that the engine does not start up, recharge the battery.
- If the engine still will not start after charging, replace the battery.
- Remove the battery from the battery mounting of the machine unit after daily use if letting the machine unit leave in the place that the ambient temperature could drop at  $-15^{\circ}\text{C}$  or less. And store the battery in a warm place until the next use the unit to start the engine easily at low ambient temperature.

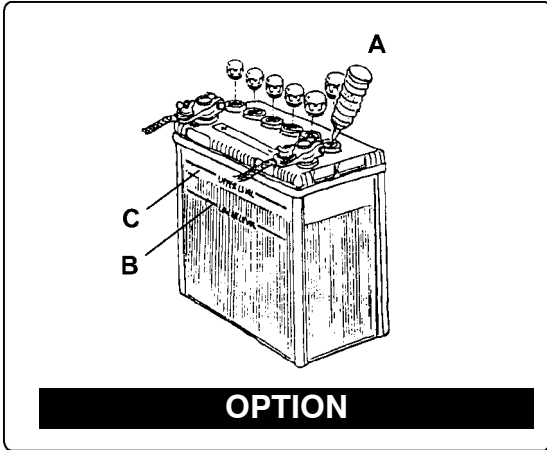

Follow the instructions and precautions in the manual from the battery maker.

- A. Battery fluid
- B. Lower limit
- C. Upper limit

## Inspection every 250 hours operation

### (1) Replacing the engine oil and engine oil filter (2nd time and after)

Replace the engine oil every 250 hours operation from 2nd time and on. Replace the engine oil filter at the same time. Refer to 50 hour inspection, section (1).

### (2) Checking and cleaning radiator fins.

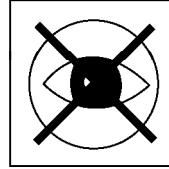

#### Beware of dirt from air blowing

Wear-protective equipment such as goggles to protect your eyes when blowing compressed air. Dust or flying debris can hurt eyes.

Dirt and dust adhering on the radiator fins reduce the cooling performance, causing overheating. Make it a rule to check the radiator fins daily and clean as needed.

- Blow off dirt and dust from fins and periphery with compressed air [0.19MPa (2kgf/cm<sup>2</sup>) or less] not to damage the fins with compressed air.
- If contaminated heavily, apply detergent, thoroughly clean and rinse with tap water shower.

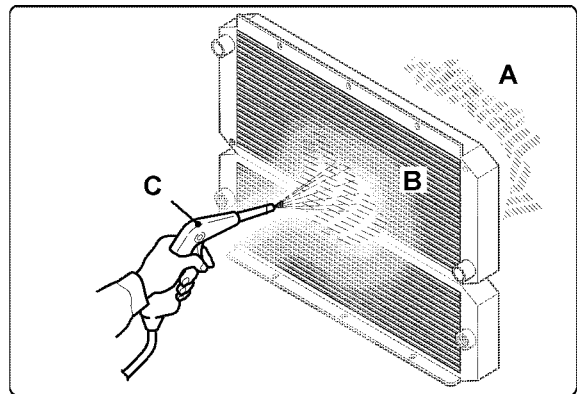

- A. Dust, dirt.
- B. Radiator fins
- C. Air blow

#### **IMPORTANT:**

Never use high pressure water or air from close by fins or never attempt to clean using a wire brush. Radiator fins can be damaged.

### (3) Checking the governor lever and accelerating device.

The governor lever and accelerating devices (accelerating lever, pedal, etc.) of the machine unit are connected by a fixed linkage to a pneumatic actuator. If the linkage becomes loose, the deviation in the position may result and make operation unsafe. Check the linkage connections for excess play. For adjustment of linkage see compressor operation section.

#### Governor Control Seals

As the governor is precisely adjusted, most of the controls are sealed, please do not break them. Should any adjustment be necessary, contact your local Ingersoll-Rand branch or distributor.

**NOTE: Ingersoll-Rand will not accept any warranty claim on an engine with broken governor seals.**

### (4) Replacing fuel filter

Replace the fuel filter at specified intervals before it is clogged with dust to adversely affect the fuel flow. Also, replace the fuel filter after the engine has fully been cooled.

- 1) Remove the fuel filter using a filter wrench(customer procured). When removing the fuel filter, hold the bottom of the fuel filter with a piece of rag to prevent the fuel oil from dropping. If you spill fuel, wipe such spillage carefully.
- 2) Clean the filter mounting surface and slightly apply fuel oil to the gasket of the new fuel filter.
- 3) Install the: new fuel filter manually turning until it comes into contact with the mounting surface, and tighten it further to 1/2 a turn, using a filter wrench. Tightening torque: 11.8~15.6N•m(1.2~1.6kgf•m)

Applicable fuel filter Part No: 22226369.

- 4) Bleed the fuel system. Refer to section 2 of inspection at 50 hours

#### IMPORTANT:

Be sure to use genuine IR part (super fine mesh filter). Otherwise, it results in engine damage, uneven engine performance and shorter engine life.

### (5) Changing oil/water separator element.

#### NOTE:

The cartridge and bowl contain fuel. Take care not to spill it during disassembly and reassembly.

The fuel filter/separator also provides primary filtration and the element 'C' should be changed every 500 operating hours or 6 months, whichever comes first.

Change procedure:

Unscrew the element 'C' from the head taking care not to spill fuel inside the machine. Drain any fuel within into a suitable container, then unscrew the clear bowl 'D' from the element.

Discard the old element into a suitable container.

Remove the old 'O' ring from the bowl 'D' and install the new one supplied with the element. Apply a light coat of clean engine oil to the 'O' ring and screw the bowl 'D' onto the new element 'C'.

Using a clean cloth, wipe the sealing face of the filter/separator head to ensure correct seating of the sealing ring.

Fill the element/bowl assembly with clean fuel oil then apply a light coat of clean engine oil to the new element seal ring.

Screw the new element onto the head firmly by hand.

Follow the "fuel system air bleeding" procedure. see "inspection after every 50 hours operation" section 2.

### (6) Air cleaner element inspection

## AIR INTAKE SYSTEM

#### Air cleaner

Engine performance and life vary with the air intake conditions.

A dirty air cleaner element reduces the amount of intake air, causing reduced engine output and possible engine damage.

Also, a damaged element leads to abrasion of cylinders and valves, resulting in increased oil consumption, reduced output and shortened engine life.

#### INSPECT THE CONDITION OF THE ELEMENT.

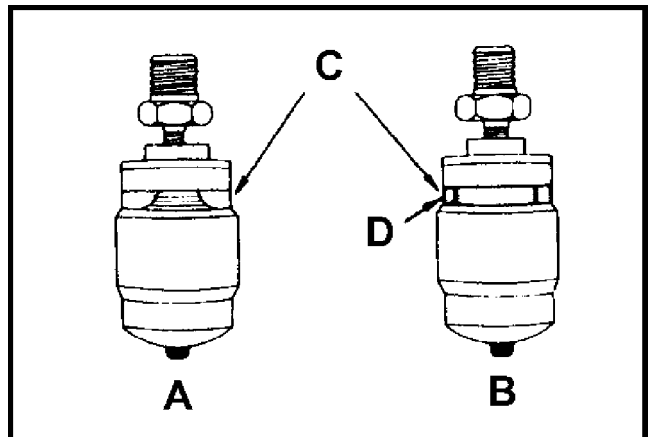

Fig. 32

- A Normal
- B Clogged
- C Indicator
- D Red signal

#### Air cleaner with dust indicator

This indicator is attached to the air cleaner. When the air cleaner element is clogged, air intake resistance becomes greater and the dust indicator signal turns to red indicating the element needs to be changed.

When the signal turns to red, replace the element. Then press the dust indicator button to reset the indication.

### (1) Checking and adjusting cooling fan V-belt (2nd time and after)

Check and adjust the cooling fan V-belt tension every 250 hours operation from 2nd time and on.

See "inspection after initial 50 hours" section (2)

## Inspection every 500 hours operation

### (1) Replacing the air cleaner element

Replace the air cleaner element periodically even if it is not damaged or dirty. When replacing the element, clean the inside air cleaner case at the time. If having the air cleaner with double elements, do not remove the inner element. If the engine output is still not recover (or the dust indicator still actuates if having the air cleaner with a dust indicator) even though the outer element has replaced with new one, replace the inner element with new one.

## Inspection every 1000 hours operation

### (1) Replacing cooling water

Cooling water contaminated with rust or water scale .reduces the cooling effect. Even when antifreeze agent (LLC) is mixed, the cooling water gets contaminated due to deteriorated ingredients. Replace the cooling water at least Once a year.

- 1) Remove the header tank cap.
- 2) Remove the bottom radiator hose of the radiator and drain the cooling water.
- 3) After draining the cooling water, reconnect the hose.
- 4) Fill radiator and engine with cooling water via the header tank.

### Beware of scalding by hot water

Wait until the temperature goes down before draining the Cooling water. Otherwise, hot water may splash to cause scalding.

### (2) Checking and adjusting the fuel injection valve

As the adjustment requires specialized knowledge and skill, .consult your Ingersoll-Rand dealer. This adjustment is needed to obtain the optimum injection pattern for full engine performance.

### (3) Adjusting intake / exhaust valve clearance

As this adjustment requires specialized knowledge and skill, consult your Ingersoll-Rand dealer. The adjustment is necessary to maintain the correct timing for the opening and closing of valves. Neglecting the adjustment will cause the engine to run noisily and result in poor engine performance and other damage.

## Inspection every 2000 hours operation

### (1) Flushing the cooling system and checking the cooling system parts

As this maintenance requires specialized knowledge and skill, consult your Ingersoll-Rand dealer. Rust and water scale will accumulate in the cooling system through many hours of operation. This lowers the engine cooling effect.

And for the engine oil cooler (4TNV98T), they quickly deteriorate the engine oil.

Cooling system parts: radiator, cooling water pump, thermostat, cylinder block, cylinder head, oil cooler (4TNV98T).

### (2) Checking and replacing fuel hoses and cooling water hoses

As this maintenance requires specialized knowledge and skill, consult your Ingersoll-Rand dealer. Regularly check the rubber hoses of the fuel system and cooling water system. If cracked or degraded, replace them with new one. Replace the rubber hoses at least every 2 years.

### (3) Lapping the intake and exhaust valves

As this maintenance requires specialized knowledge and skill, consult your Ingersoll-Rand dealer. The adjustment is necessary to maintain proper contact of the valves and seats.

### (4) Checking and adjusting the fuel injection timing

As this maintenance requires specialized knowledge and skill, consult your Ingersoll-Rand dealer.

### Checking and adjusting the EPA emission related parts.

The inspection and servicing require specialized knowledge and techniques. Consult your Ingersoll-Rand dealer or distributor.

EPA allows to apply maintenance schedule for emission related parts as follow.

-	Check Fuel Valve Nozzle and clean	Adjust, cleaning and repair of Fuel injection Pump and Fuel Valve Nozzle.
kW $\leq$ 130	1500 hours of use and at 1500-hour intervals thereafter	3000 hours of use and at 3000-hour intervals thereafter

**Note:**

★ This is a recommended maintenance. The failure to perform this maintenance item will not nullify the emission warranty or limit recall liability prior to the completion engine useful life. Ingersoll-Rand, however, urges that recommended maintenance service is performed at the indicated intervals.

## EXPLANATION OF MAINTENANCE SCHEDULE

The following is a brief explanation of the services listed in the preceding Engine Maintenance schedule.

- |  |   |
|--|---|
| <b>1. Oil level.</b>                               | Check that the oil level is between the max. and the min. level marks. Add oil to the max. level mark if it is below the min. level. If it is above the max. level mark, drain oil until the max. level is reached. |
| <b>2. Engine oil replacement</b>                   | Change at 500 hours or 6 months, whichever comes first.   |
| <b>3. Oil filter element replacement</b>           | Change at 500 hours or 6 months, whichever comes first.   |
| <b>4. Fuel leakage</b>                             | Replace any damaged or malfunctioning parts which could cause leakage.  |
| <b>5. Draining water in fuel filter/separator.</b> | Drain off water in the fuel filter/separator bowl.  |
| <b>6. Fuel filter element replacement</b>          | Replace both primary (filter/separator) and secondary elements at 500 hours or 6 months whichever come first.   |
| <b>7. Injection nozzle check</b>                   | Check injection opening pressure and spray condition. (This is a recommended maintenance item ★). Consult your local Ingersoll-Rand branch or distributor.  |
| <b>8. Coolant level.</b>                           | Check coolant level and add coolant if necessary.   |
| <b>9. Coolant leakage check</b>                    | Replace any damaged or malfunctioning parts which could cause leakage.  |
| <b>10. Radiator filler cap fitting condition</b>   | The radiator cap must be installed tightly and sealing correctly.   |
| <b>11. Fan belt tension check</b>                  | Check and adjust fan belt deflection. Look for cracks, fraying and wear. Replace if necessary.  |
| <b>12. Coolant temperature</b>                     | Normal running temperature is 75 to 85°C (167 to 185°F). Check and repair the cooling system if temperature is abnormal.  |
| <b>13. Coolant replacement</b>                     | Change coolant at intervals of 1000 hours or 12 months, whichever comes first.  |
| <b>14. Radiator external face cleaning</b>         | Check monthly. Clean at intervals of 250 hours or 3 months, whichever comes first. In very dusty environments, more frequent cleaning might be necessary.   |
| <b>15. Cooling system circuit cleaning</b>         | Clean at intervals of 1000 hours or 12 months, whichever comes first.   |
| <b>16. Radiator filling cap function check</b>     | Check radiator pressure cap periodically for proper operation. Consult your local Ingersoll-Rand branch or distributor.   |
| <b>17. Battery electrolyte level check</b>         | Replenish with distilled water if necessary.  |
| <b>18. Battery cleaning</b>                        | Clean the terminals   |
| <b>19. Battery charge condition</b>                | If cranking speed is too slow to start the engine, charge the battery.  |
| <b>20. Air filter element replacement</b>          | Change element at 500 hrs or sooner if the restriction indicator shows red.   |
| <b>21. Cylinder compression pressure</b>           | Consult your Ingersoll-Rand dealer or distributor   |
| <b>22. Valve clearance check</b>                   | Check and adjust every 1000 hours. Consult your Ingersoll-Rand dealer or distributor  |



This item contains a simple troubleshooting. When a failure takes place on your Ingersoll-Rand engine, diagnose the cause referring this troubleshooting. Should the cause of failure not be detected or you are unable to manage the failure, consult your machine supply source or nearest Ingersoll-Rand engine service outlet.

<b>Engine does not start</b>	Starter does not turn.	Battery discharged	
		Bad cable connections.	
		Starter or starter switch failure.	
		Safety relay failure.	
	Starter turns but engine does not fire.	No fuel injection.	Engine stop solenoid malfunction.
			No fuel in the fuel tank.
			Clogged fuel filter element.
			Air in the fuel system.
			Control rack is stuck at no fuel position.
		Fuel is injected but engine does not fire.	Incorrect preheating operation.
			Faulty air heater.
			Incorrect injection timing.
			Low cylinder compression pressure.
Engine stop solenoid not fully returned.			
Engine fires but stalls immediately.	Air in the fuel system.		
	Incorrect low idle speed adjustment.		

<b>Unstable engine running</b>	Unstable low idling	Crack in injection pipe.	
		Injection nozzle failure.	
		Engine stop solenoid return failure.	
		Uneven compression pressure between cylinders.	
	Incorrect high idle speed adjustment.	Incorrect control lever adjustment.	
		Governor internal malfunction.	
	Engine hunting in medium speed range.	Governor spring deteriorated.	
	Engine malfunction in high speed range.	Insufficient fuel supply.	Air in the fuel system
			Clogged fuel filter element
			Piping failure (squeezed/restricted etc.)
		Uneven fuel injection amount between cylinders.	
		Deteriorated governor spring.	
Incorrect valve clearance adjustment.			
Deteriorated valve spring.			
Engine speed stuck at high idle.	Engine control restriction or seizure.		
<b>Engine overheat.</b>	Cooling system defect	Insufficient coolant volume.	
		Fan belt slippage.	
		Thermostat malfunction.	
		Radiator filler cap malfunction.	
		Cooling system interior fouled.	
		Radiator clogged.	
	Improper servicing	Engine over-loaded.	
		Air cleaner element clogged.	
		Insufficient airflow/restriction.	
		Restricted coolant flow (high concentration of antifreeze, etc.)	
	<b>Low oil pressure</b>	Lack of oil	Oil leakage
High oil consumption			
Wrong oil		Wrong type and viscosity.	
High coolant temperature.		Over heat.	
Clogged filter and strainer.			
Worn bearings and oil pump.			
Faulty relief valve.			

<b>Low engine output</b>	Incorrect injection pump adjustment	Incorrect injection timing	Too far advanced.
			Too far retarded.
		Injection nozzle malfunction	Incorrect injection pressure.
			Incorrect spray condition.
		Insufficient fuel supply to the injection pump	Lack of fuel in tank.
		Air in injection pump.	
		Fuel filter clogged.	
		Overflow valve malfunction.	
		Governor malfunction	Incorrect engine control adjustment.
			Deteriorated governor spring.
Low cylinder compression pressure	Cylinder compression leakage	Incorrect valve clearance adjustment.	
		Injector nozzle misalignment.	
		Cylinder bore wear.	
	Insufficient air intake volume.	Air cleaner clogged.	
		Restricted air flow.	
<b>Excessive oil consumption</b>	Incorrect oil	Wrong selection of type and viscosity.	
		Too much oil quantity.	
	Engine burning oil	Faulty piston rings/damaged cylinder bores.	
		Faulty valve stem seal.	
	Oil leakage	Damaged seal / Damaged turbocharger seal	
		Loose joints/gaskets.	
Improper installation of filter and piping.			
<b>Excessive fuel consumption</b>	Fuel leakage	Damaged seals.	
		Improper component installation or tightening.	
	Excessive injection volume.	Injection pump defective.	
	Excessive mechanical loads		

<b>Improper exhaust</b>	Excessive black smoke	Clogged air cleaner.
		Damaged injector nozzle.
		Wrong injector nozzle.
		Injection timing incorrect.
		Excessive injection volume.
		Incorrect fuel.
	Excessive white smoke	Water mixing in fuel
		Low compression pressure.
		Injection timing incorrect.
		Low coolant temperature
	Faulty turbocharger	
<b>Battery over discharge</b>	Low electrolyte level	Crack in battery body.
		Natural consumption.
	Charging failure	Loose or damaged belt.
		Faulty alternator.
		Damaged wiring or contact failure.
	Excessive electrical loads	Insufficient battery capacity for the application.

## **SECTION 11 - PARTS LIST**

Frame	Coolers Complete
Drawbar Complete	Fan Shroud
Jack Assembly	Airend Complete
Running Gear Complete	Airend Assembly
13" Tire & Wheel	Oil Temperature Bypass valve
15" Tire & Wheel	Seperator Tank Complete
Tail Light Wiring	Service Air Complete
Engine and Exhaust Complete	Fuel / Water Filter
Engine Components:	Fuel Tank Complete
Engine Overhaul Gasket Set	Air Intake Filters, Relays & Fuel Filter Mtg.
Valve Cover	Air Cleaner Assembly
Rocker Arm Asm.	Battery Assembly
Cylinder Head Asm.	Inst/Control Panel
Cylinder Block Asm.	Wiring Diagram
Oil Pan Asm. and Sump Tube	Tail Light Wiring Diagram
Flywheel	Air Piping
Camshaft & Idle Gears	Oil Piping
Crankshaft & Pistons	Enclosure Complete
Timing Gear Housing	Foam Insulation Complete
IntakeManifold	Decal Location
Exhaust Manifold	
Water Pump & Thermostat	
Injection Pump and Fuel Lines	
Fuel Filter	
Oil Filter	
Electrical Components	

# FRAME

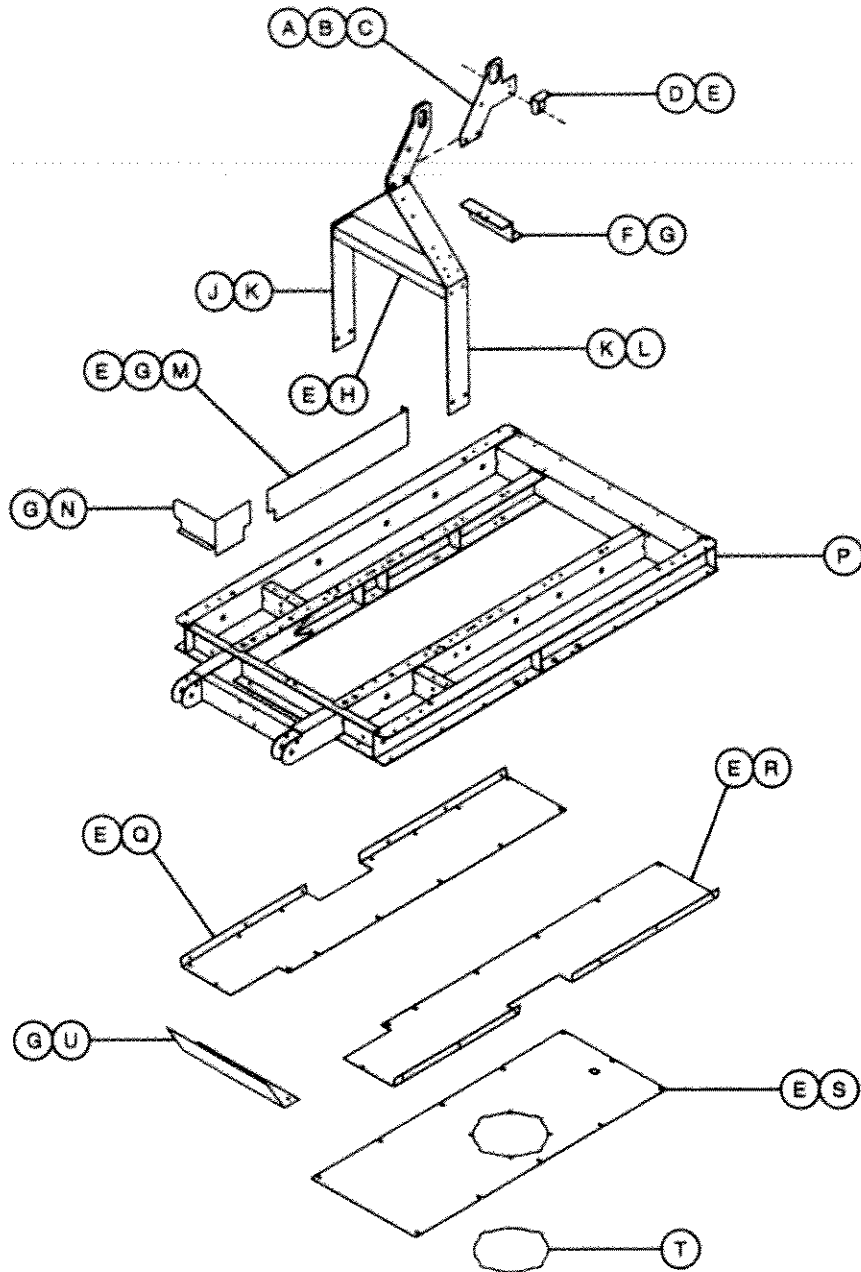

Item	CPN	Qty	Description	Item	CPN	Qty	Description
A	36882165	1	PLATE, BAIL EYE	M	36884708	1	GUARD, TOOL BOX
B	36877793	3	SCREW, HEX FLANGE HD M12 X 40	N	36884716	1	GUARD, BATTERY
C	36879203	3	NUT, HEX FLANGE M12	P	22204614	1	FRAME
D	36883510	1	ANGLE, ROOF TIE	Q	36882678	1	PAN, CRBSD BELLY
E	35279025	43	SCREW, TAPPING M08-1.25 X 20		54529284	1	PAN, CRBSD BELL (GALV)
F	22252183	1	BRACKET, RELAY	R	36882686	1	PAN, STSD BELLY
G	36787652	12	SCREW, TAPPING M06-1.0 X 12		54529292	1	PAN, STSD BELL (GALV)
H	36880870	1	CROSSMEMBER, LIFT BAIL	S	36880441	1	PAN, CENTER BELLY
J	36880854	1	BAIL, CRBSD LIFT		54529086	1	PAN, CENTER BELL (GALV)
K	36789492	4	SCREW, HEX FLANGE HD M12 X 25	T	36880623	1	COVER, FLEXIBLE ACCESS
L	36880862	1	BAIL, STSD LIFT	U	36881423	1	BAFFLE

# DRAWBAR COMPLETE

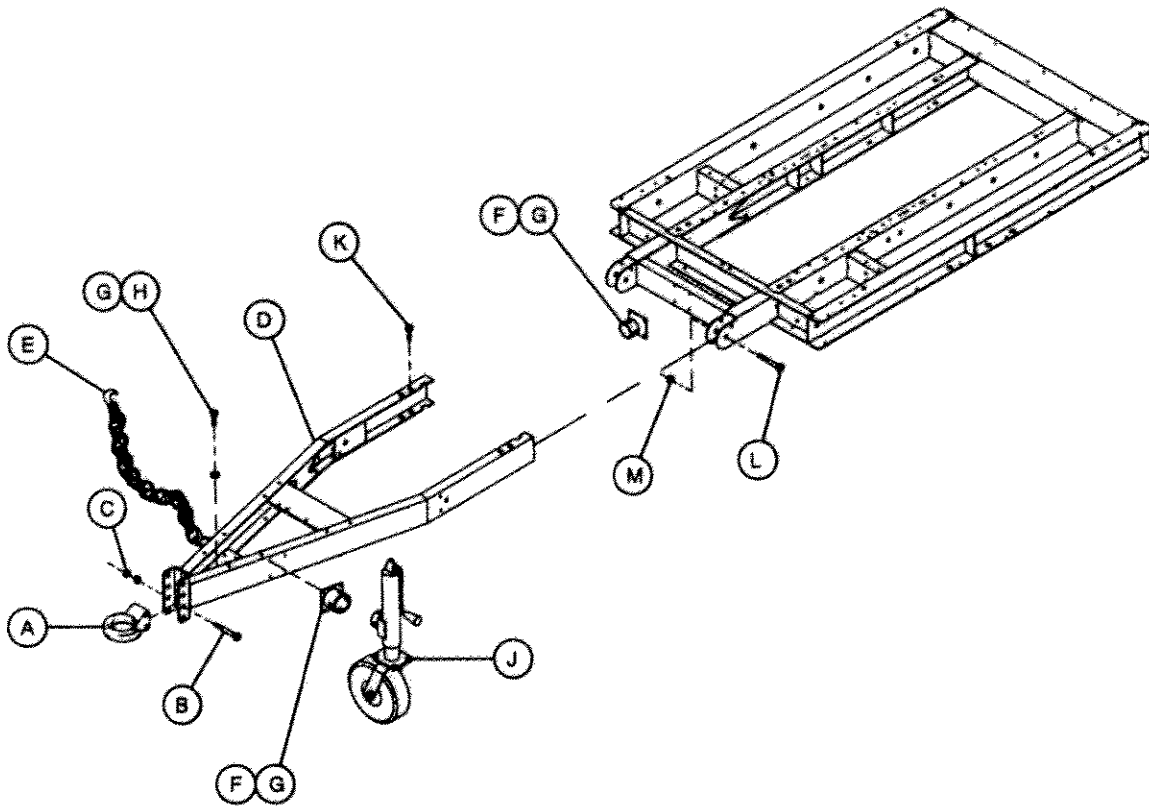

Item	CPN	Qty	Description	Item	CPN	Qty	Description
A	35605187	1	EYE, PINTEL	G	35279025	10	SCREW, TAPPING M08-1.25 X 20
B	35376094	2	SCREW, HEX 16-2.0 X 120	H	95934907	2	WASHER, FLAT
C	98701750	4	NUT, HEX M16-2.0	J	36888709	1	JACK ASM.
D	36886364	1	DRAWBAR	K	36879492	4	SCREW, HEX FLG M12-1.75 X 25
E	22144521	2	CHAIN & HOOK ASM.	L	35290113	2	SCREW, HEX M16-2.0 X 75
F	36796068	2	TUBE, JACK MTG.	M	96704630	2	NUT, NYLOC M16-2.0



# JACK ASSEMBLY

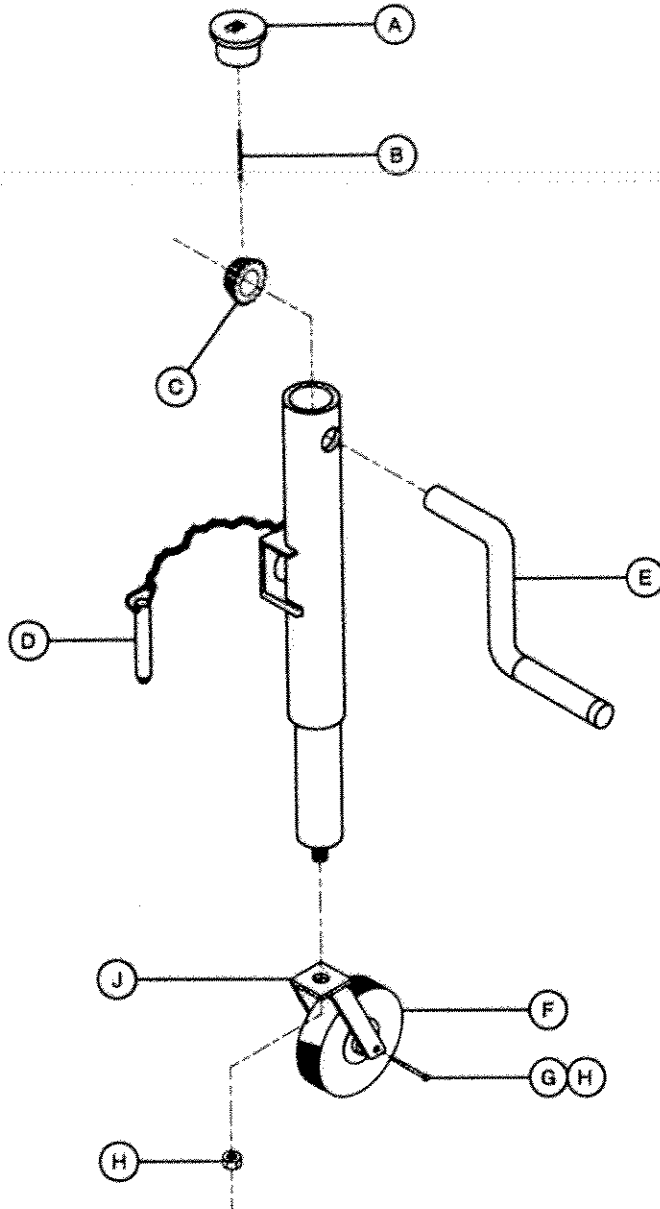

JACK ASSEMBLY 36888709

Item	CPN	Qty	Description
A	35392521	1	CAP
B	35392539	1	PIN, ROLL
C	35392547	1	GEAR, DRIVE
D	35392554	1	PLUNGER PIN KIT
E	35392562	1	HANDLE ASSEMBLY
F	35392588	1	CASTER WHEEL
G	35392596	1	BOLT, CASTER WHEEL 1/2-13 X 3.18
H	95923348	2	NUT, HEX NYLOCK 1/2-13
J	35392570	1	YOKE, CASTER WHEEL

**RUNNING GEAR COMPLETE**

**← DRAWBAR END**

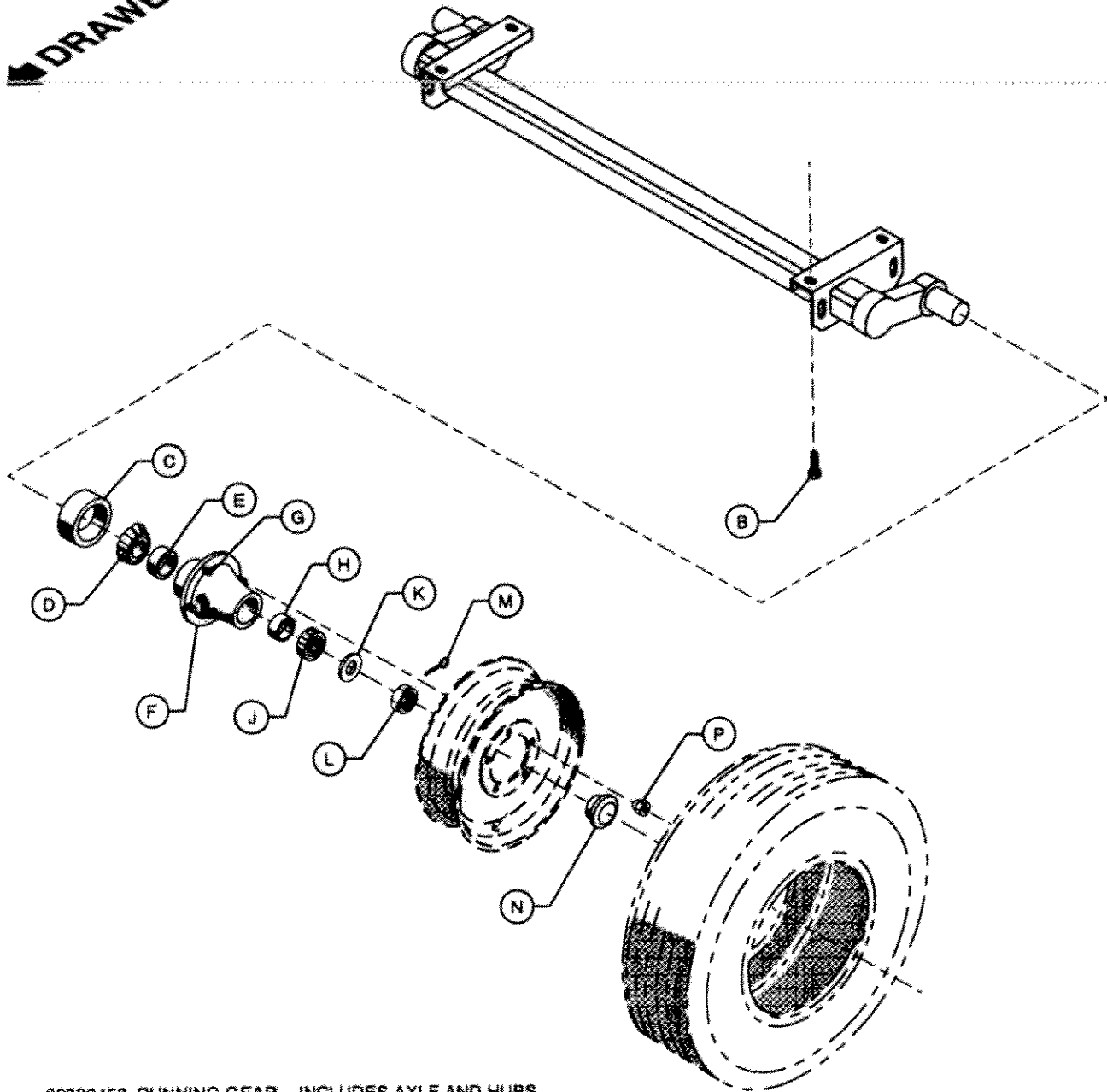

36880458 RUNNING GEAR - INCLUDES AXLE AND HUBS  
(TORSION ARMS AND AXLE NOT AVAILABLE SEPARATELY)

\* ITEMS INCLUDED IN KIT

Item	CPN	Qty	Description	Item	CPN	Qty	Description
A	35085398	*	KIT, HUB	H	35315183	2	BEARING CUP
B	36879302	4	SCREW, HEX M16-200 X 150	J	35315191	2	BEARING CONE
C	35315142	2	GREASE SEAL	K	35315209	2	SPINDLE WASHER
D	35361864	2	BEARING CONE	L	35315217	2	SPINDLE NUT
E	35361872	2	BEARING CUP	M	35315225	2	COTTER PIN
F	35361880	2	HUB	N	35315233	2	GREASE CAP
G	35361898	10	WHEEL STUD	P	35315274	10	WHEEL NUT

# 13" TIRE & WHEEL

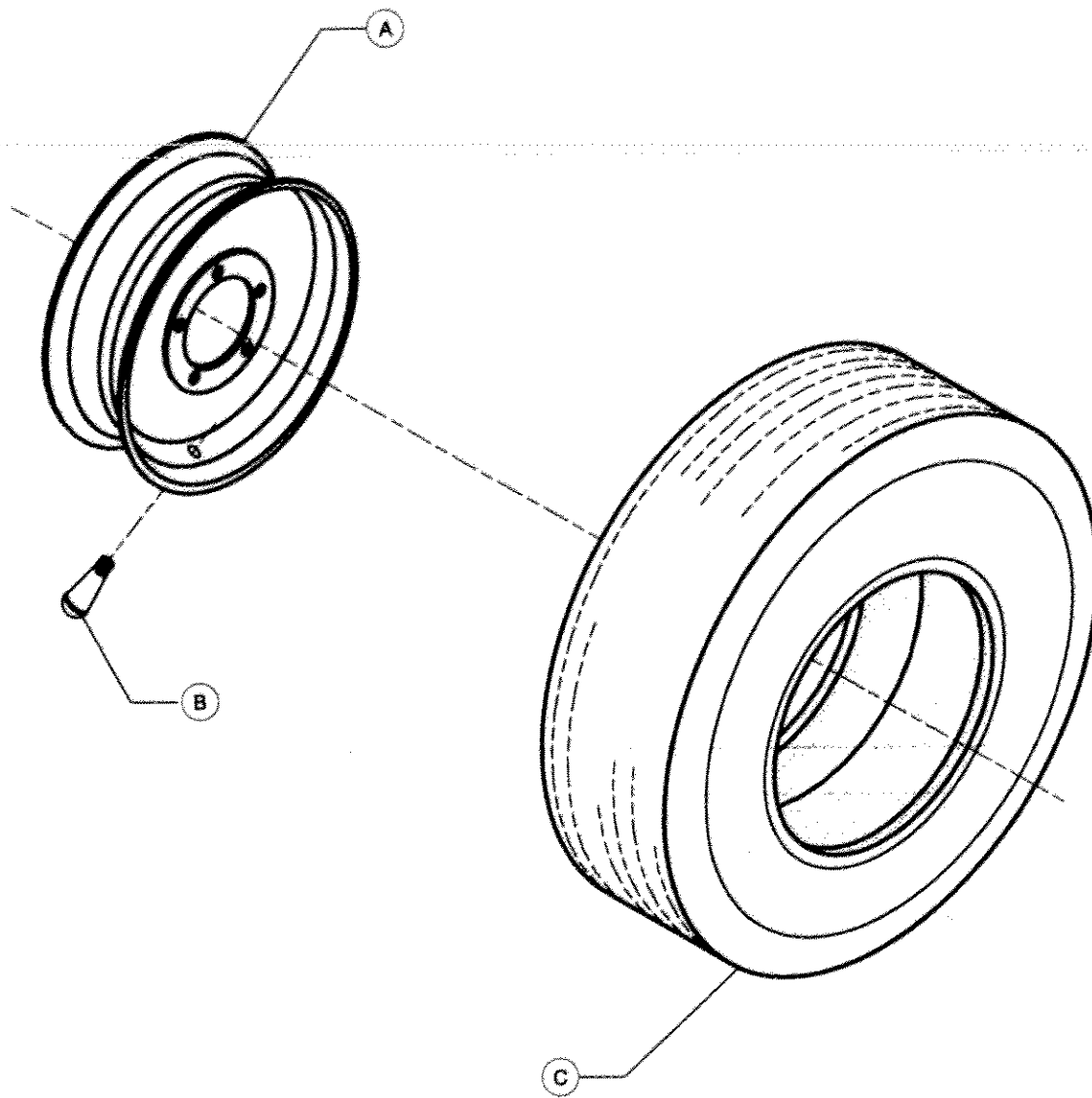

Item	CPN	Qty	Description
A	35292986	1	WHEEL, 13 X 4.50
B	35282565	1	VALVE STEM
C	22246268	1	TIRE, ST175/80D13

15" TIRE & WHEEL

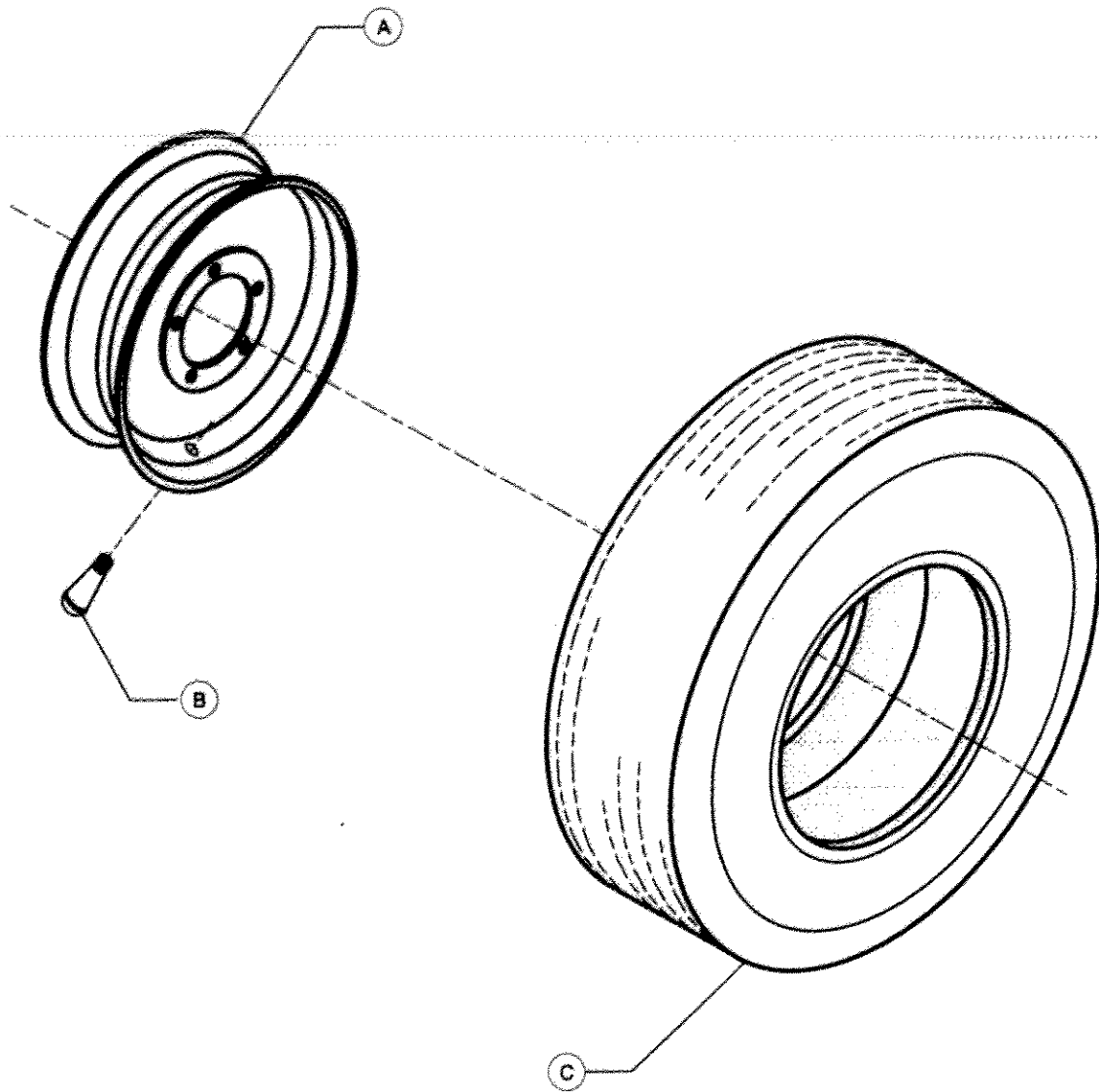

Item	CPN	Qty	Description
A	35277706	1	WHEEL, 15 X 6
B	35282565	1	VALVE STEM
C	22246276	1	TIRE, ST205/75D15

# TAIL LIGHT WIRING

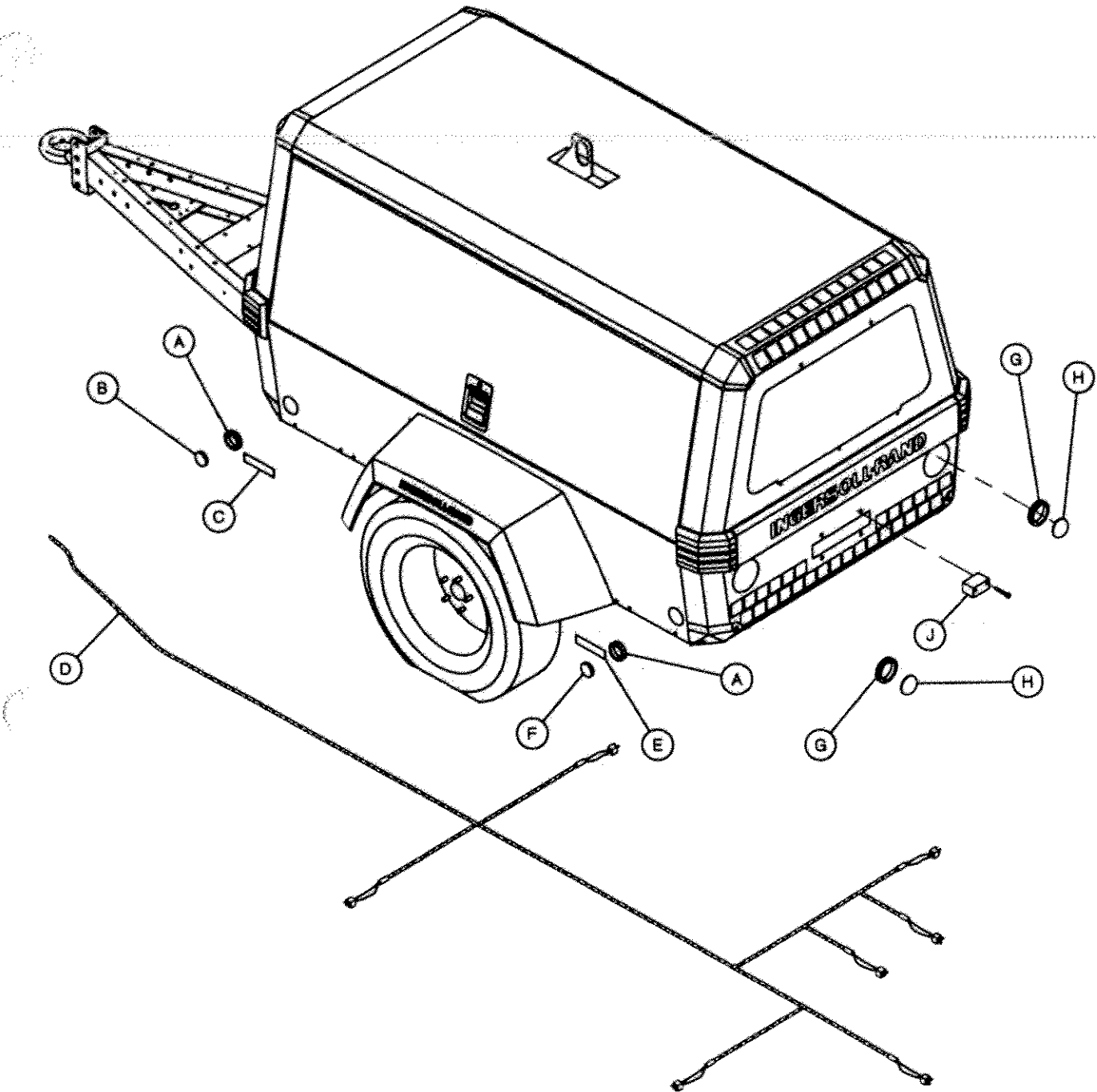

Item	CPN	Qty	Description
A	36893634	4	GROMMET, CLEARANCE LIGHT
B	35387051	2	LIGHT, AMBER CLEARANCE
C	36894616	2	REFLECTOR, AMBER
D	36893196	1	HARNES, 2-LIGHT
E	36894608	2	REFLECTOR, RED
F	35367044	2	LIGHT, RED CLEARANCE
G	36787968	2	GROMMET, TAIL LIGHT
H	36788081	2	LIGHT, COMBO TAIL
J	54726468	1	LIGHT, LICENSE

# ENGINE and EXHAUST COMPLETE

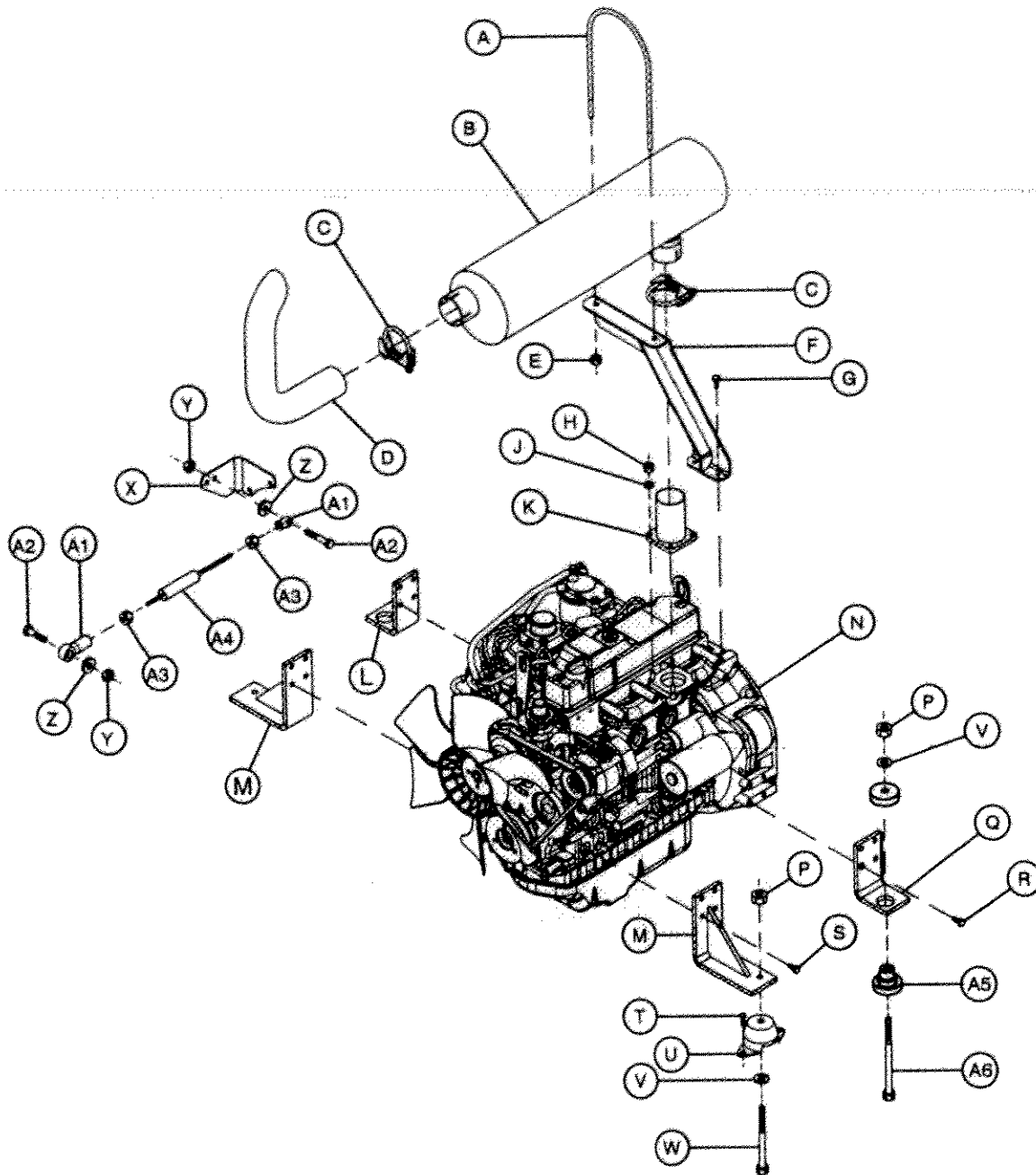

Item	CPN	Qty	Description	Item	CPN	Qty	Description
A	368893287	1	U-BOLT	R	36880995	8	SCREW, HEX FLG M10-1.5 X 30
B	22179246	1	MUFFLER	S	96702279	8	SCREW, HEX M10-1.5 X 20
C	35209048	2	CLAMP, SADDLE	T	35279025	4	SCREW, TAPPING M08-1.25 X 20
D	22242457	1	PIPE, TAIL	U	54429303	2	ISOLATOR
E	95923322	2	NUT, HEX LOCK 3/8-16	V	54429295	4	WASHER, SNUBBING
F	22179378	1	BRACKET, MUFFLER	W	96739958	4	SCREW, HEX M12-1.75 X 70
G	96702048	2	SCREW, HEX M08-1.25 X 16	X	22205447	1	BRACKET, SPEED CONTROL
H	96735543	4	NUT, HEX M08-1.25	Y	36769032	2	NUT, HEX FLANGE M06-1.0
J	95934998	4	WASHER, FLAT	Z	95935029	2	WASHER, FLAT
K	22178974	1	PIPE, EXHAUST	A1	35328467	2	BEARING, ROD END 5/16-24
L	22205686	1	BRACKET, ENG. MT. REAR STSD	A2	96701461	2	SCREW, HEX M06-1.0 X 25
M	22197701	2	BRACKET, ENG. MT. FRONT STSD	A3	95935086	2	NUT, 5/16-24
N	22208516	1	ENGINE, 4IR18N	A4	35592435	1	CYLINDER, AIR
P	35304047	4	NUT, NYLOC M12-1.75	A5	54439082	2	ISOLATOR MOUNT
Q	22197719	1	BRACKET, ENG. MT. REAR CRBSD	A6	96740782	2	SCREW, HEX M12-1.75 X 80

# ENGINE OVERHAUL GASKET SET

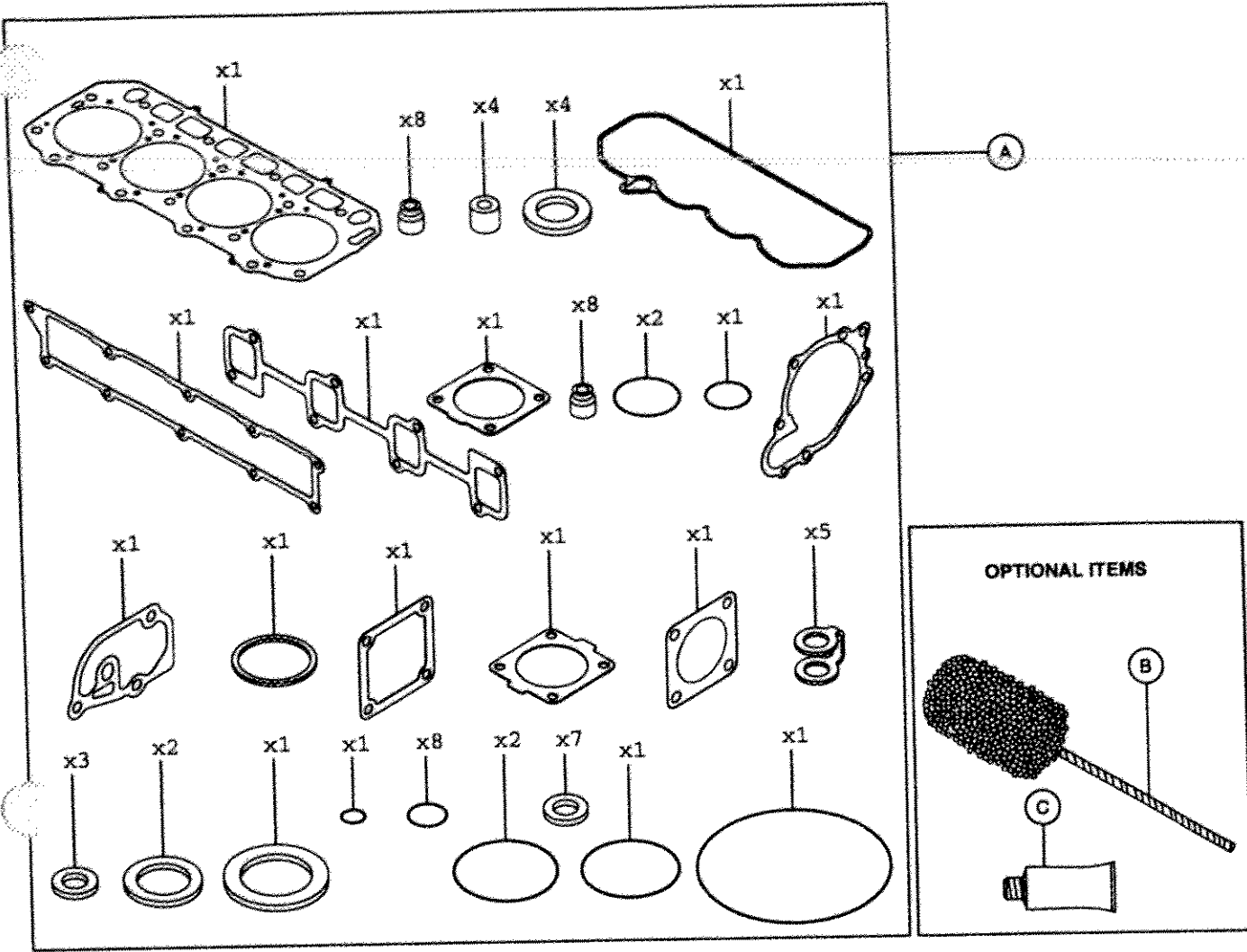

Item	CPN	Description
A	15894850	GASKET SET
B	15895188	HOAN, CYLINDER
C	15899354	GASKET, LIQUID

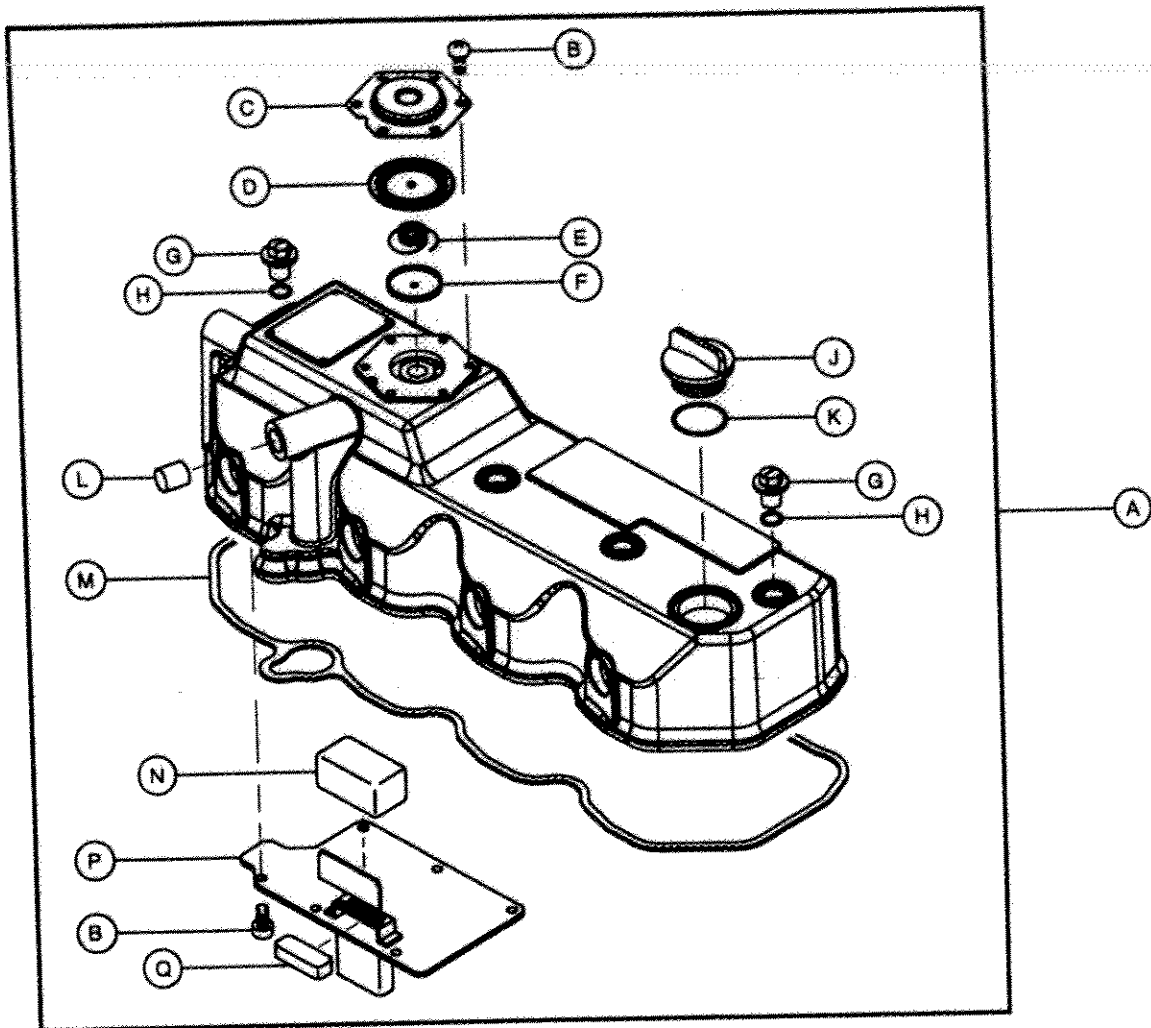

Item	CPN	Qty	Description	Item	CPN	Qty	Description
A	15896081	1	VALVE COVER ASM.	J	15898182	1	CAP, OIL FILLER
B	15898919	8	SCREW 5X10,TAPPING	K	15898984	1	O-RING 1A P-32.0
C	15896129	1	PLATE, BREATHER	L	15896152	1	PLUG
D	15896103	1	DIAPHRAGM, BREATHER	M	15896145	1	GASKET, VALVE COVER
E	15896137	1	SPRING, DIAPHRAGM	N	15896095	1	BAFFLE
F	15896111	1	CENTER PLATE	P	15896079	1	PLATE, BAFFLE
G	15898216	4	KNOB	Q	15896087	1	BAFFLE
H	15898968	4	O-RING 1A P 12.0				



# ROCKER ARM ASM.

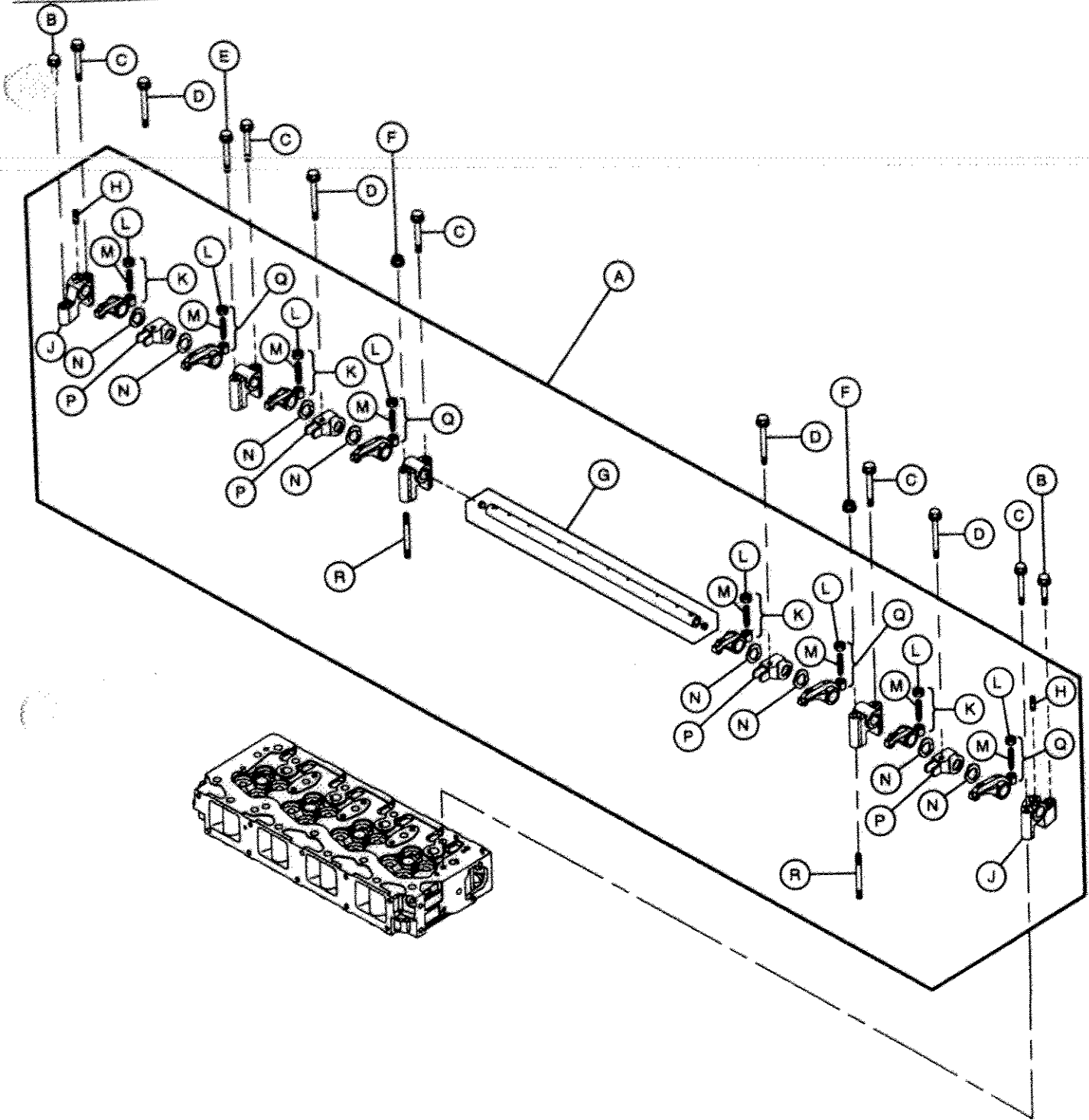

Item	CPN	Qty	Description	Item	CPN	Qty	Description
A	15895956	1	SHAFT ASSY, ROCKER	J	15895980	2	SUPPORT, ROCKER SHAFT END
B	15899115	2	BOLT M 8X 40 PLATED	K	15896012	4	ARM ASSY, ROCKER
C	15895105	5	BOLT M 8X 60 PLATED	L	15898463	8	NUT, HEX M8-1.0
D	15896053	4	BOLT M 8X 75 PLATED	M	15898448	6	SCREW, VALVE
E	15896046	1	BOLT M 8X 65 PLATED	N	15895998	8	WASHER, WAVE
F	15899198	2	NUT, HEX FLANGE M08-1.25	P	15896020	4	RETAINER, F.I. VALVE
G	15895964	1	SHAFT, ROCKER ARM	Q	15896004	4	ARM ASSY, ROCKER
H	15896038	2	STUD M 8X 22 PLATED	R	15895949	2	STUD 8X80

# CYLINDER HEAD ASM.

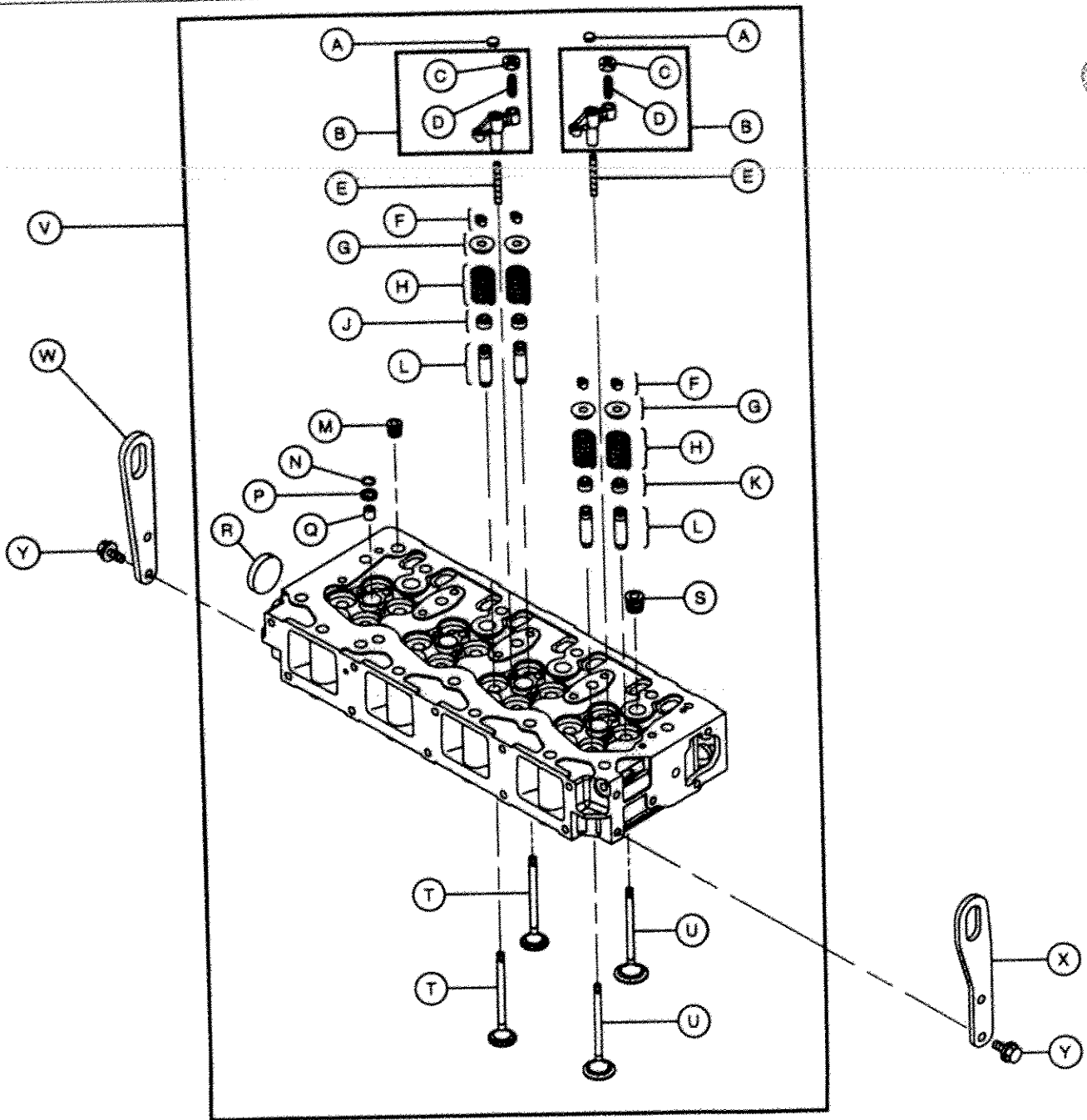

Item	CPN	Qty	Description	Item	CPN	Qty	Description
A	15895931	8	SEAT, VALVE BRIDGE	N	15898968	4	O-RING 1A P 12.0
B	15895907	8	BRIDGE ASSY, VALVE	P	15897168	4	SEAT, NOZZLE
C	15898463	8	NUT, HEX M8-1.0	Q	15897416	4	PROTECTOR, NOZZLE
D	15895915	8	SCREW, VALVE BRIDGE	R	15899248	1	PLUG 40
E	15895857	8	GUIDE, VALVE BRIDGE	S	15898943	4	PLUG NPT 3/8
F	15895923	16	COTTER ASSY	T	15895873	8	VALVE, EXHAUST
G	15895899	16	RETAINER, SPRING	U	15895865	8	VALVE, INTAKE
H	15895881	16	SPRING, VALVE	V	15895832	1	HEAD ASSY, CYLINDER
J	15898281	8	SEAL, EXHAUST VALVE STEM	W	15895824	1	LIFTER, ENGINE
K	15898208	8	SEAL, INTAKE VALVE STEM	X	15895816	1	LIFTER, ENGINE
L	15895840	16	GUIDE, VALVE	Y	15899065	4	BOLT M 8X 16 PLATED
M	15895097	1	PLUG NPT 1/4				

# CYLINDER BLOCK ASM.

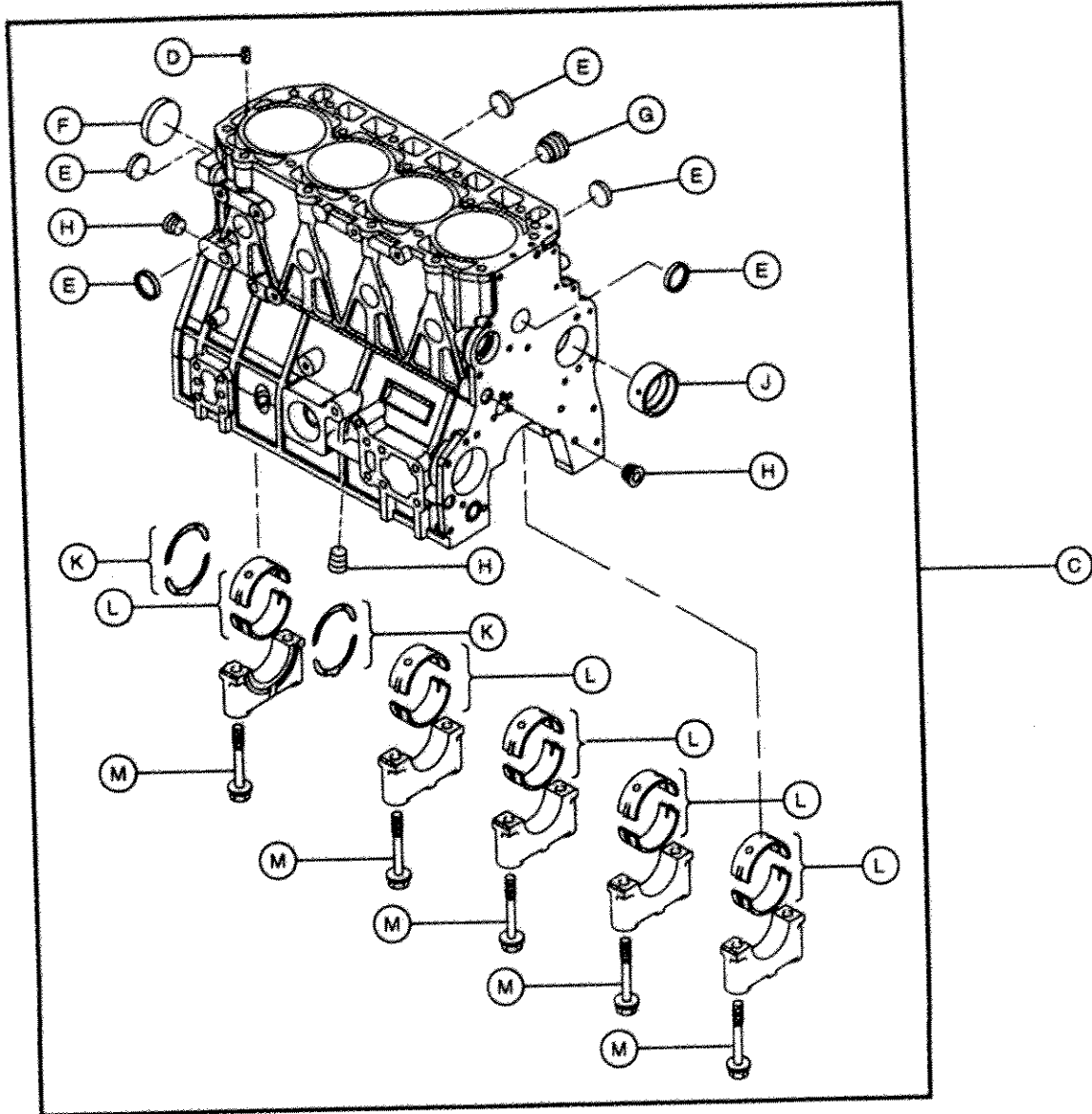
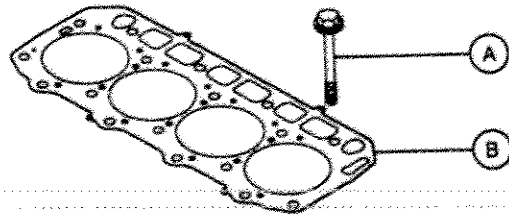

Item	CPN	Qty	Description	Item	CPN	Qty	Description
A	15895600	1	GASKET, CYL. HEAD	H	15898943	3	PLUG NPT 3/8
B	15899875	18	BOLT, CYL. HEAD	J	15895568	1	BUSH, CAMSHAFT
C	15895535	1	BLOCK ASSY, CYLINDER	K	15895584	2	BEARING ASSY, THRUST
D	15898893	2	SPRING PIN 6X12		15895626	2	BEARING ASSY, THRUST .25 OVERSIZE
E	15899230	8	PLUG 30	L	15895576	5	BEARING ASSY, MAIN
F	15895543	1	PLUG 55		15895618	5	BEARING ASSY, MAIN UNDERSIZE=.025
G	15895030	1	PLUG	M	15895550	10	BOLT, METAL CAP

# OIL PAN ASM. & SUMP TUBE

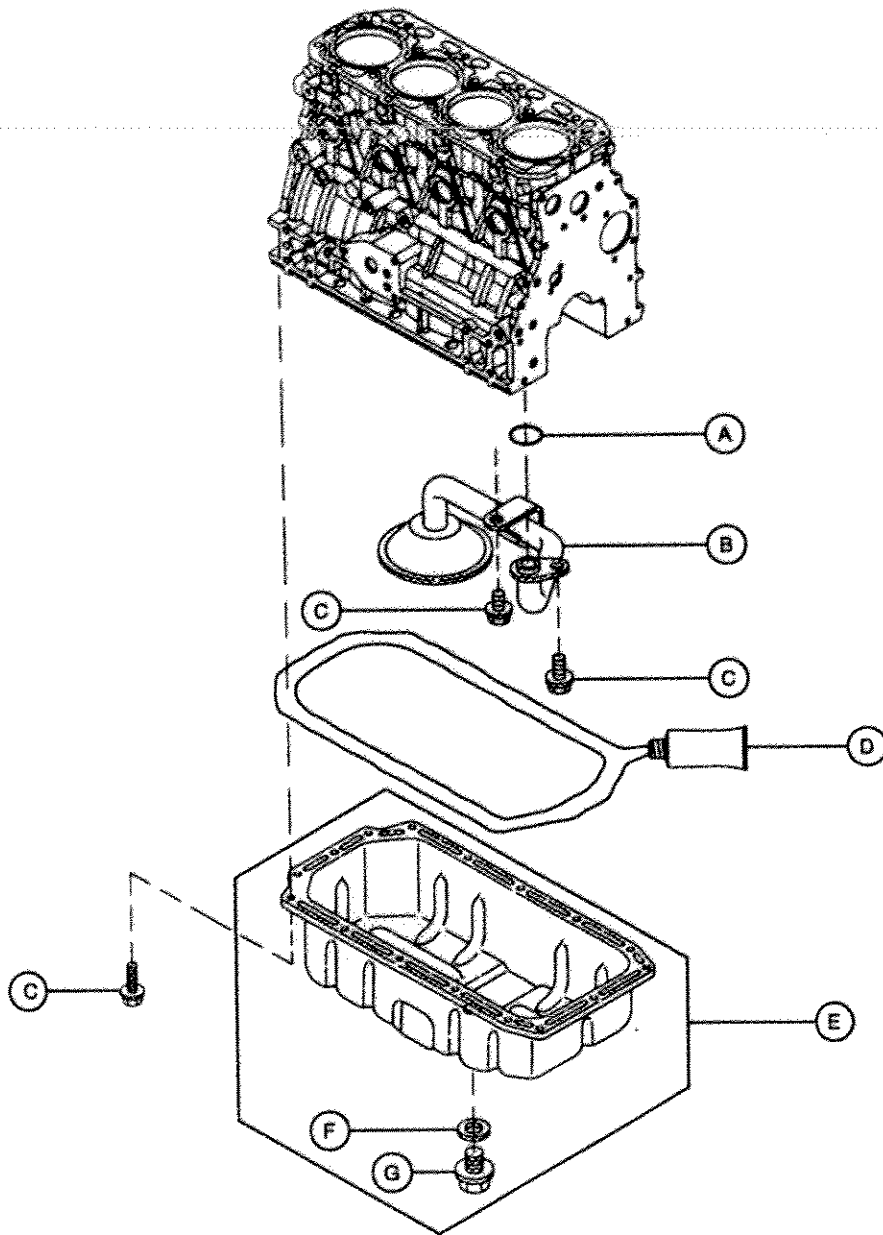

Item	CPN	Qty	Description
A	15895709	1	O-RING P20
B	15896558	1	PIPE ASSY, LUBRICATION OIL
C	15899040	18	BOLT M 8 X 12 PLATED
D	15898354	AR	GASKET, LIQUID
E	15895806	1	PAN ASSY, OIL
F	15897184	1	PLUG, M22 DRAIN
G	15898877	1	WASHER, 22S SEAL

# FLYWHEEL

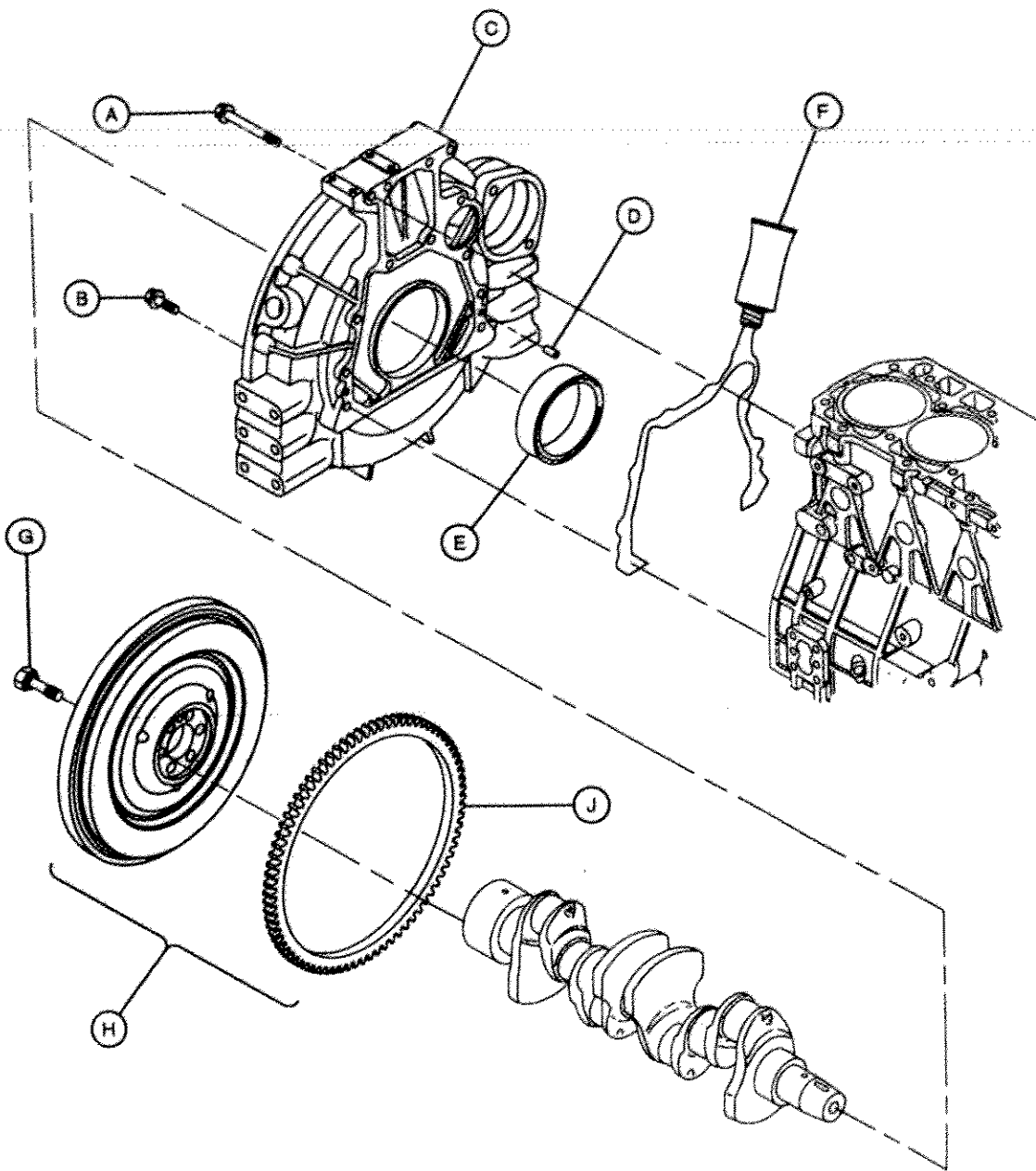

Item	CPN	Qty	Description	Item	CPN	Qty	Description
A	15894934	4	BOLT M10X 70 PLATED	F	15899354	AR	GASKET, LIQUID
B	15894926	9	BOLT M10X 35 PLATED	G	15896392	6	BOLT, FLYWHEEL
C	15895782	1	COVER ASSY, FLYWHEEL	H	15896400	1	FLYWHEEL ASSY
D	15898364	2	DOWEL PIN 8X16	J	15896418	1	GEAR, RING
E	15895790	1	SEAL, OIL				

# CAMSHAFT & IDLE GEARS

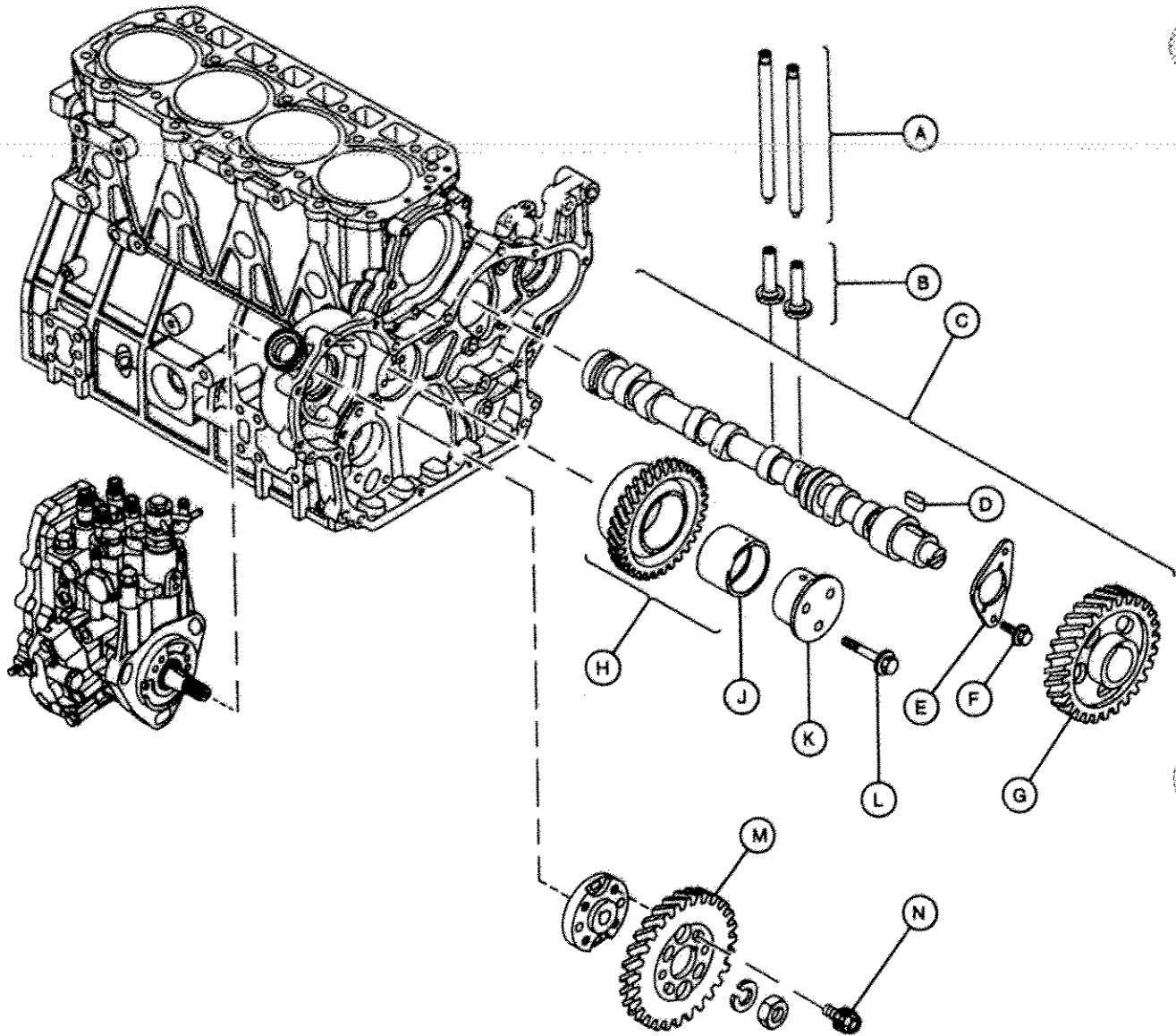

Item	CPN	Qty	Description
A	15896244	8	ROD, PUSH
B	15898489	8	TAPPET
C	15896251	1	CAMSHAFT ASSY
D	15898901	1	KEY, 7X.14
E	15898422	1	METAL, CAMSHAFT THRUST
F	15899065	2	BOLT M 8X 16 PLATED
G	15896269	1	GEAR, CAMSHAFT
H	15896285	1	GEAR ASSY, IDLE
J	15896293	1	BUSHING, IDLE GEAR
K	15896277	1	SHAFT, IDLE GEAR
L	15899149	3	BOLT M 8X 55 PLATED
M	15896319	1	GEAR, FUEL INJECTION PUMP
N	15896301	4	BOLT, FI-PUMP

# CRANKSHAFT & PISTONS

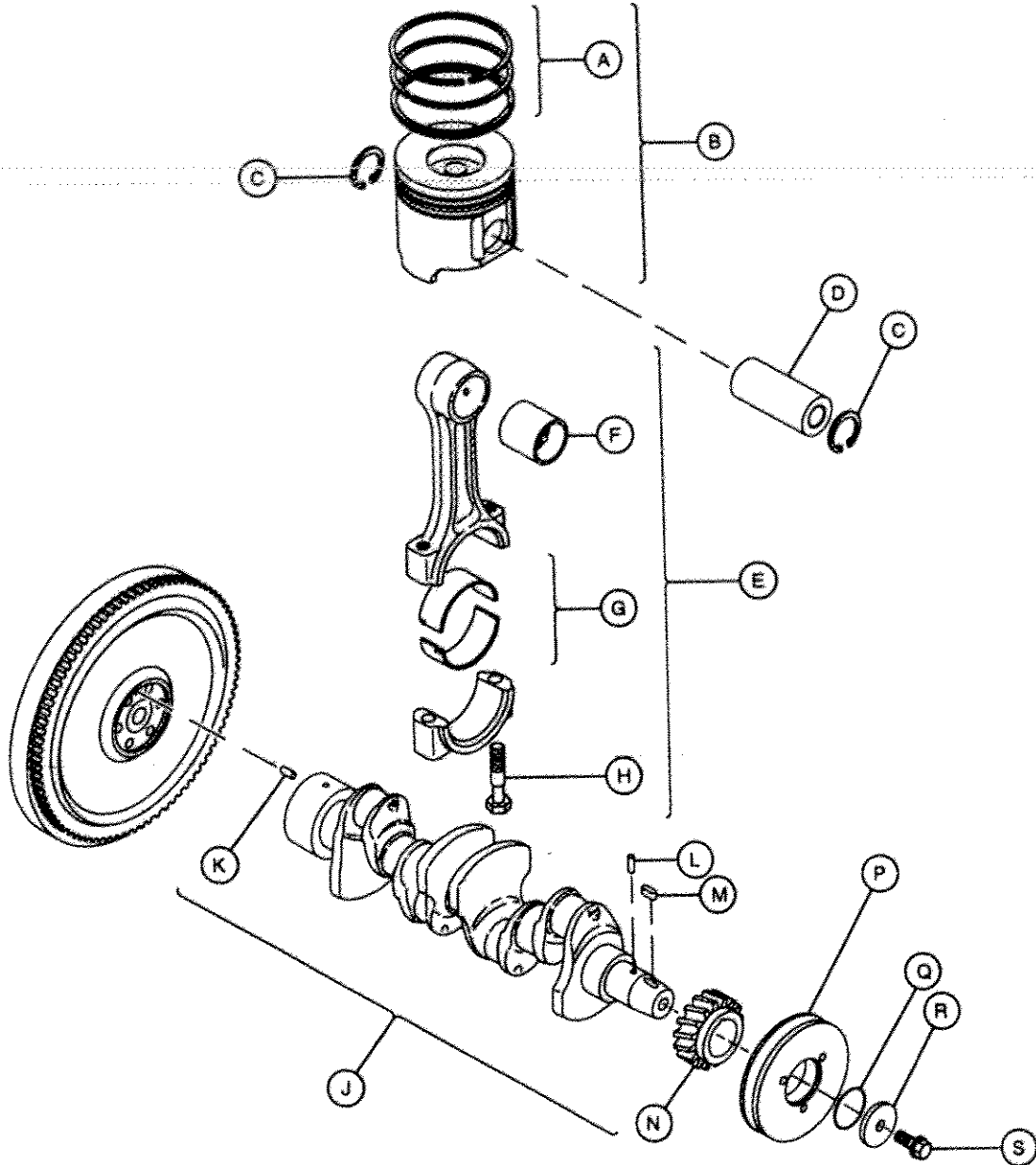

Item	CPN	Qty	Description	Item	CPN	Qty	Description
A	15896442	4	RING SET, STD. PISTON	H	15896491	8	BOLT, CONNECTING ROD
	15896533	4	RING SET, PISTON O.S=0.25	J	15896327	1	CRANKSHAFT ASSY
B	15896434	4	STD. PISTON ASSY	K	15896350	1	DOWEL PIN 10 X 22
	15896525	4	PISTON ASSY OS=.25	L	15896343	1	DOWEL PIN
C	15896467	8	RING, PISTON RETAINING 30	M	15898901	1	KEY 7 X 14
D	15896459	4	PIN, PISTON	N	15896335	1	GEAR, CRANKSHAFT
E	15896475	4	ROD ASSY, CONNECTING	P	15896376	1	V-PULLEY, CRANKSHAFT
F	15896483	4	BUSH, PISTON PIN	Q	15896426	1	O-RING 1A S-53.0
G	15896509	4	BEARING, STD. PISTON ROD	R	15896368	1	WASHER
	15896517	4	BEARING, PISTON ROD U.S=0.25	S	15896384	1	BOLT, V-PULLEY

# TIMING GEAR HOUSING

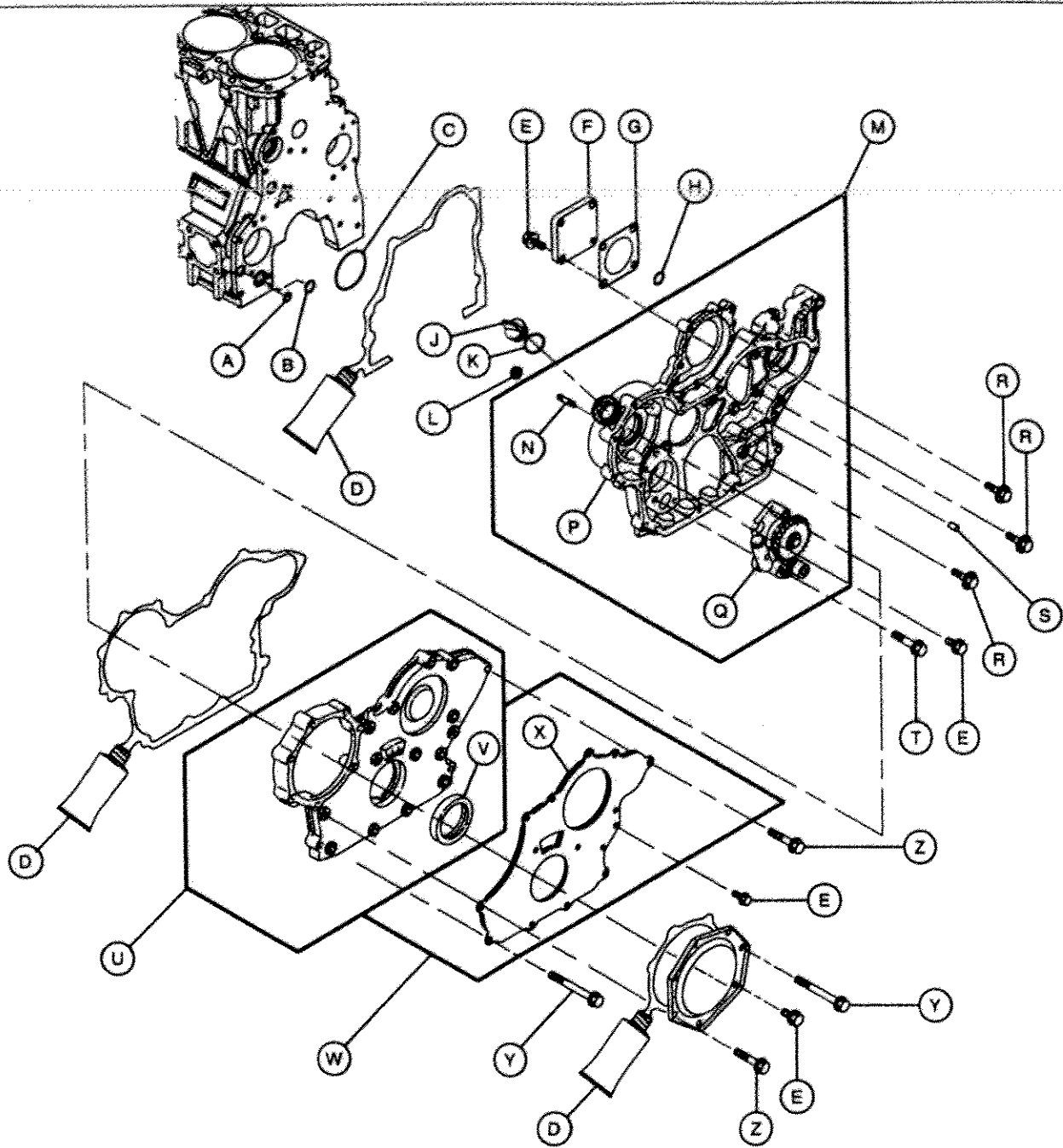

Item	CPN	Qty	Description	Item	CPN	Qty	Description
A	15895717	1	O-RING P14	N	15895683	4	STUD M10X 32
B	15895709	1	O-RING P20	P	15895675	1	HOUSING, GEAR
C	15895741	1	PACKING	Q	15895691	1	PUMP ASM., OIL
D	15899354	AR	GASKET, LIQUID	R	15899073	7	BOLT M 8X 20 PLATED
E	15899065	9	BOLT M 8X 16 PLATED	S	15898364	4	DOWEL PIN 8X16
F	15898232	1	COVER, FUEL PUMP	T	15899123	4	COVER, BLINDBOLT M 8X 45 PLATED
G	15895758	1	GASKET, FUEL PUMP COVER	U	15895634	1	HOUSING ASM., TIMING GEAR
H	15895733	1	O-RING 1A P-7.0	V	15895642	1	SEAL, OIL
J	15898182	1	CAP, OIL FILLER	W	15895766	1	COVER ASM., TIMING
K	15898984	1	O-RING 1A P-32.0	X	15895774	1	SPONGE
L	15899206	4	NUT, HEX FALNGE M10-1.5	Y	15895725	7	BOLT M 8X 70 PLATED
M	15895667	1	CASE ASSY, GEAR	Z	15899115	10	BOLT M 8X 40 PLATED



# INTAKE MANIFOLD

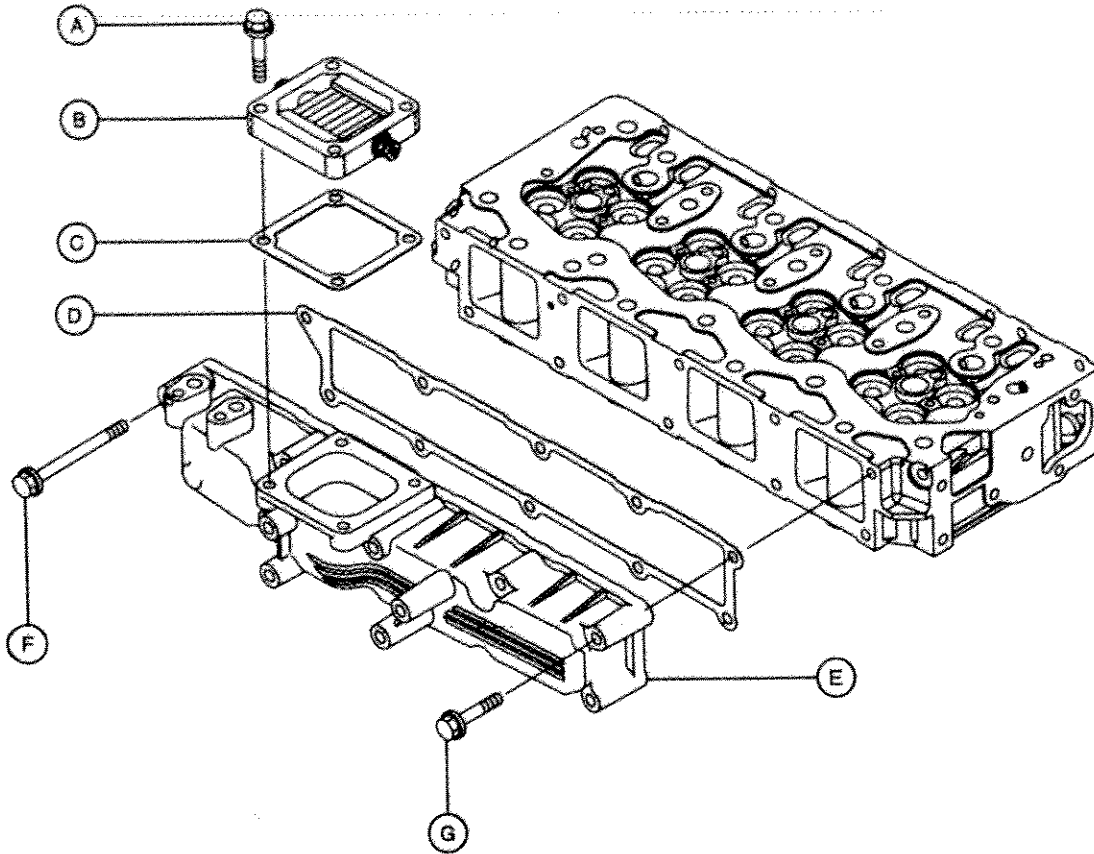

Item	CPN	Qty	Description
A	15899107	4	BOLT M 8 X 35 PLATED
B	15896210	1	HEATER, AIR
C	15896202	1	GASKET, INTAKE AIR HEATER
D	15896178	1	GASKET, INTAKE MANIFOLD
E	15896160	1	MANIFOLD, INTAKE
F	15899149	9	BOLT M 8 X 55 PLATED
G	15896194	1	BOLT M 8 X 55 PLATED

# EXHAUST MANIFLOD

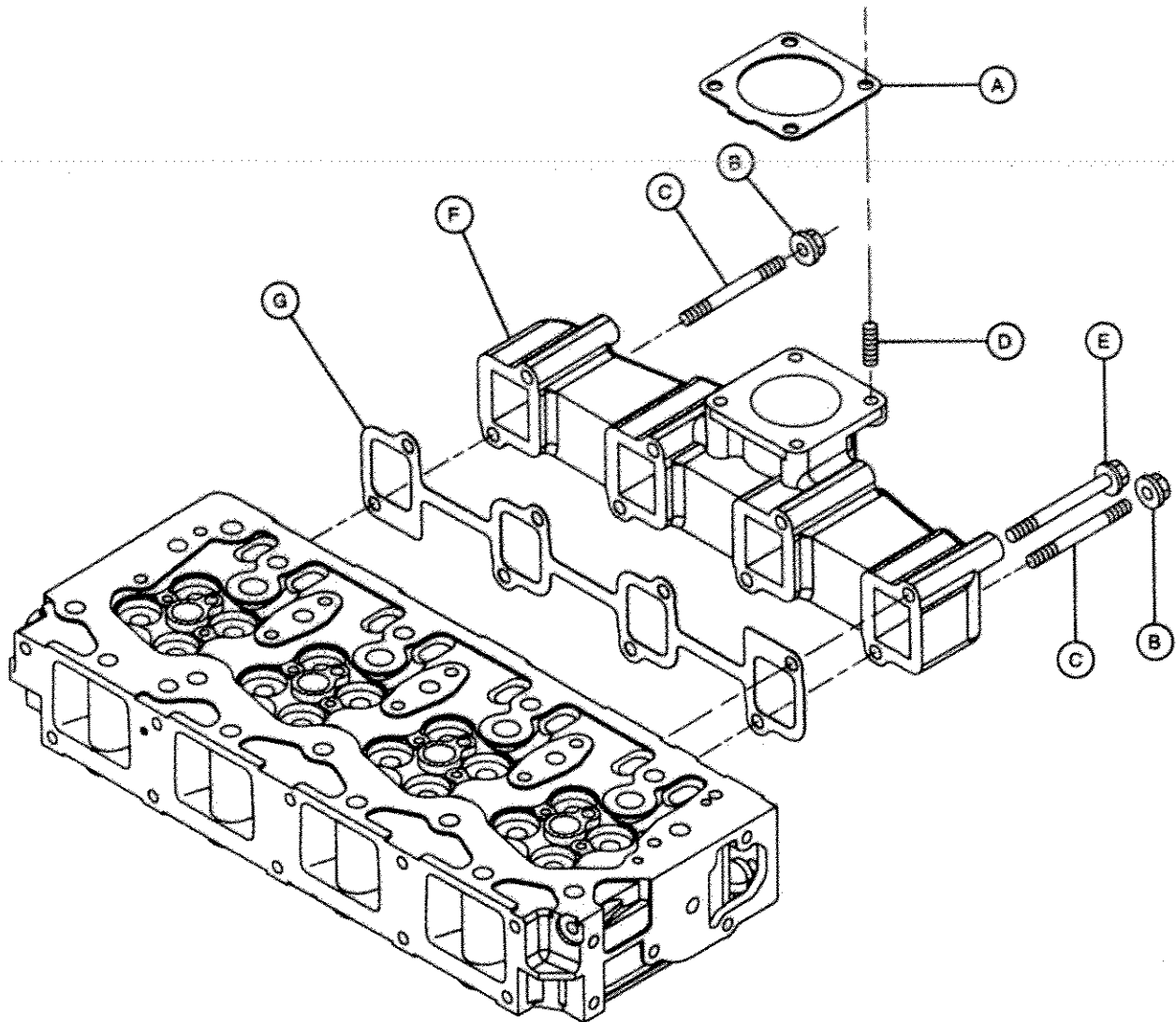

Item	CPN	Qty	Description
A	15895329	1	GASKET, EXHAUST
B	15899198	2	NUT, HEX FLANGE M08-1.25
C	15899420	2	STUD BOLT M 8X 80
D	15897069	4	BOLT M 8X 22
E	15899438	6	BOLT 8X80
F	15896228	1	MANIFOLD, EXHAUST
G	15896236	1	GASKET, EXH.MANIFOLD

# WATER PUMP & THERMOSTAT

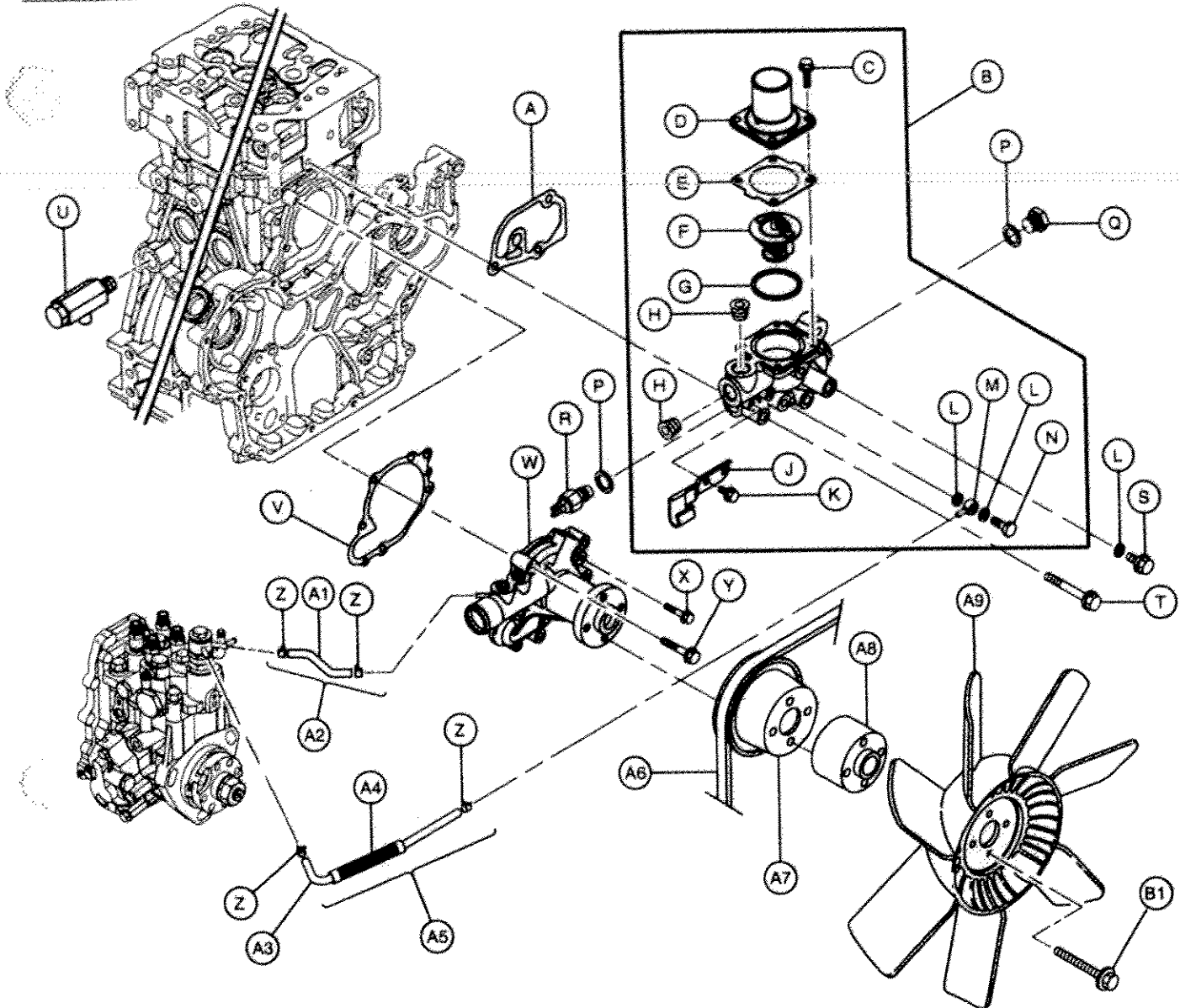

Item	CPN	Qty	Description	Item	CPN	Qty	Description
A	15896764	1	GASKET, THERMOSTAT CASE	T	15895105	3	BOLT M 8X 60 PLATED
B	15896665	1	CASE ASSY, THERMOSTAT	U	15896822	1	COCK ASSY 1/4
C	15899032	4	BOLT M 6 X 20 PLATED	V	15896590	1	GASKET, WATER PUMP
D	15896673	1	COVER, THERMOSTAT	W	15896582	2	PUMP ASSY, WATER
E	15896681	1	GASKET, THERMOSTAT COVER	X	15896608	2	BOLT M 6X 30 PLATED
F	15896715	1	THERMOSTAT	Y	15899149	5	BOLT M 8X 55 PLATED
G	15896699	1	GASKET, THERMOSTAT	Z	15898265	4	CLAMP 9
H	15896749	2	PLUG, 3/8 NPT STEEL	A1	15896814	1	PIPE B, COOLING WATER
J	15896707	1	PIPE ASSY, INJECTION	A2	15896806	1	HOSE B ASSY, WATER
K	15896756	2	BOLT M 6 X 12 PLATED	A3	15896780	1	PIPE A, COOLING WATER
L	15898927	3	GASKET 8	A4	15896798	1	PROTECTOR, PIPE 10.7
M	15896731	1	JOINT 4- 8	A5	15896772	1	HOSE A ASSY, WATER
N	15896723	1	BOLT, PIPE JOINT	A6	15896624	1	V-BELT
P	15898240	2	GASKET 16	A7	15896616	1	V-PULLEY
Q	15898109	1	PLUG M16	A8	15896640	1	SPACER, FAN
R	35327691	1	SWITCH, TEMPERATURE <i>1589 805</i>	A9	22126429	1	FAN
S	15899040	1	BOLT M 8X 12 PLATED	B1	15896657	4	BOLT M10X 65 PLATED

# INJECTION PUMP AND FUEL LINES

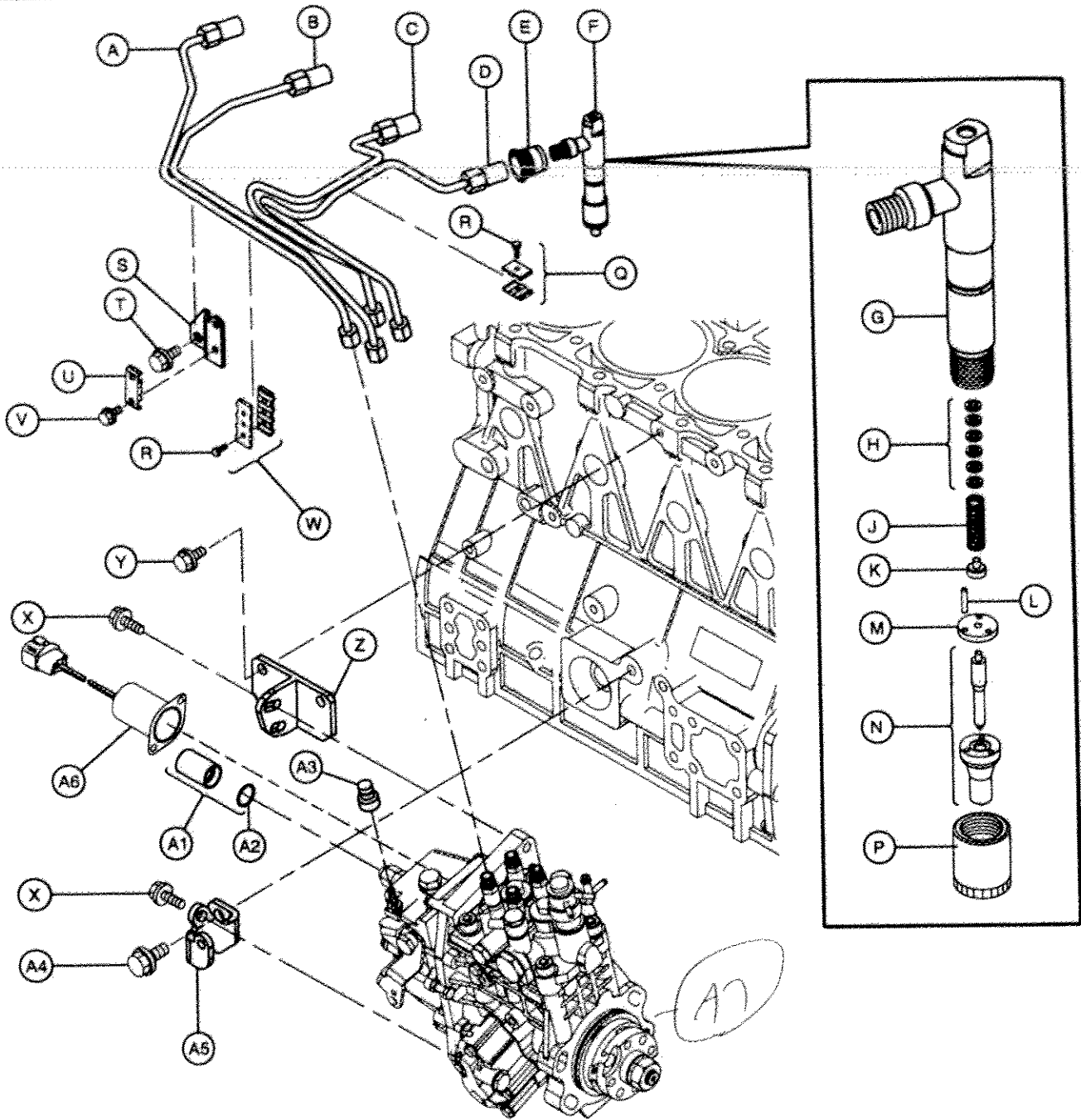

Item	CPN	Qty	Description	Item	CPN	Qty	Description
A	15896921	1	PIPE ASSY, #1 INJECTION	R	15898554	3	BOLT, HEX SOCKET M4X14
B	15896939	1	PIPE ASSY, #2 INJECTION	S	15896913	1	BRACKET, 2 TUBE SUPPORT
C	15896947	1	PIPE ASSY, #3 INJECTION	T	15894660	1	BOLT M 8X 18 PLATED
D	15896954	1	PIPE ASSY, #4 INJECTION	U	15896905	2	RETAINER, 2 INJECTOR PIPE
E	15896897	4	SEAL, PIPE	V	15899024	2	BOLT M 6X 16 PLATED
F	15896863	4	VALVE ASSY, FUEL INJECTOR	W	15895428	1	RETAINER, 4 INJECTOR PIPE
G	15896889	4	HOLDER ASSY, NOZZLE	X	15896830	3	BOLT M 8X 22 PLATED
H	15897051	4	SHIM PACK	Y	15899065	2	BOLT M 8X 16 PLATED
J	15897010	4	SPRING, NOZZLE	Z	15894868	1	RETAINER, INJECTOR PUMP
K	15897028	4	SEAT, NOZZLE SPRING	A1	15898588	1	CASE ASSY
L	15897044	4	PIN	A2	15898976	1	O-RING 1A P-15.0
M	15897036	4	PLATE, STOP	A3	15898855	1	CAP, HIGH-IDLE
N	15896871	4	NOZZLE ASM.	A4	15896848	1	BOLT M10X 20 PLATED
P	15897002	4	NUT, NOZZLE CASE	A5	15894876	1	SUPPORT, INJECTION THROTTLE
Q	15897093	1	RETAINER ASM., 2 TUBE	A6	22226393	1	SOLENOID, ENGINE STOP

47 15894884 Injection

# FUEL FILTER

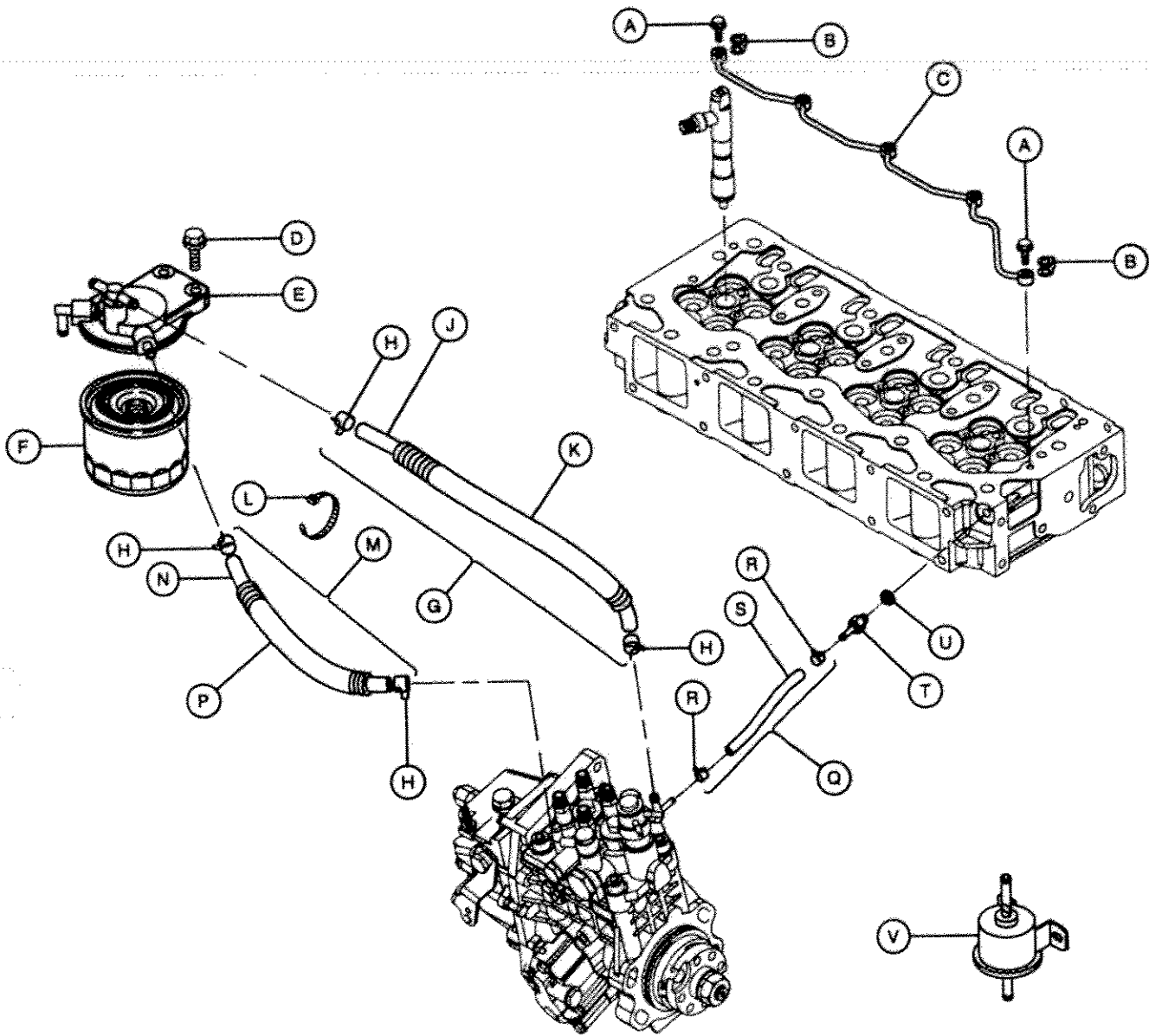

Item	CPN	Qty	Description	Item	CPN	Qty	Description
A	15894744	5	JOINT BOLT M6	L	15894777	1	CLAMP 140
B	15894751	5	PACKING, FUEL RETURN	M	15894702	1	PIPE ASSY, FUEL
C	15894736	1	PIPE ASSY, FUEL RETURN	N	15894728	1	PIPE, FUEL OIL
D	15899099	2	BOLT M 8X 30 PLATED	P	15894710	1	TUBE
E	15898349	1	HEAD, FUEL FILTER	Q	15898695	1	PIPE, FUEL RETURN
F	22226369	1	FILTER, FUEL	R	15898265	2	CLAMP 9
G	15894678	1	PIPE ASSY, FUEL	S	15898687	1	PIPE, FUEL RETURN
H	15898273	4	CLAMP 12	T	15894769	1	HOSE JOINT 4
J	15894694	1	PIPE, FUEL OIL	U	15898851	1	SEAL WASHER BS
K	15894686	1	PROTECTOR, FUEL PIPE	V	22226385	1	PUMP ASSY, FUEL FEED

# OIL FILTER

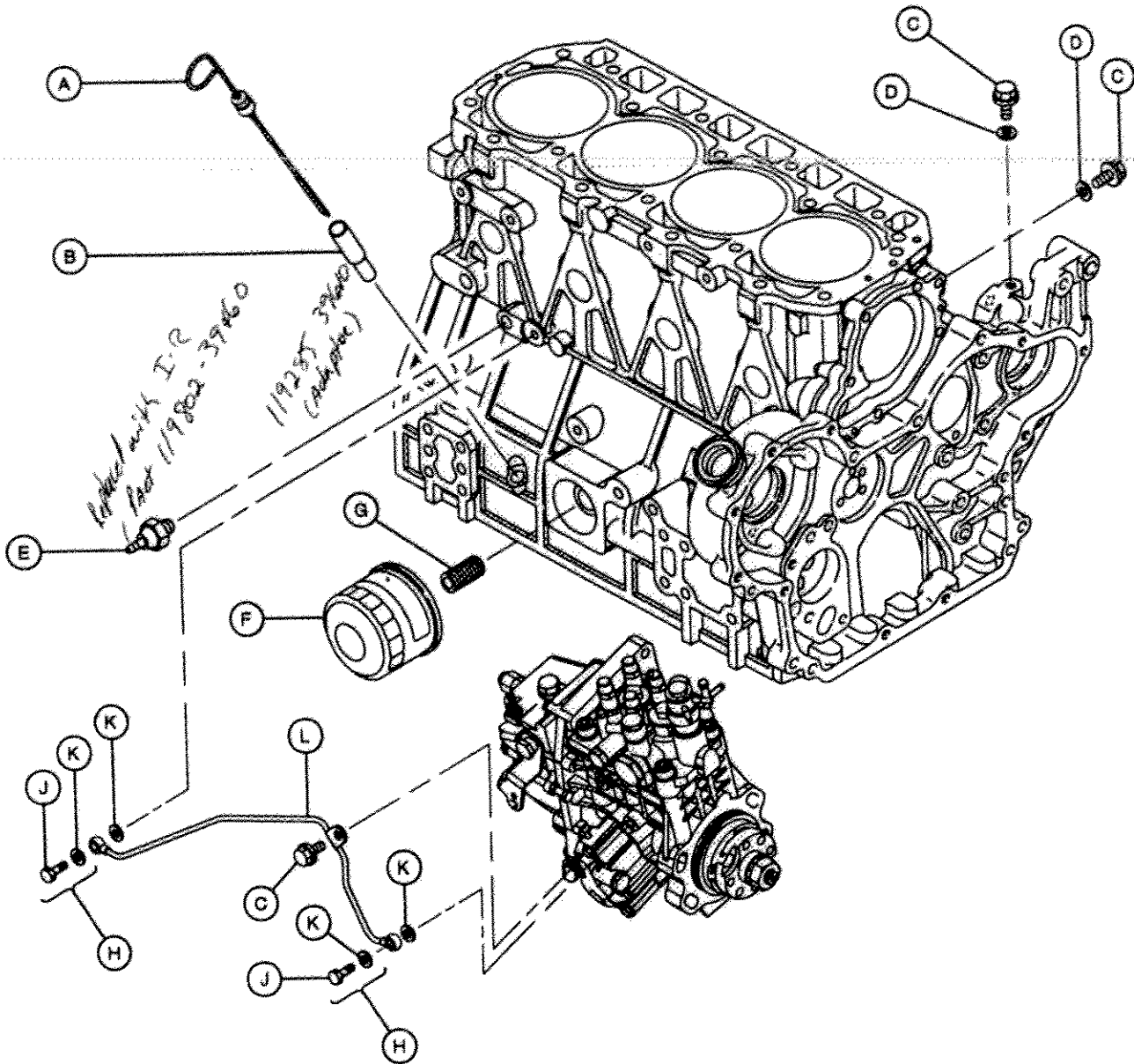

Item	CPN	Qty	Description	Item	CPN	Qty	Description
A	15896541	1	DIPSTICK	F	22226351	1	ELEMENT ASM., OIL FILTER
B	15898117	1	GUIDE, DIPSTICK	G	15896574	1	STUD, LUB.OIL FILTER
C	15899040	2	BOLT M 8X 12 PLATED	H	15898356	2	BOLT ASSY, JOINT
D	15898851	2	SEAL WASHER 8S	J	15898935	2	JOINT BOLT 3
E	15896996	1	SWITCH, OIL PRESSURE	K	15898851	4	SEAL WASHER 8S
				L	15896566	1	TUBE ASM., INJ PUMP LUBE OIL

# ELECTRICAL COMPONENTS

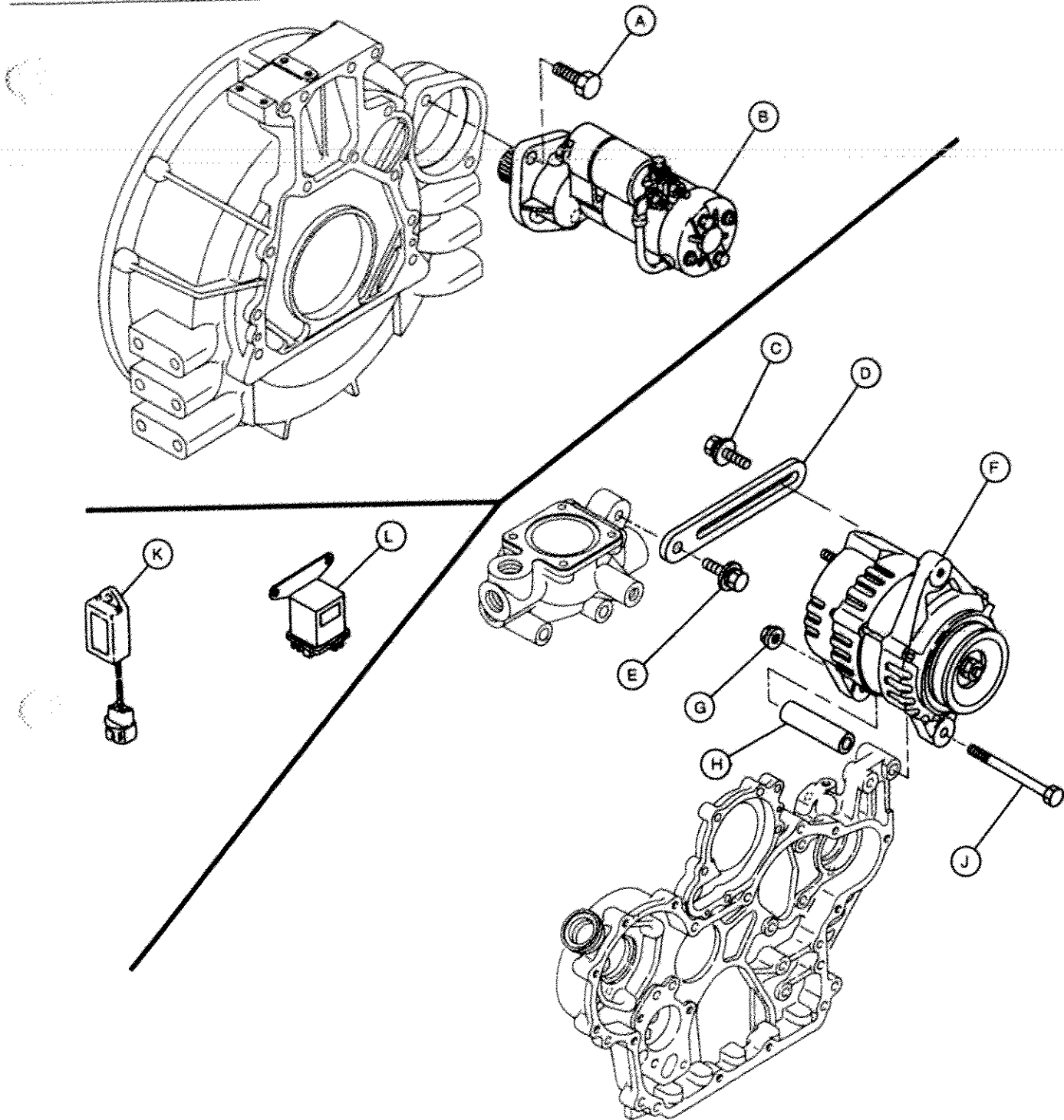

Item	CPN	Qty	Description	Item	CPN	Qty	Description
A	15894793	2	BOLT M12 X 30 PLATED	G	15899206	1	NUT, HEX FALNGE M10-1.5
B	22255566	1	STARTING MOTOR	H	15894827	1	SPACER
C	15898018	1	BOLT	J	15894819	1	BOLT M10 X 120 PLATED
D	15894835	1	ADJUSTER, BELT	K	22245468	1	TIMER
E	15894843	1	BOLT M8 X 25	L	22245482	1	RELAY, FUEL SOLENOID
F	22255574	1	ALTERNATOR				

COOLERS COMPLETE

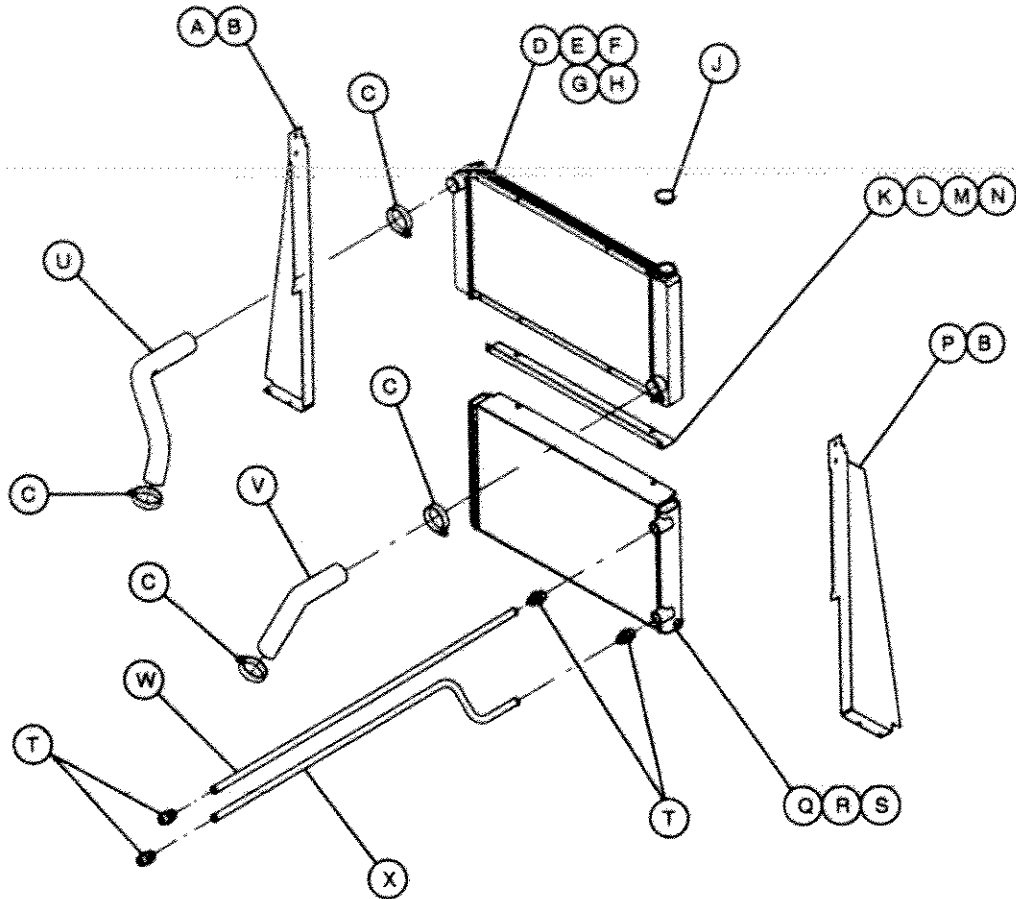

Item	CPN	Qty	Description	Item	CPN	Qty	Description
A	54712815	1	BAFFLE, COOLER CURB SIDE	M	95934998	2	WASHER, FLAT 3/8
B	54729629	1	BAFFLE, COOLER CURB SIDE (GALV)	N	36881886	2	NUT, HEX FLANGE M08
C	35221662	4	CLAMP, HOSE	P	54712807	1	BAFFLE, COOLER STREET SIDE
D	36880516	1	RADIATOR		54729611	1	BAFFLE, COOLER STREET SIDE (GALV)
E	36782176	1	VALVE, DRAIN	Q	36882934	1	COOLER, OIL
F	36785327	2	SCREW, HEX M06-100 X 55	R	35279025	2	SCREW, TAPPING M08-125 X 20
G	95935029	2	WASHER, FLAT 1/4	S	95928230	1	PLUG, HEX CTRSK
H	36769032	2	NUT, HEX LOCK M06	T	35295880	4	CONNECTOR, 1 1/16-12
J	36769560	1	CAP, RADIATOR	U	22178198	1	HOSE, RADIATOR TOP
K	36881480	1	BRACKET, RAD/OIL COOLER	V	22178205	1	HOSE, RADIATOR LOWER
L	96702055	2	SCREW, HEX M08-125 X 20	W	22181143	1	TUBE, TOP OIL
				X	22181150	1	TUBE, BOTTOM OIL



# FAN SHROUD

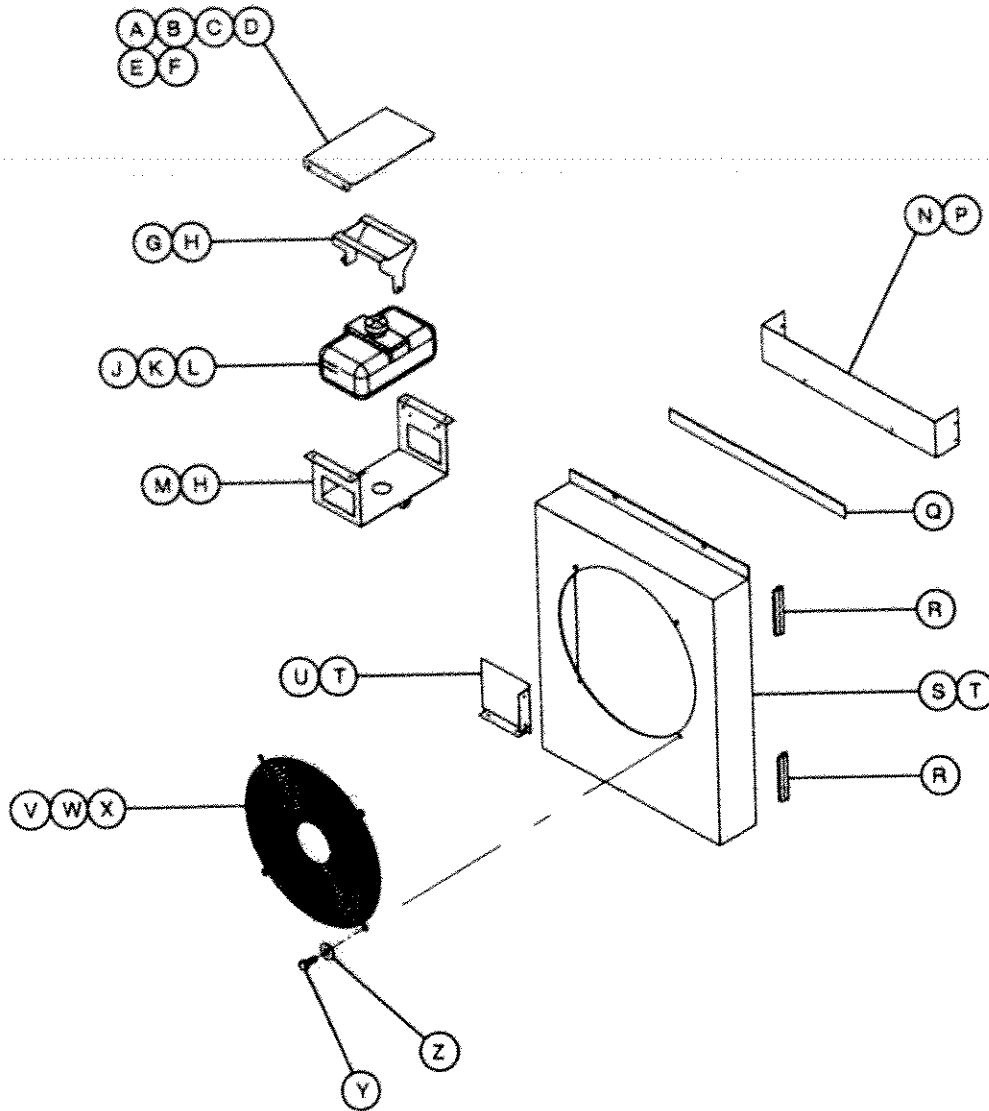

Item	CPN	Qty	Description	Item	CPN	Qty	Description
A	36884500	1	DOOR, RADIATOR ACCESS	N	36881472	1	BAFFLE, COOLER TOP
	54529342	1	DOOR, RADIATOR ACCESS (GALV)		54529243	1	BAFFLE, COOLER TOP (GALV)
B	36890028	2	SPACER, NYLON	P	92368687	4	SCREW, TAPPING M06-100 X 14
C	95934816	2	SCREW, HEX 1/4-20 X 1	Q	35140409	26	STRIP, FOAM
D	95935029	2	WASHER, FLAT 1/4	R	54445176	4	STRIP, SEAL
E	95923298	2	NUT, HEX LOCK 1/4-20	S	22178982	1	SHROUD, FAN
F	35278720	1	PIN, QUICK RELEASE	T	35279025	4	SCREW, TAPPING M08-125 X 20
G	36883874	1	STRAP, WATER BOTTLE HOLDDOWN	U	36920858	1	GUARD, OIL COOLER
H	36797652	5	SCREW, TAPPING M06-100 X 12	V	36884096	1	GUARD, FAN
J	36782043	1	RESERVIOR, OVERFLOW	W	96702055	2	SCREW, TAPPING M08-125 X 20
K	35360775	10*	HOSE, 5/16	X	36881886	2	NUT, HEX FLG M08-1.25
L	35296342	2	CLAMP, HOSE	Y	35300771	4	SCREW, TAPPING M06-1.0 X 20
M	36883866	1	SUPPORT, WATER BOTTLE	Z	36853265	4	WASHER, PLASTIC

AIREND COMPLETE

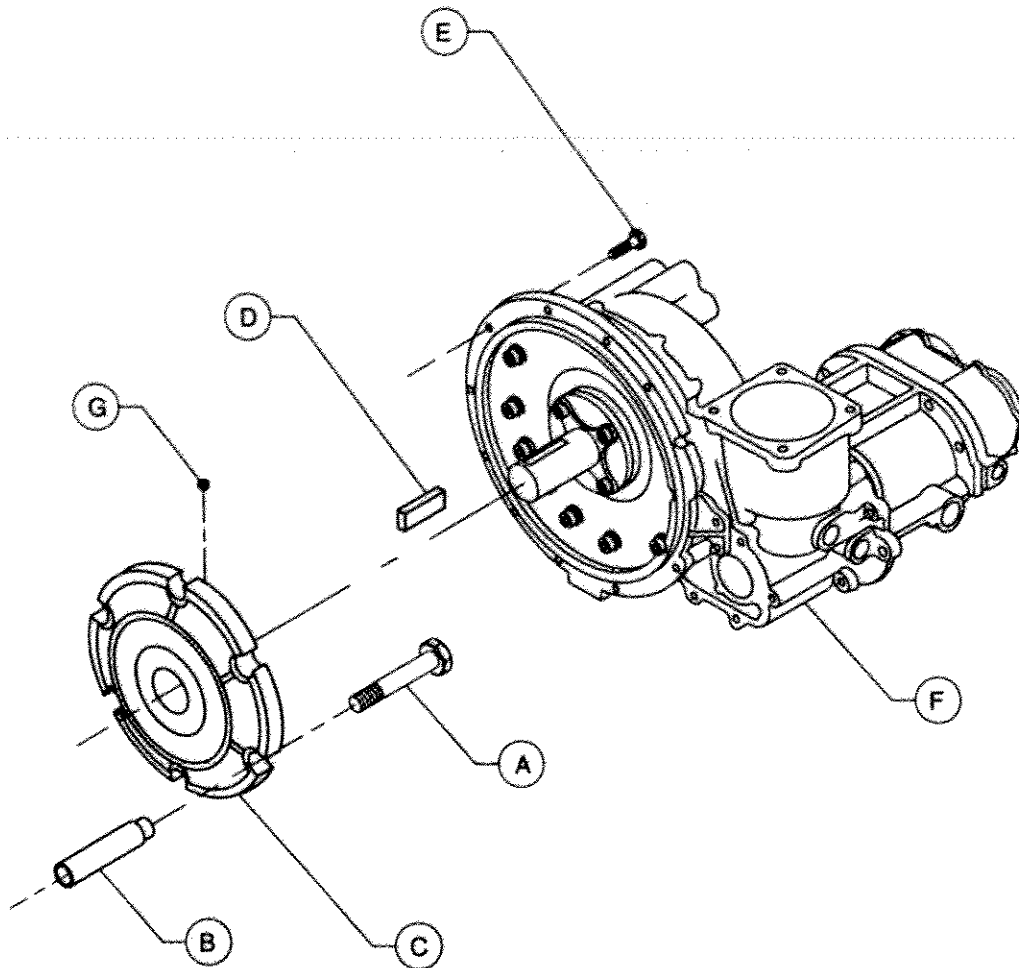

Item	CPN	Qty	Description
A	35353978	8	SCREW, CAP SOC HD M10-1.50 X 50
B	35332295	8	DRIVER, COUPLING M10
C	36865912	1	COUPLING, DRIVE
D	38769289	1	KEY, M8 X 10 X 60
E	36860995	9	SCREW, HEX FLG M10-1.5 X 30.
F	36007854	1	AIR END
G	95378943	1	SCREW, SOCKET SET 3/8-16 X .25

AIR END ASM. (cont'd)

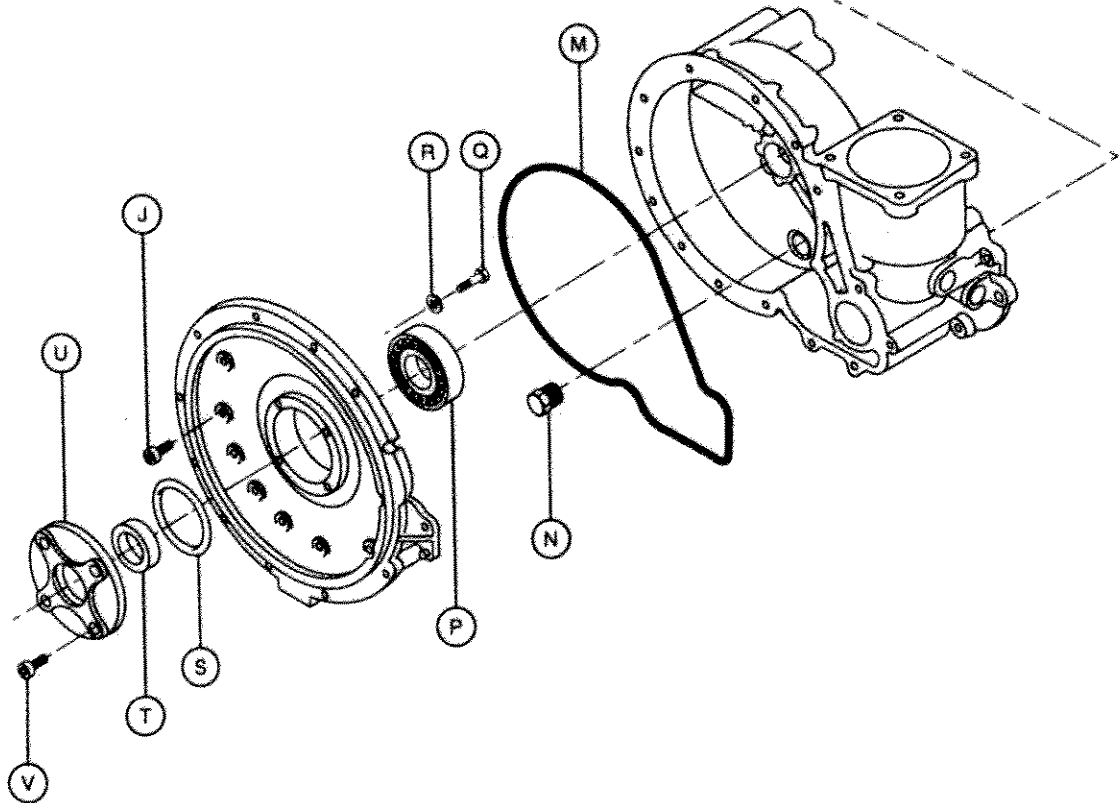
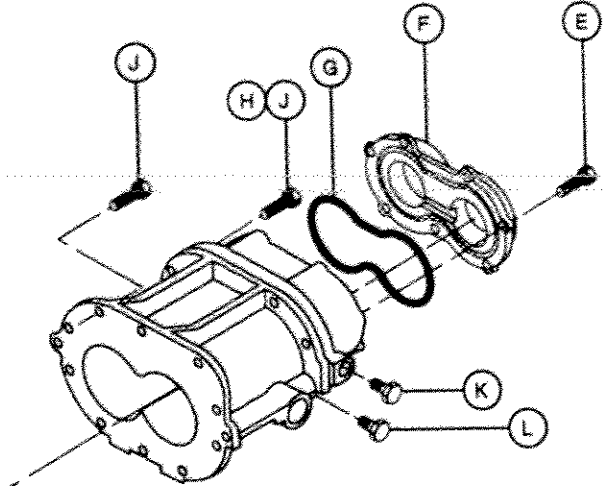
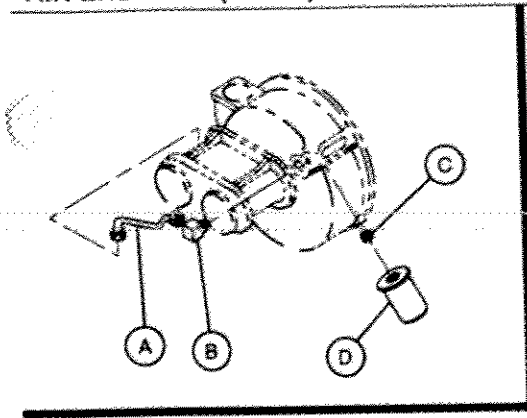

Item	CPN	Qty	Description	Item	CPN	Qty	Description
A	36784553	1	TUBE ASM., OIL INJECTION	L	95280541	1	PLUG, HEX 1.06-12
B	35286491	2	ELBOW	M	95641734	1	O-RING
C	35372986	1	NIPPLE	N	39101449	1	PLUG, SOC HD 3/4
D	36897353	1	FILTER ELEMENT	P	35286004	1	BEARING, BALL
E	96703012	7	SCREW, SOC HD M06-1.0 X 20	Q	36791689	2	SCREW, FLG LOCK M08-1.25 X 16
F	36506442	1	BEARING COVER	R	95094306	2	WASHER, FLAT
G	95023115	1	O-RING	S	95022331	1	O-RING
H	96740375	1	SCREW, SOC HD M08-1.25 X 45	T	35375369	1	SEAL
J	96708060	31	SCREW, SOC HD M08-1.25 X 25	U	39588413	1	SEAL COVER
K	95938965	1	PLUG, HEX 7/16	V	96708037	4	SCREW, SOC HD M08-1.25 X 16

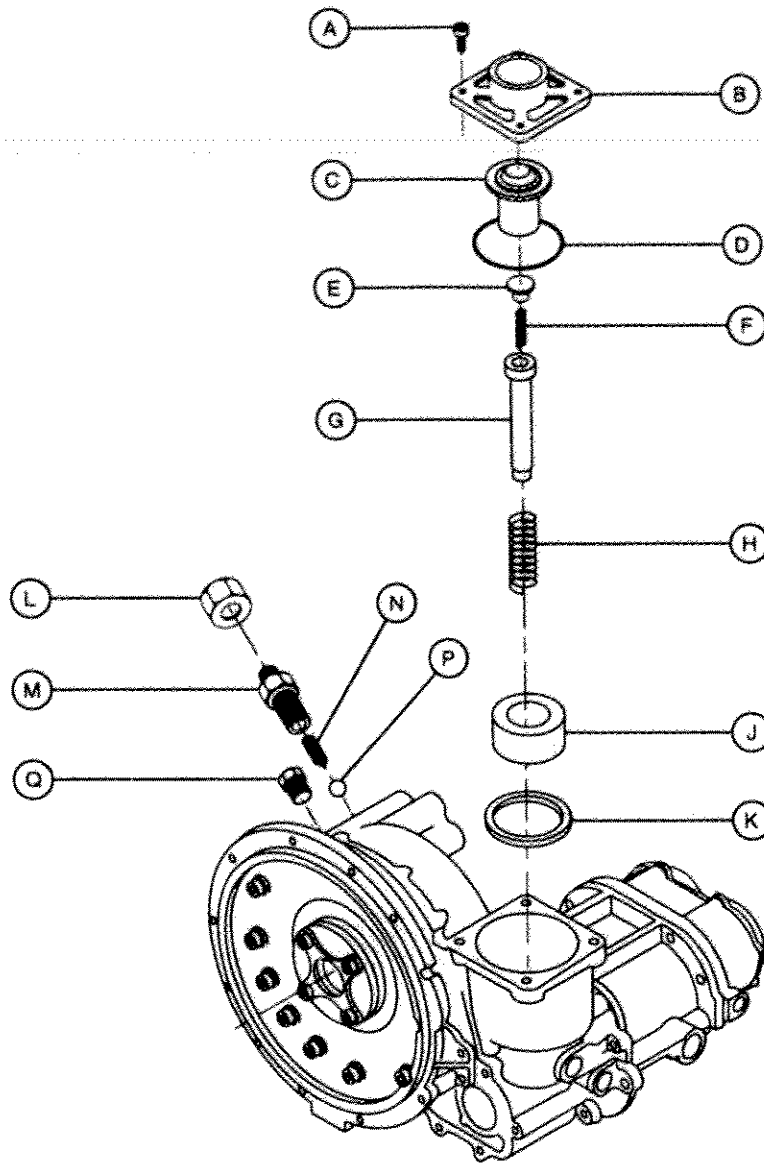

Item	CPN	Qty	Description	Item	CPN	Qty	Description
A	96708144	4	SCREW, SOC HD M10-1.50 X 25	J	35611615	1	PISTON
B	36508471	1	COVER, INLET	K	35376359	1	SEAL
C	36511623	1	VALVE, UNLOADER	L	95257333	1	CAP
D	95023107	1	O-RING	M	35612175	1	CONNECTOR
E	35379817	1	CAP. SPRING	N	35376326	1	SPRING
F	35376342	1	SPRING	P	35376318	1	BALL
G	35611557	1	STEM	Q	95280541	1	PLUG, HEX 1.06-12
H	35376334	1	SPRING				

# OIL TEMP BY-PASS VALVE

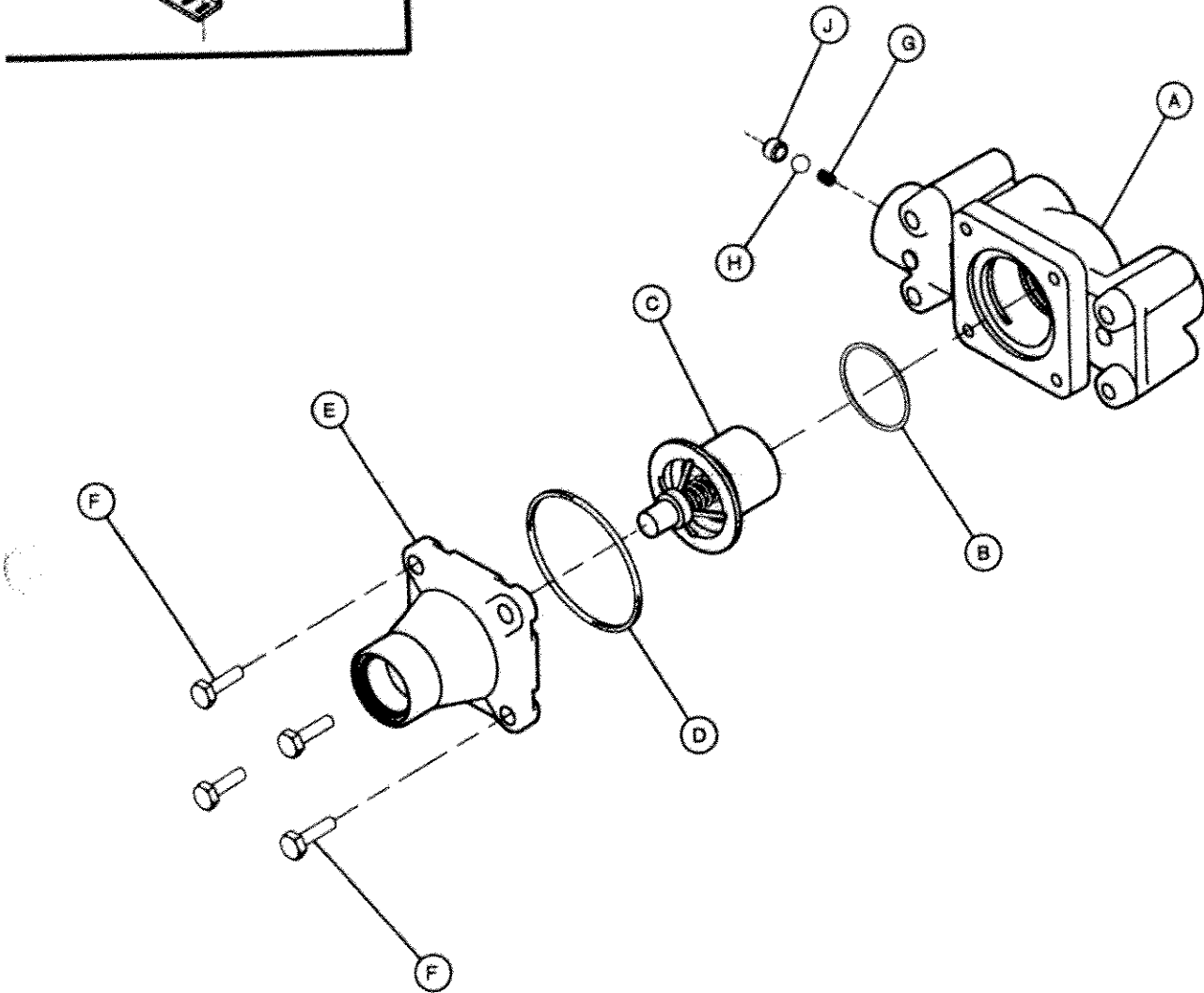
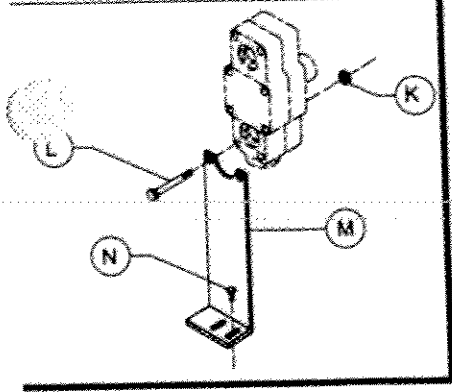

Item	CPN	Qty	Description	Item	CPN	Qty	Description
A	54411640	1	HOUSING, OTBV	H	35288448	1	BALL
B	36788172	1	SEAL, U-TYPE VITON	J	54414677	1	ORIFICE, OIL
C	36782019	1	ELEMENT, 125-145 DEG F	K	36881886	2	NUT, HEX FLG M08-1.25
D	95022307	1	O-RING	L	96718978	2	SCREW, HEX M08-1.25 X 80
E	36765832	1	COVER	M	36890755	1	BRACKET, BYPASS VALVE
F	96702659	4	SCREW, HEX M08-1.25 X 25	N	35279025	2	SCREW, TAPPING M08-1.25 X 20
G	35379940	1	SPRING				

# SEPARATOR TANK COMPLETE

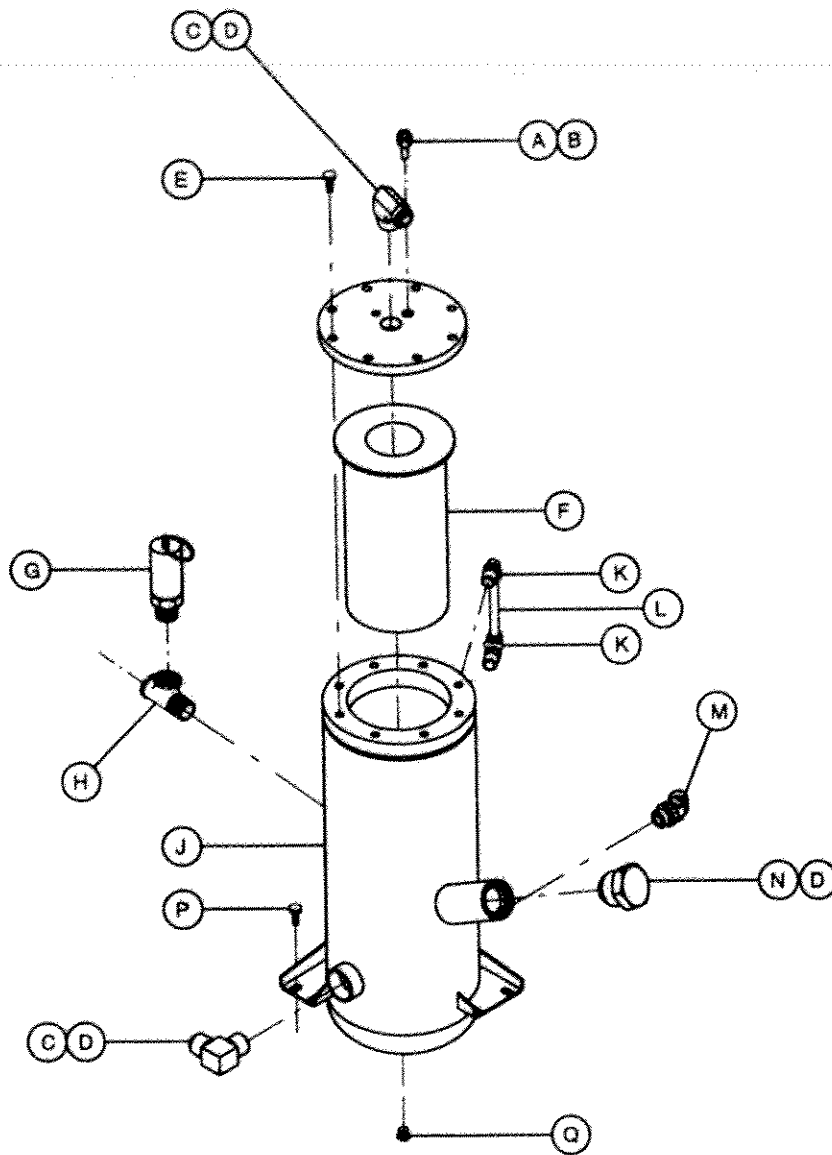

Item	CPN	Qty	Description	Item	CPN	Qty	Description
A	22186381	1	ADAPTER, OIL SCAVANGE	J	22158554	1	TANK, SEPARATOR
B	36840437	1	VALVE, CHECK	K	54627799	2	ELBOW, SIGHT TUBE
C	35279777	2	ELBOW, 90° 1 5/8-12	L	22248454	1	TUBE, SIGHT GAUGE
D	35279942	3	O-RING	M	35294727	1	ELBOW, 45°
E	36877793	8	SCREW, HEX FLANGE HD M12	N	35579630	1	PLUG 1 5/8
F	54625942	1	ELEMENT, SEPARATOR	P	35279025	4	SCREW, TAPPING M08-1.25 X 20
G	35325166	1	VALVE, SAFETY	Q	95280541	1	PLUG, HEX 1.06-12
H	95944708	1	TEE, STREET NPT 1/2				

# SERVICE AIR COMPLETE

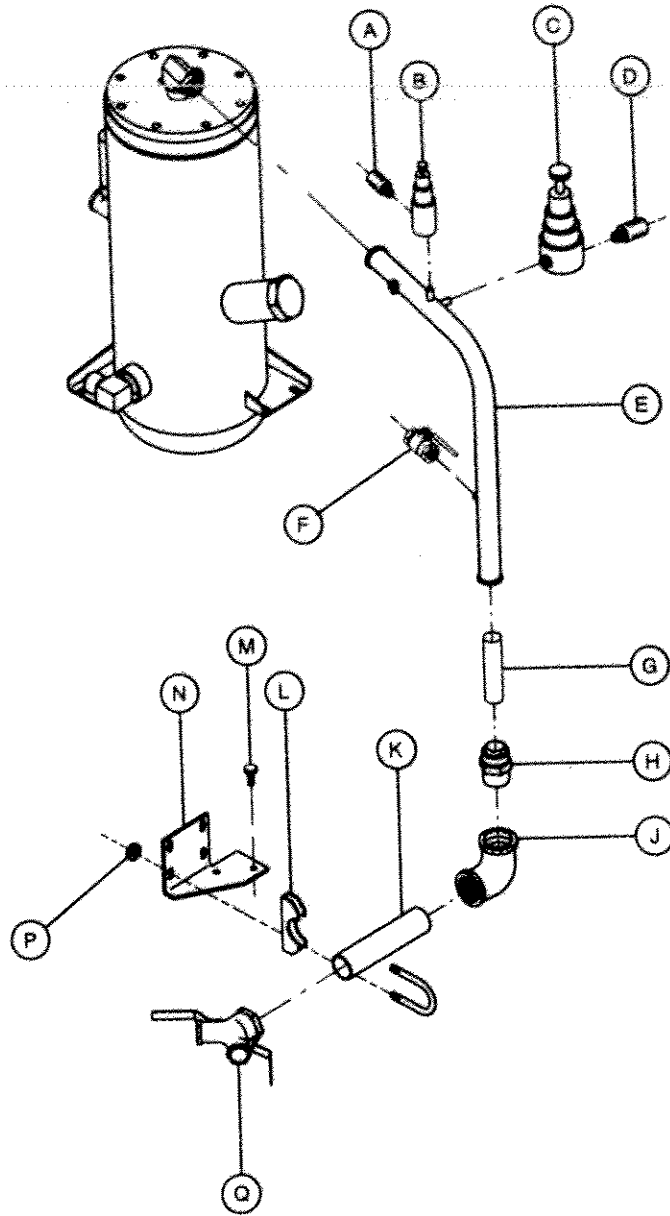

\* 35379064 DIAPHRAM REPAIR KIT  
 \*\* 35387919 DIAPHRAM REPAIR KIT

Item	CPN	Qty	Description	Item	CPN	Qty	Description
A	36766756	1	ORIFICE, .140 MUFFLER	J	95953378	1	ELBOW, 1 1/4 NPT
B **	36854149	1	VALVE, PRESSURE REGULATOR	K	95944542	1	NIPPLE, LONG 1.25 X 7.0
C *	35322379	1	VALVE, BLOWDOWN	L	36785277	2	CLAMP, SADDLE 1 5/8
D	36766772	1	ORIFICE, .062 MUFFLER	M	35279025	4	SCREW, TAPPING M08-1.25 X 20
E	22234884	1	TUBE, SERVICE	N	22226617	1	BRACKET, SERVICE PIPE
F	35324839	1	VALVE, BALL	P	95923314	4	NUT, HEX LOCK 5/16-18
G	36921377	1	NOZZLE, .395 SONIC ORIFICE	Q	36881076	1	VALVE, WYE
H	95219770	1	ADAPTER 1 1/4				

# FUEL / WATER FILTER

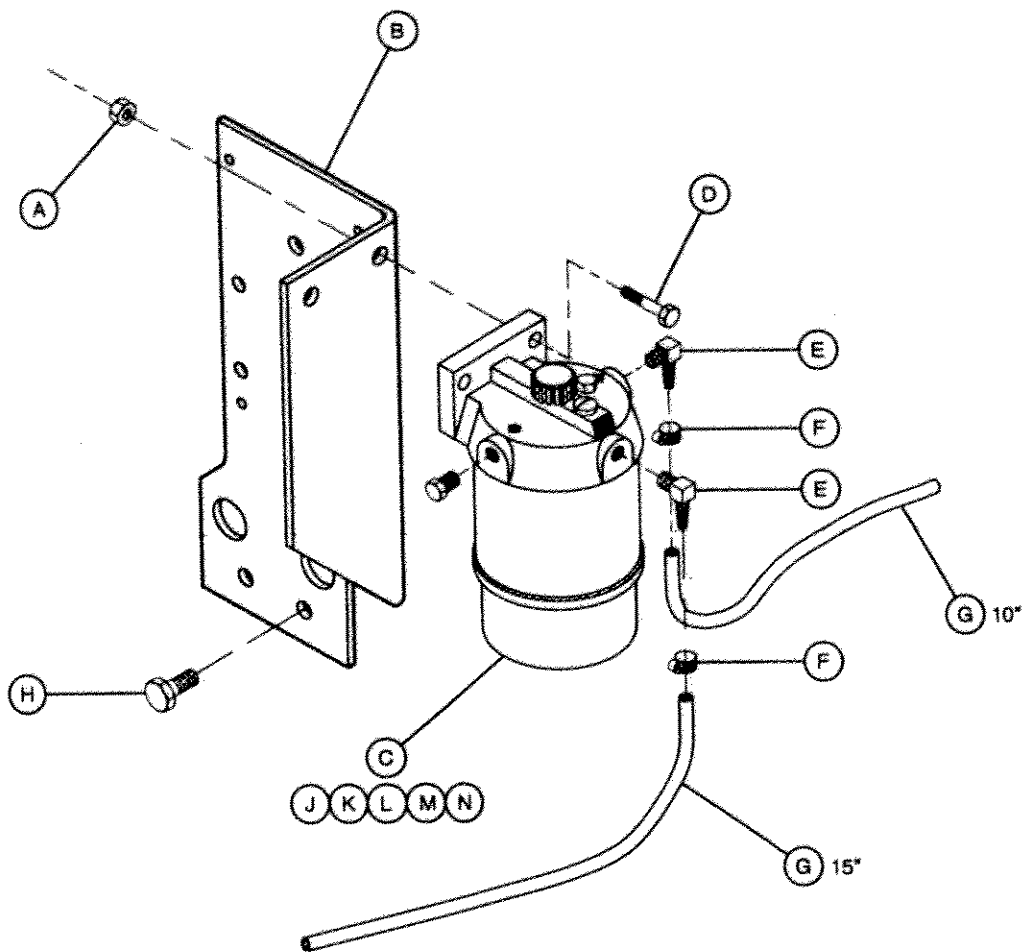

\* AS REQUIRED

\*\* INCLUDED IN FUEL / WATER SEPARATOR FILTER

Item	CPN	Qty	Description	Item	CPN	Qty	Description
A	36881886	2	NUT, HEX FLANGE M08-1.25	H	35279025	2	SCREW, TAPPING M08-1.25 X 20
B	36883890	1	BRACKET, ETHER/FUEL FILTER	J	54525530	**	ASSEMBLY, ELEMENT
C	54525506	1	FILTER, FUEL/WATER SEPARATOR	K	54480504	**	BOWL
D	36889608	2	SCREW, HEX FLANGE M08-1.25 X 25	L	54480512	**	HEAD
E	35378538	2	ELBOW, BARBED	M	35358381	**	COVER, CHECK BALL
F	35296342	4	CLAMP	N	54480520	**	PLUG, VENT
G	35363498	*	HOSE, 5/16 FUEL				



FUEL TANK COMPLETE

DRAWBAR END

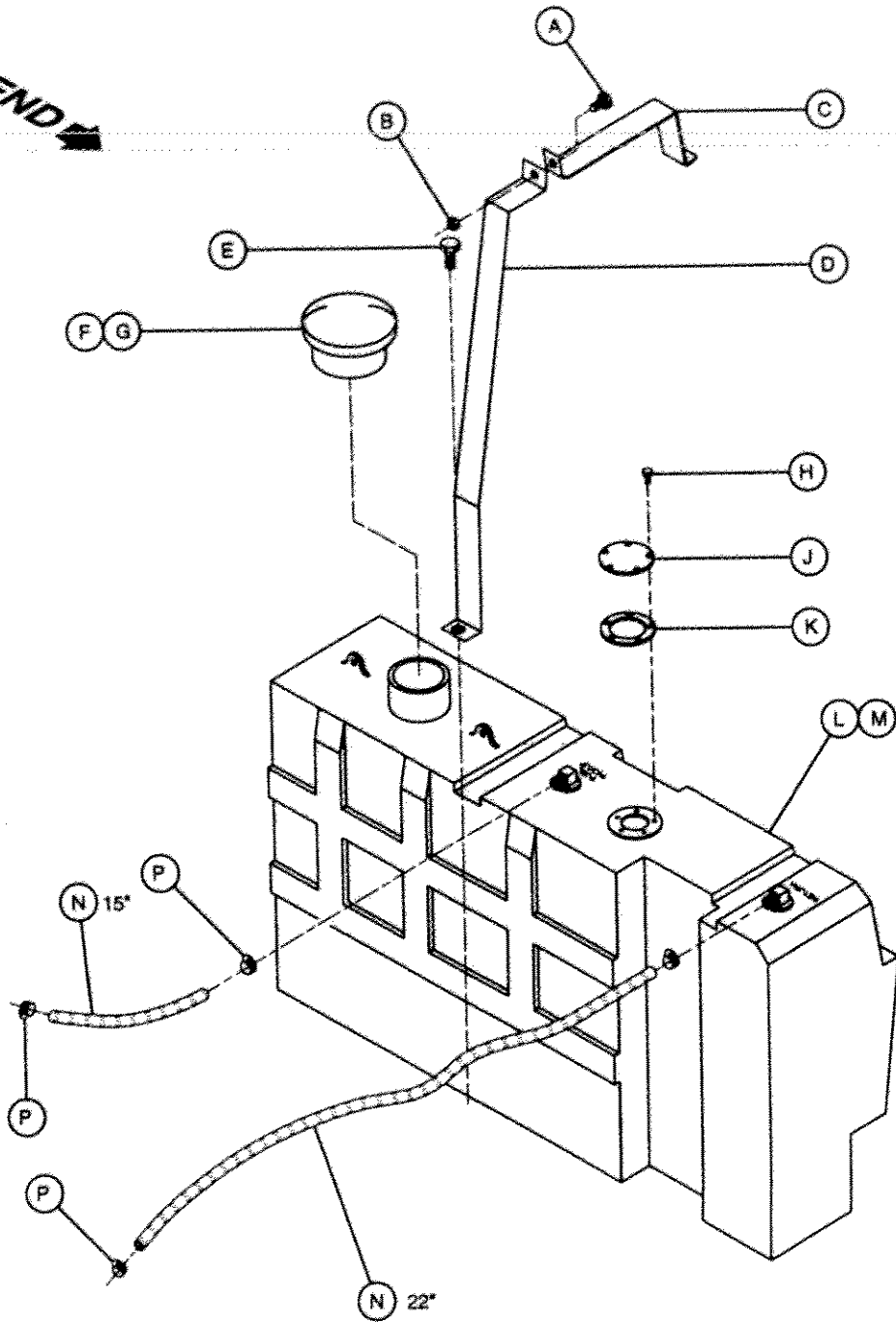

\* SEE ILLUSTRATION FOR LENGTH  
 \*\* INCLUDED WITH TANK

Item	CPN	Qty	Description	Item	CPN	Qty	Description
A	35271170	1	SCREW, TAPPING M08-125 x 40	H	95946532	5	SCREW, HEX 10-32 X 1/2
B	35278530	1	NUT, HEX NYLOCK M08	J	36792828	1	COVER, FUEL SENDER
C	36884245	1	STRAP, HOLD DOWN	K	35361849	1	GASKET, FUEL SENDER
D	22247951	1	STRAP, HOLD DOWN	L	36881100	1	TANK, FUEL
E	35279025	1	SCREW, TAPPING M08-125 x 20	M**	35384577	2	BUSHING
F	36859049	1	CAP, FUEL	N	35363498	*	HOSE, 5/16 FUEL
G	36385111	1	GASKET, FUEL CAP	P	35296342	4	CLAMP, WORM GEAR

## AIR INTAKE FILTERS, RELAYS & FUEL FILTER MTG.

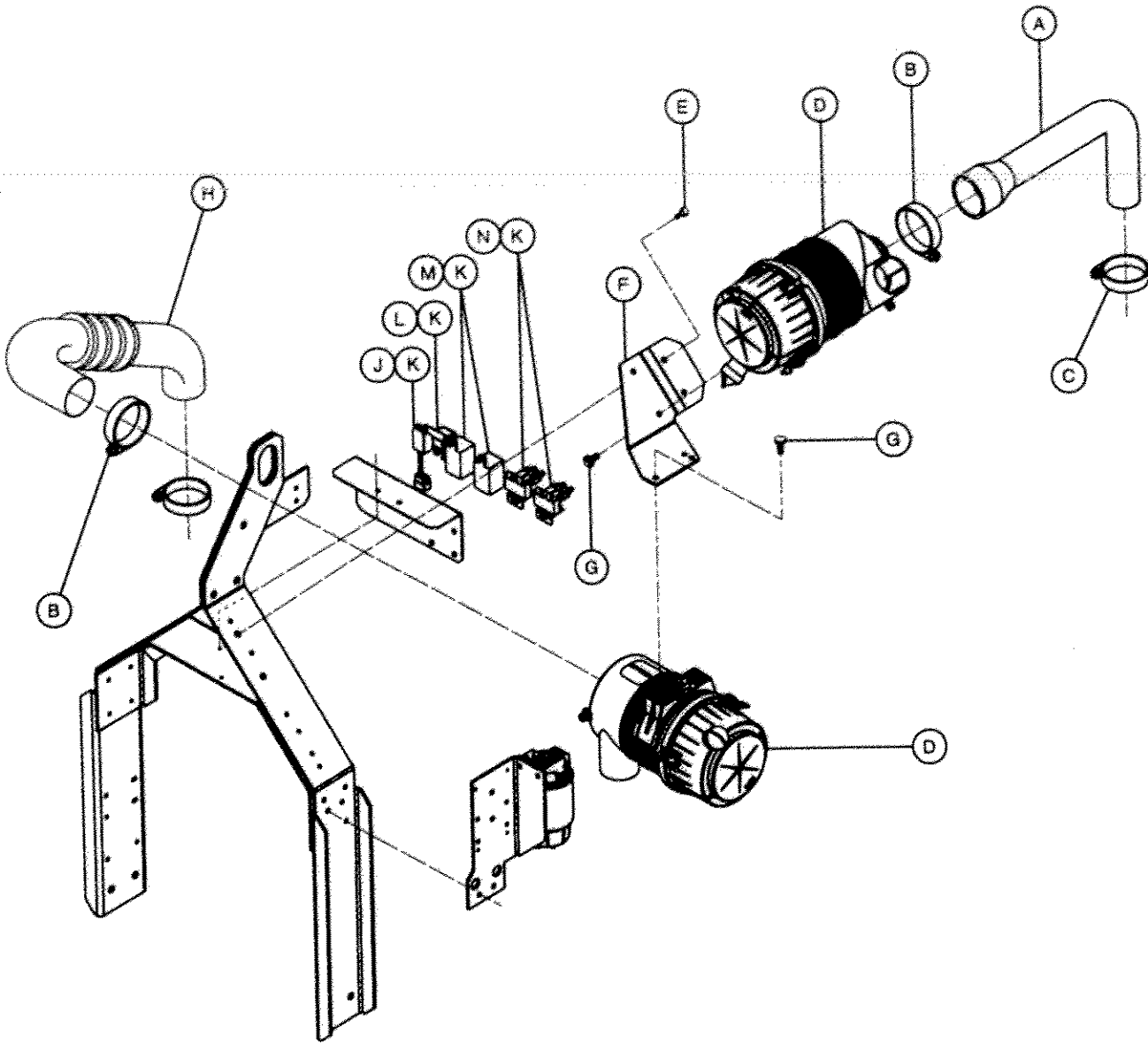

Item	CPN	Qty	Description	Item	CPN	Qty	Description
A	22198743	1	HOSE, ENGINE INTAKE	H	36880912	1	HOSE, A/E INTAKE
B	35374073	3	CLAMP, T 3.62"	J	22245468	1	TIMER
C	35295773	1	CLAMP, T 2.56"	K	36797652	10	SCREW, TAPPING M06-1.0 X 12
D	36897999	2	CLEANER ASM., AIR	L	22245492	1	RELAY, FUEL SOLENOID
E	35279025	2	SCREW, TAPPING M08-1.25 X 20	M	36878361	2	RELAY, BYPASS
F	36897985	1	BRACKET, AIR CLEANER	N	36856250	2	RELAY, AIR INTAKE HEATER
G	96702048	4	SCREW, HEX M08-1.25 X 16				

# AIR CLEANER ASM.

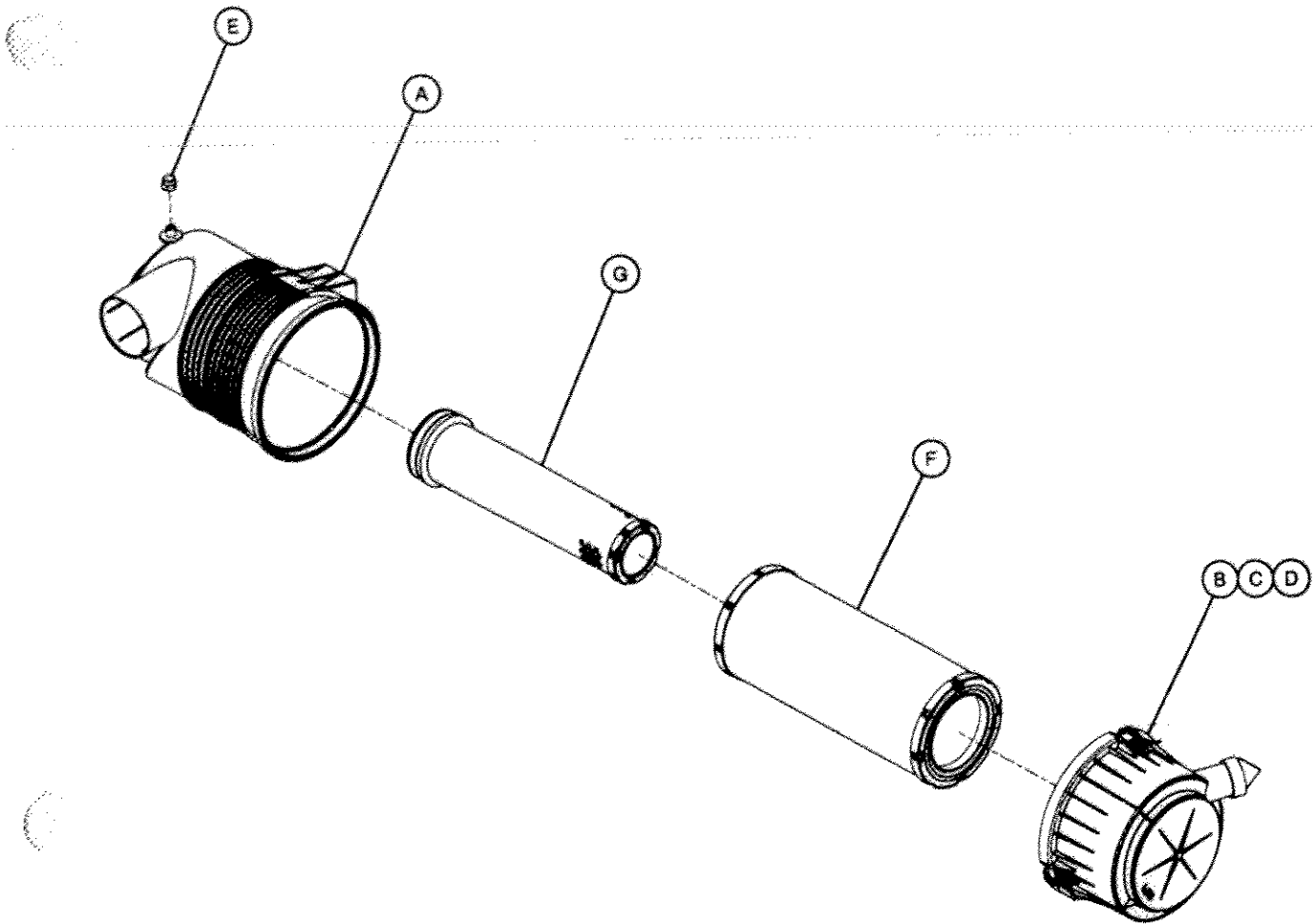

Item	CPN	Qty	Description
A	35393701	1	BODY, AIR CLEANER
B	35393693	1	COVER, AIR CLEANER
C	35393669	3	CLIP, RETAINING
D	35393677	1	VALVE, DUST EJECTOR
E	35393719	1	PLUG, CAP
F	35393685	1	ELEMENT, PRIMARY
G	35393651	1	SAFETY ELEMENT (OPTION)

# BATTERY ASSEMBLY

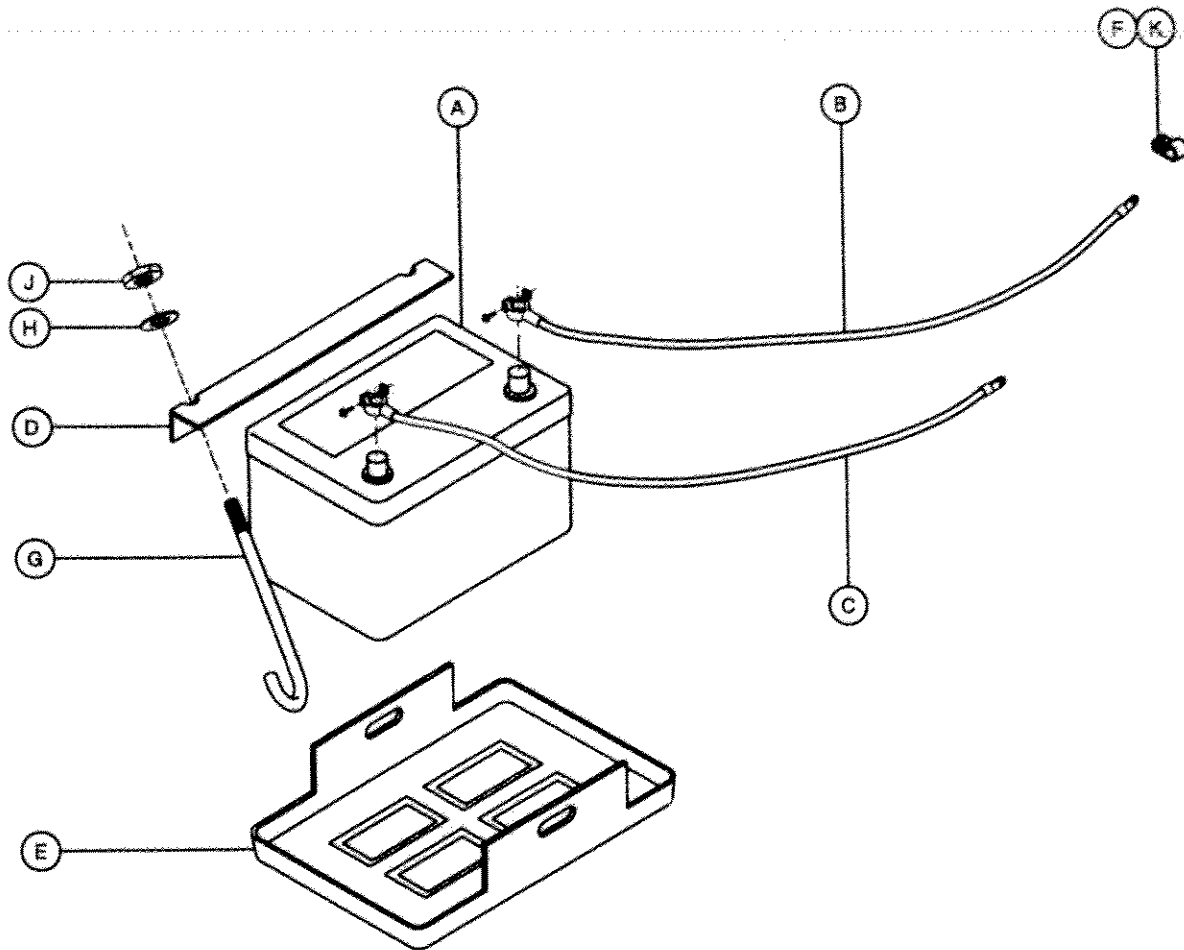

Item	CPN	Qty	Description
A	36844264	1	BATTERY
B	35516582	1	CABLE, POSITIVE BATTERY
C	35582402	1	CABLE, NEGATIVE BATTERY
D	36853257	1	ANGLE
E	36878064	1	TRAY, BATTERY
F	35225093	2	CLAMP, 1/2" SUPPORT
G	36860005	2	J-BOLT
H	36853265	2	WASHER, PLASTIC
J	95923298	2	NUT, LOCK 1/4-20
K	35279025	2	SCREW, TAPPING M08-1.25 X 20

# INST/CONTROL PANEL

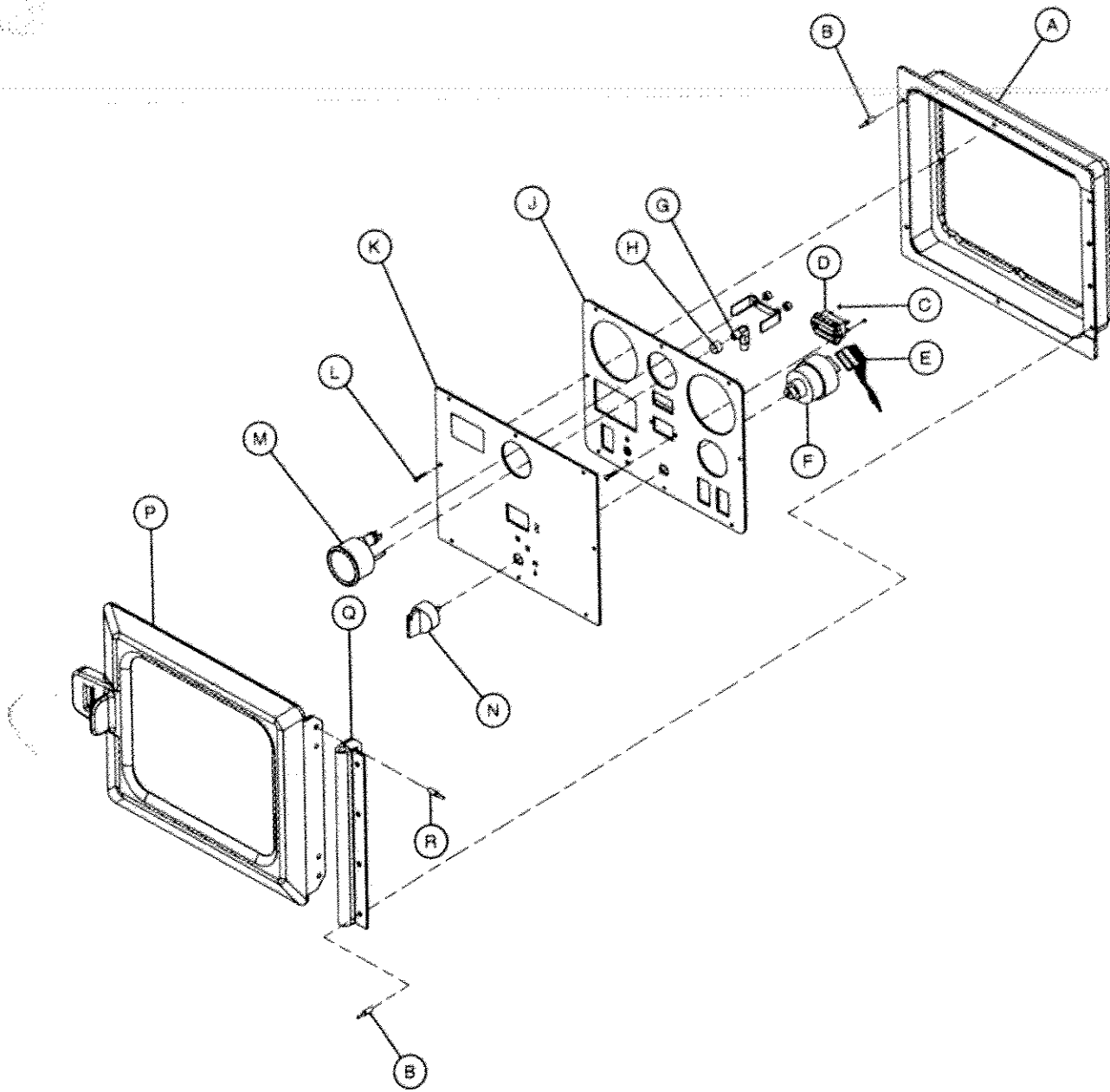

Item	CPN	Qty	Description	Item	CPN	Qty	Description
A	54749601	1	FRAME, WW INSTR PANEL	K	22171698	1	DECAL, WW INSTR PANEL
B	54721212	6	RIVET, 3/16 ALUMINUM	L	22070494	8	SCREW, PLASTIC TAPPING
C	22054159	2	NUT, PLASTIC 4-40	M	35604065	1	GAUGE, 150 PSI PRESSURE
D	54766704	1	METER, ELECTRONIC HOUR	N	22134118	*	KNOB ASM.
E	22199079	1	ADAPTER, SWITCH	P	54482500	1	DOOR, INST PNL ( STD. PAINT)
F	22127385	1	SWITCH, IGNITION		54729199	1	DOOR, INST PNL (SPECIAL PAINT)
G	35370386	1	ELBOW, 1/8 NPT X 3/8 TUBE	Q	22107478	1	HINGE, CONTROL PANEL
H	95935599	1	COUPLING, STD 1/8 NPT X .75	R	54721220	4	RIVET, 3/16 ALUMINUM
J	22171690	1	PANEL, INSTRUMENT				

\* INCLUDED WITH IGNITION SWITCH

# WIRING DIAGRAM

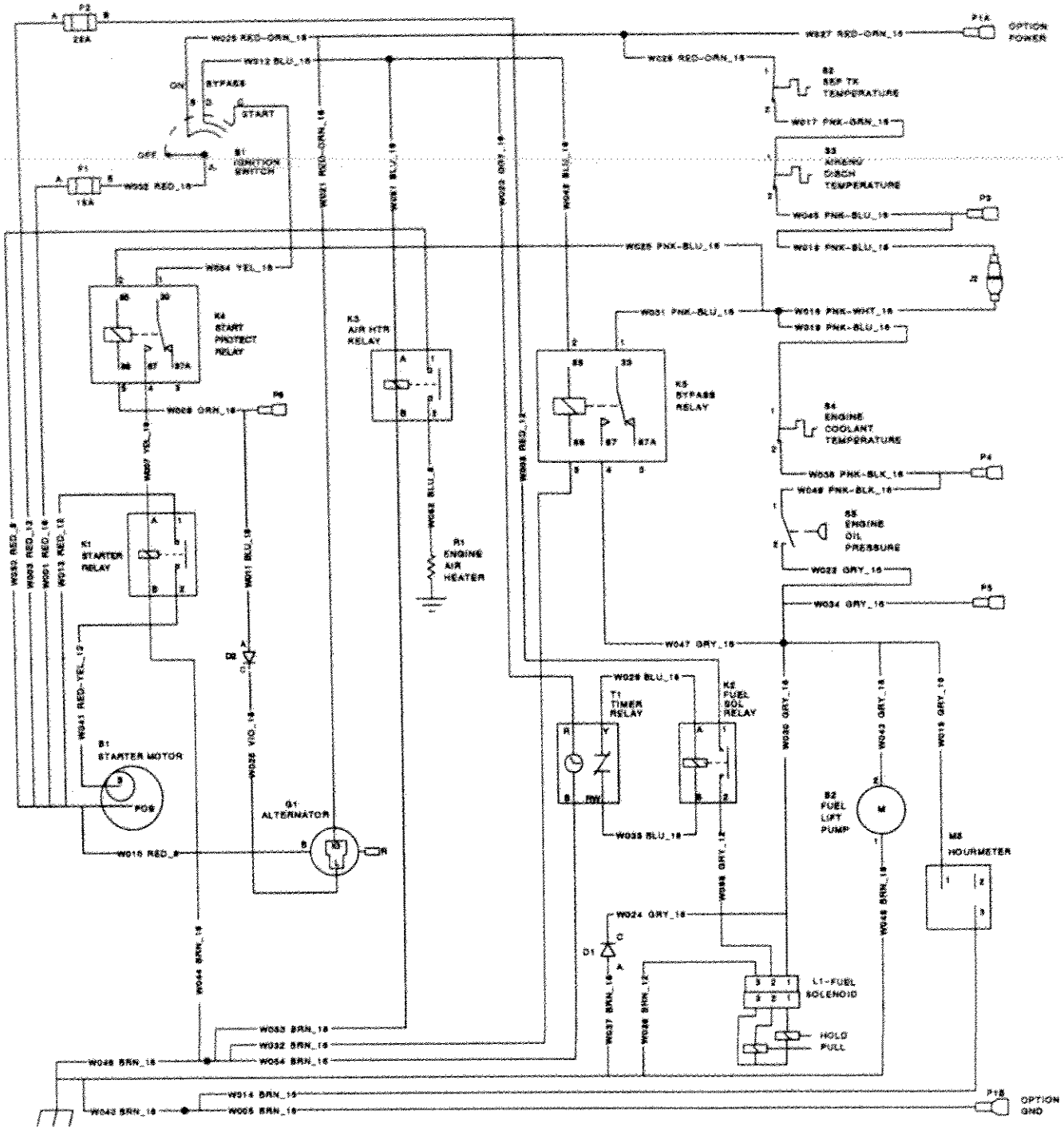

Item	CPN	Description	Item	CPN	Description
B1	22255566	STARTER	K5	36878361	BYPASS RELAY
B2	22226385	FUEL PUMP	L1	22226393	ENGINE STOP SOLENOID
D1	35376169	DIODE	M5	54766704	HOURMETER
D2	35376169	DIODE	R1	15899842	AIR INTAKE HEATER
F1	36888154	FUSE, 15A	S1	22127385	IGNITION SWITCH
F2	36793651	FUSE, 25A	S2	36865756	SEP TK TEMP SWITCH
G1	22255574	ALTERNATOR	S3	35596436	DISCHARGE AIR TEMP SWITCH
K1	36856250	STARTER RELAY	S4	15898059	ENG COOLANT TEMP SWITCH
K2	22245492	FUEL SOL RELAY	S5	15898996	ENG OIL TEMP SWITCH
K3	36856250	AIR HEATER RELAY	T1	22245468	TIMER
K4	36878361	START PROTECT RELAY	W1	22218721	HARNES, CHASSIS

# TAIL LIGHT WIRING DIAGRAM

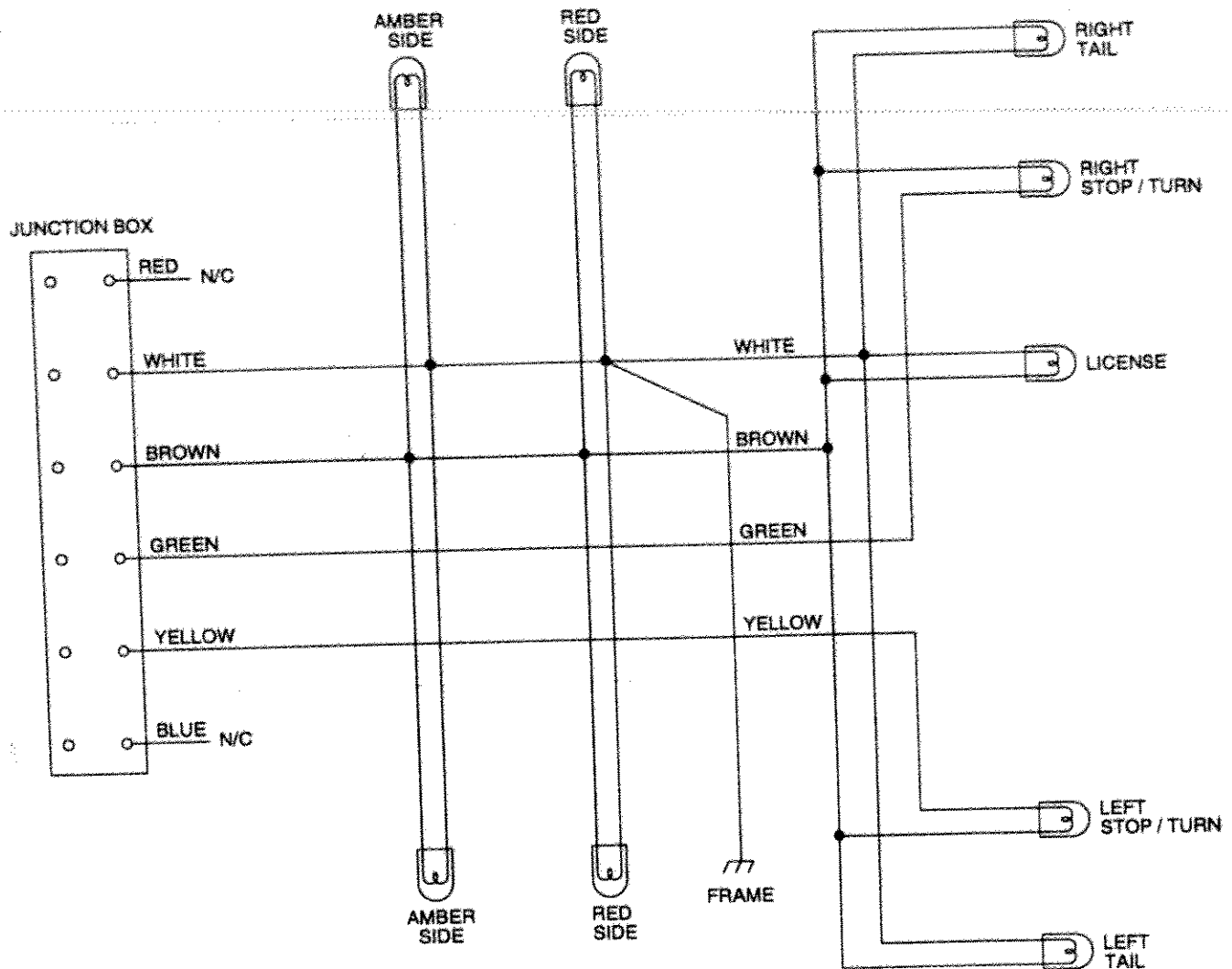

## PLUG / SOCKET WIRING CONNECTIONS

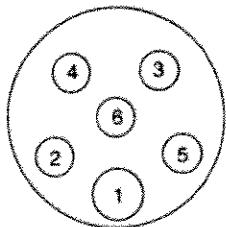

- 1 WHITE - GROUND
- 2 YELLOW - LEFT STOP/TURN SIGNAL
- 3
- 4 GREEN - RIGHT STOP/TURN SIGNAL
- 5 BROWN - TAIL / CLEARANCE LIGHTS
- 6 BLUE - ELECTRIC BRAKES

Item	CPN	Qty
LICENSE	54726468	1
SIDE, AMBER	35367051	2
SIDE, RED	35367044	2
TAIL / STOP	36788081	2
HARNES, LIGHT	38893196	1

NOTES:

SEE NEXT PAGE FOR MATCH POINTS

A B C D E

\* 35379064 DIAPHRAM REPAIR KIT

\*\* 35387919 DIAPHRAM REPAIR KIT

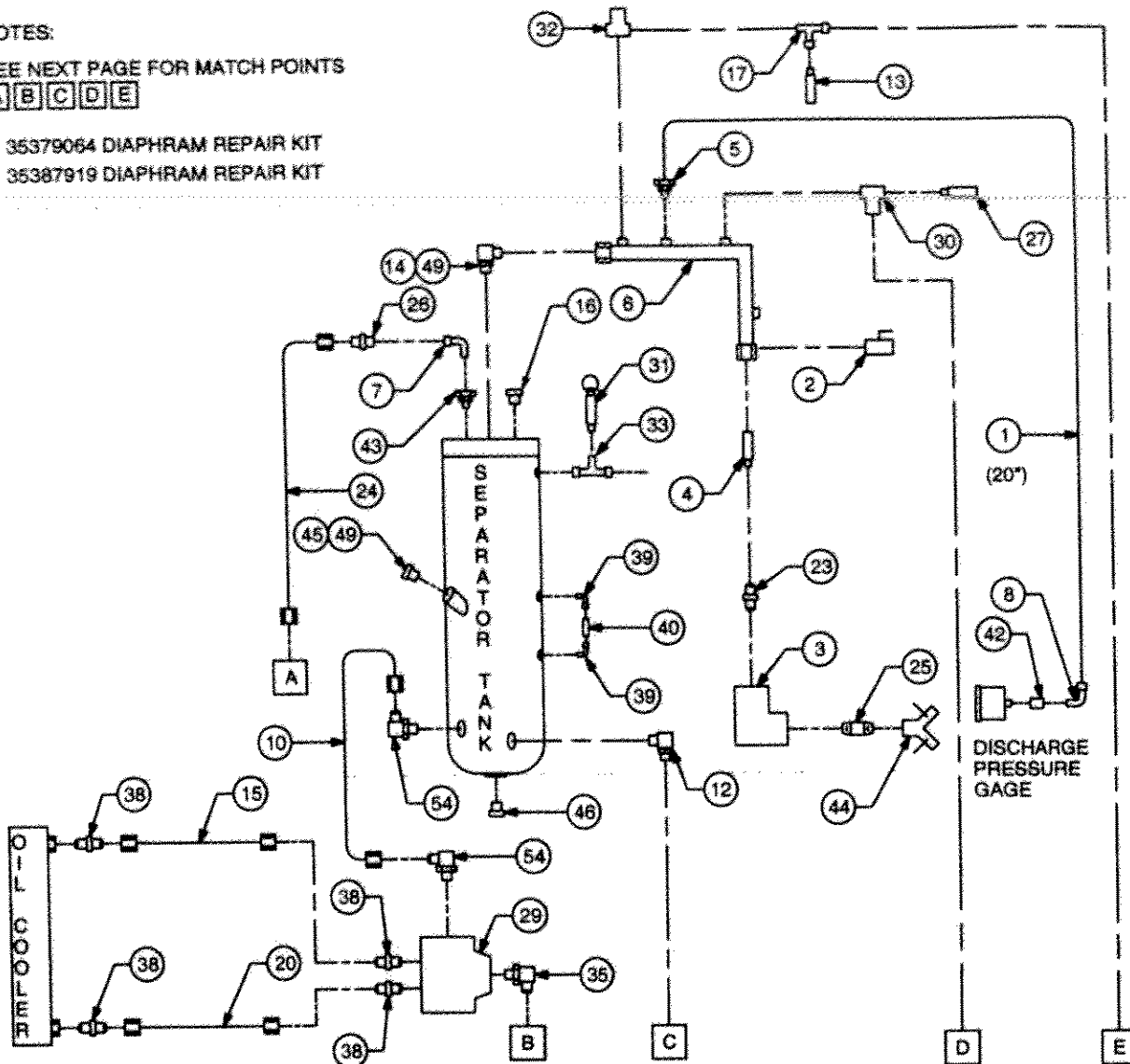

Item	CPN	Description	Item	CPN	Description
1	35356484	TUBING	25	95944542	NIPPLE, 1.25 X 7.0
2	35324839	BALL VALVE	26	36840437	ORIFICE/CHECK VALVE
3	95953378	ELBOW, 90° 1 1/4NPT	27	36768772	MUFFLER, .062 ORIFICE
4	36921690	NOZZLE, SONIC (P110A)	29	54411665	VALVE, BYPASS
	36923910	NOZZLE, SONIC (P135A)	* 30	35322379	VALVE, BLOWDOWN
5	35369347	CONNECTOR	31	35325168	VALVE, SAFETY
6	22234884	SERVICE TUBE	** 32	36854149	VALVE, PRESS REG
7	95944666	ELBOW, STREET 1/4 NPT	33	95944708	TEE, STREET 1/2 NPT
8	35370386	ELBOW, 90° 1/4NPT X 3/8	35	35294750	ELBOW, 90° 1 1/16-12
10	35287721	HOSE ASSEMBLY	38	35295880	STRAIGHT CONNECTOR
12	35374867	ELBOW, 90° 1 7/8-12	39	54727799	ELBOW, SIGHT TUBE
13	36786756	MUFFLER, .140 ORIFICE	40	22248454	TUBE, SIGHT
14	35279777	ELBOW, 90° 1 5/8-12	42	95930319	COUPLING, 1/8 NPT
15	22181150	TUBE ASM., COOLER BOTTOM	43	22186381	ADAPTER, OIL SCAVANGE
16	95928230	PLUG	44	36881076	VALVE, SERVICE
17	35114545	TEE, STREET 1/4NPT	45	35579630	PLUG, VENTED 1.62
20	22181143	TUBE ASM., COOLER TOP	46	95664934	PLUG
23	95219770	CONNECTOR, 1.25-12 X 1.25NPT	49	35279942	O-RING
24	35228212	HOSE ASM.	54	35294727	ELBOW, 45°



# AIR & OIL PIPING (cont'd)

NOTES:

SEE PREVIOUS PAGE FOR MATCH POINTS

**B C D E**

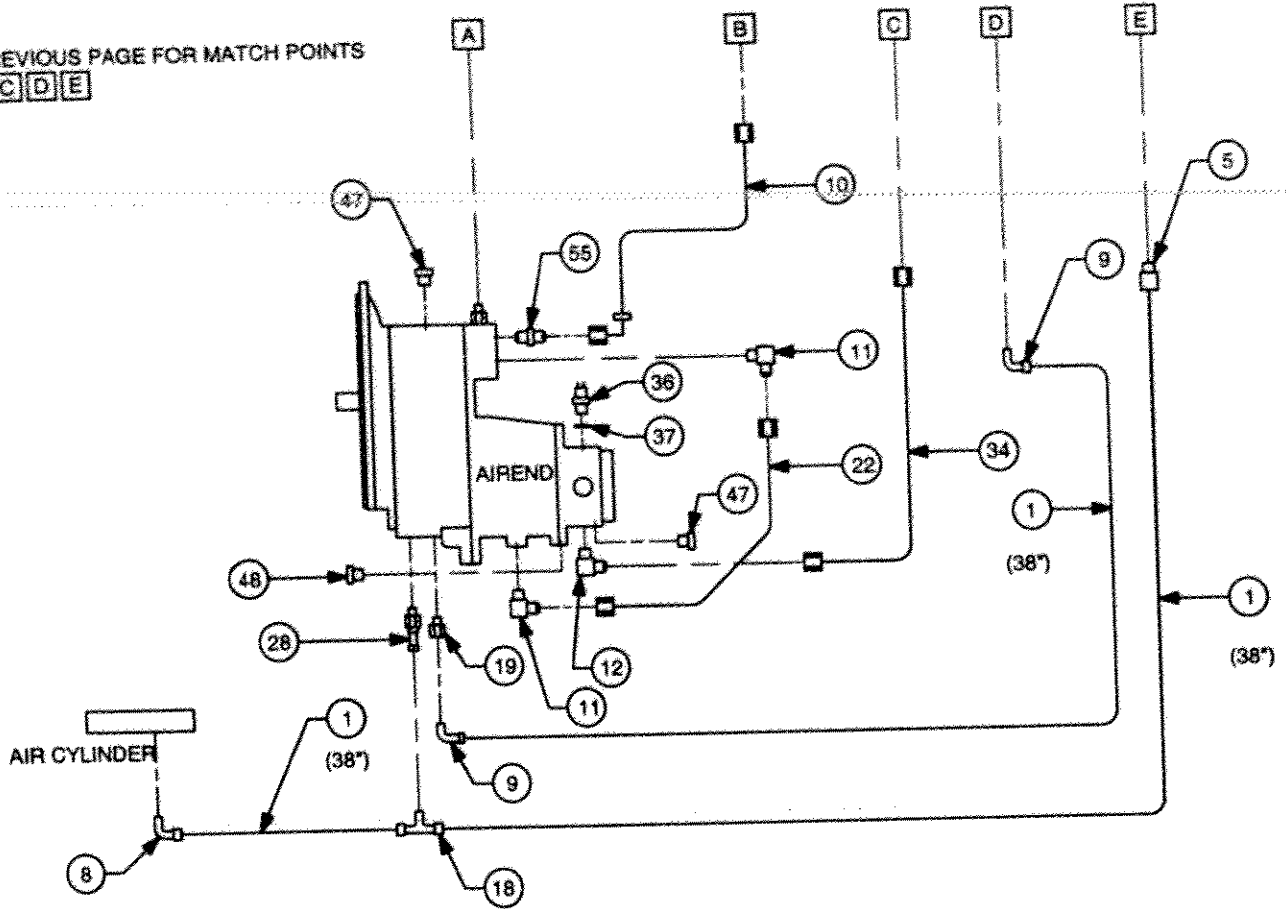

Item	CPN	Description	Item	CPN	Description
1	35356484	TUBING	22	36764553	TUBE ASSEMBLY
5	35369347	CONNECTOR	28	36886992	VALVE, CHECK .078
8	35370386	ELBOW, 90° 1/8NPT X 3/8	34	36886752	DISCHARGE HOSE
9	35368354	ELBOW, 90° 1/4NPT X 3/8	36	35596436	SHUTDOWN SWITCH
10	35287721	HOSE ASSEMBLY	37	39404165	O-RING
11	35286491	ELBOW, 90° 7/8-14	47	35287556	PLUG, HEX 5/8-18
12	35374867	ELBOW, 90° 1 7/8-12	48	35289057	PLUG, HEX 7/16-20
18	35369396	TEE, 1/8NPT	55	36885093	ELBOW, 90° LONG
19	35302314	ADAPTER			

NOTES:

SEE PREVIOUS PAGE FOR MATCH POINTS



ELECTRIC  
START / RUN  
VALVE  
OPTION

DUEL REGULATION  
OPTION XP185WJD

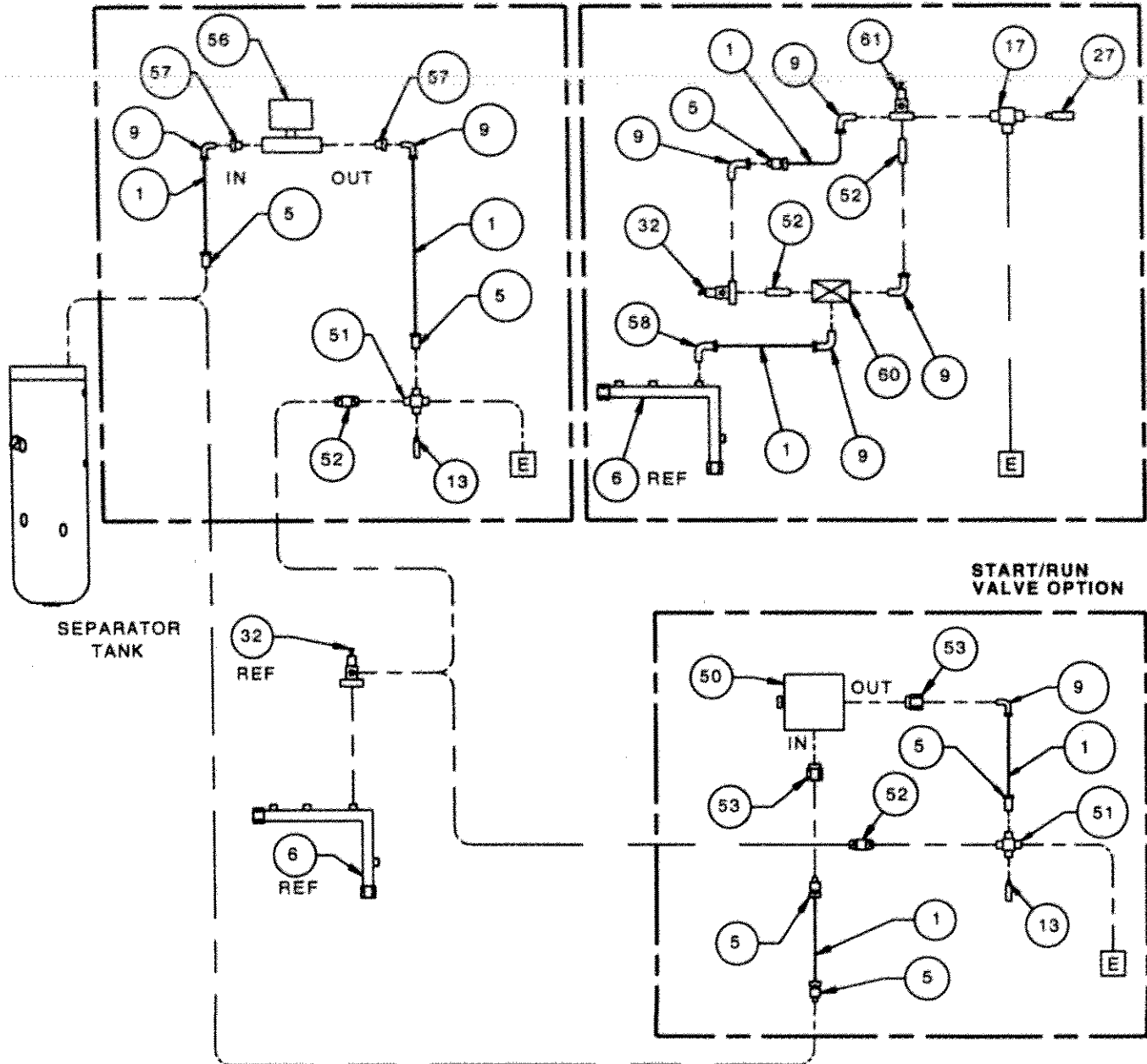

Item	CPN	Description	Item	CPN	Description
1	35356484	TUBING	50	36783439	VALVE, 2-WAY
5	35369347	CONNECTOR	51	95954293	CROSS, 1/4 NPT
6	22234884	TUBE ASM., SERVICE	52	95667341	NIPPLE, 1/4 NPT X .88
9	35369354	ELBOW, 90° 1/4NPT X 3/8	53	35302314	ADAPTOR, 9/16 X 1/4NPT
13	36766756	MUFFLER, .140 ORIFICE	56	36843142	VALVE, SOLENOID 24V
17	35114545	TEE, STREET 1/4NPT.	57	95940748	BUSHING, REDUCER 3/8 NPT X 1/4 NPT
27	36766772	MUFFLER, .062 ORIFICE	58	95954095	ELBOW, 90° X 1/4 NPT.
32	36854149	VALVE, PRESS REG	61	35359090	REGULATOR, PRESSURE

ENCLOSURE COMPLETE (cont'd)

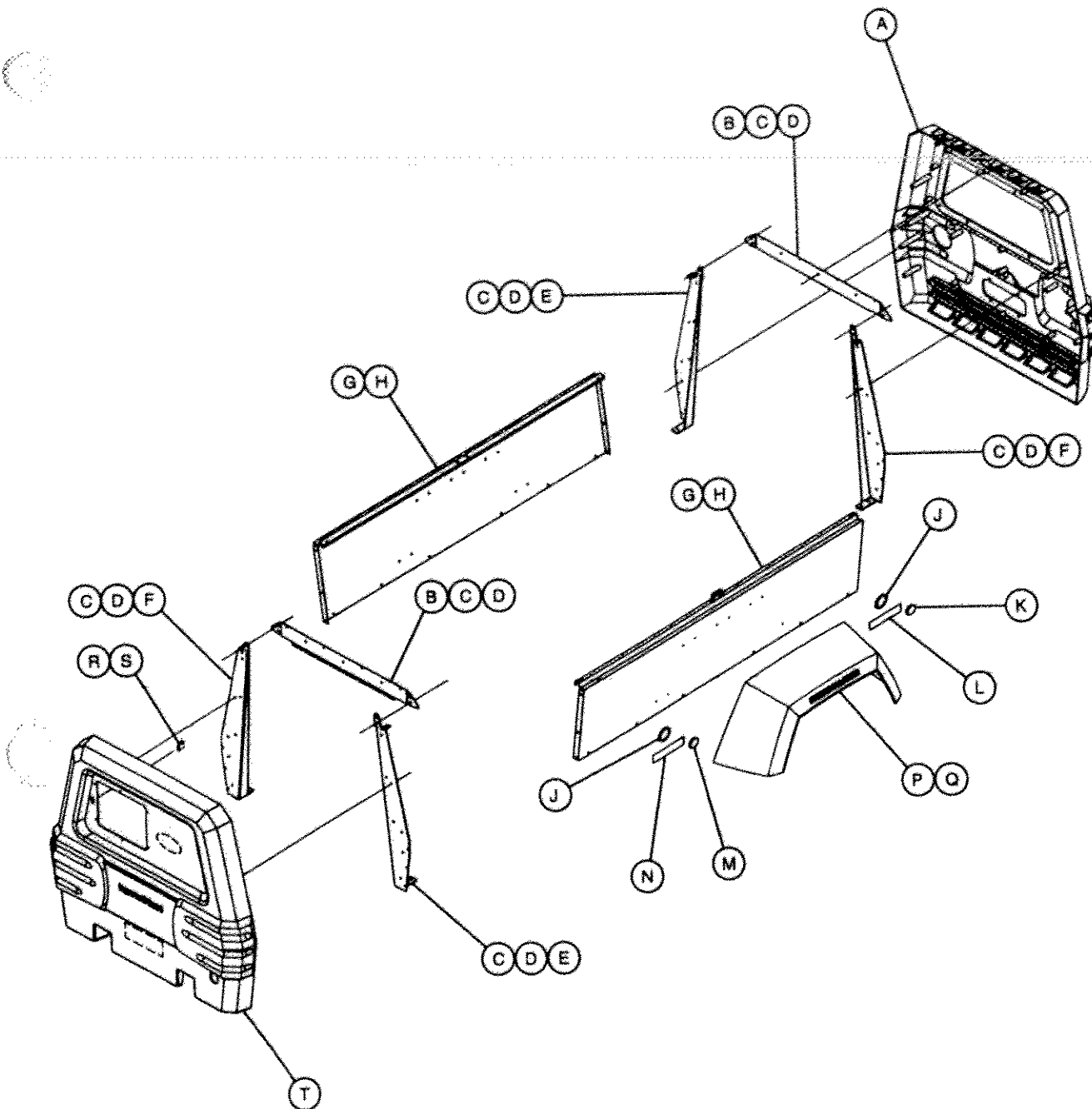

Item	CPN	Qty	Description	Item	CPN	Qty	Description
A	54473525	1	ENDCAP, REAR (STD. PAINT)	K	35367044	2	LIGHT, RED CLEARANCE
	54729140	1	ENDCAP, REAR (SPECIAL PAINT)	L	36894608	2	REFLECTOR, RED
B	54602719	2	CROSSMEMBER, ECAP	M	35367051	2	LIGHT, YELLOW CLEARANCE
C	35279025	16	SCREW, TAPPING M08-1.25 X 20	N	36894616	2	REFLECTOR, AMBER
D	54721238	22	SCREW, 11/32" HI-LO	P	36877579	2	FENDER
E	54631783	2	STIFFNER, PLASTIC ECAP	Q	92368687	10	SCREW, TAPPING M06-100 X 14
F	54631775	2	STIFFNER, PLASTIC ECAP	R	54721212	2	RIVET, 3/16 ALUMINUM
G	36894194	2	PANEL, SIDE	S	54482518	1	LATCH, PLASTIC ENDCAP (STD. PAINT)
	54529433	2	PANEL, SIDE (GALVANNEAL)		54729181	1	LATCH, PLASTIC ENDCAP (SPCL PAINT)
H	36797652	12	SCREW, TAPPING M06-100 X 12	T	54473517	1	ENDCAP, FRONT (STD. PAINT)
J	36893634	4	GROMMET, CLEARANCE LIGHT		54729132	1	ENDCAP, FRONT (SPECIAL PAINT)

ENCLOSURE COMPLETE (cont'd)

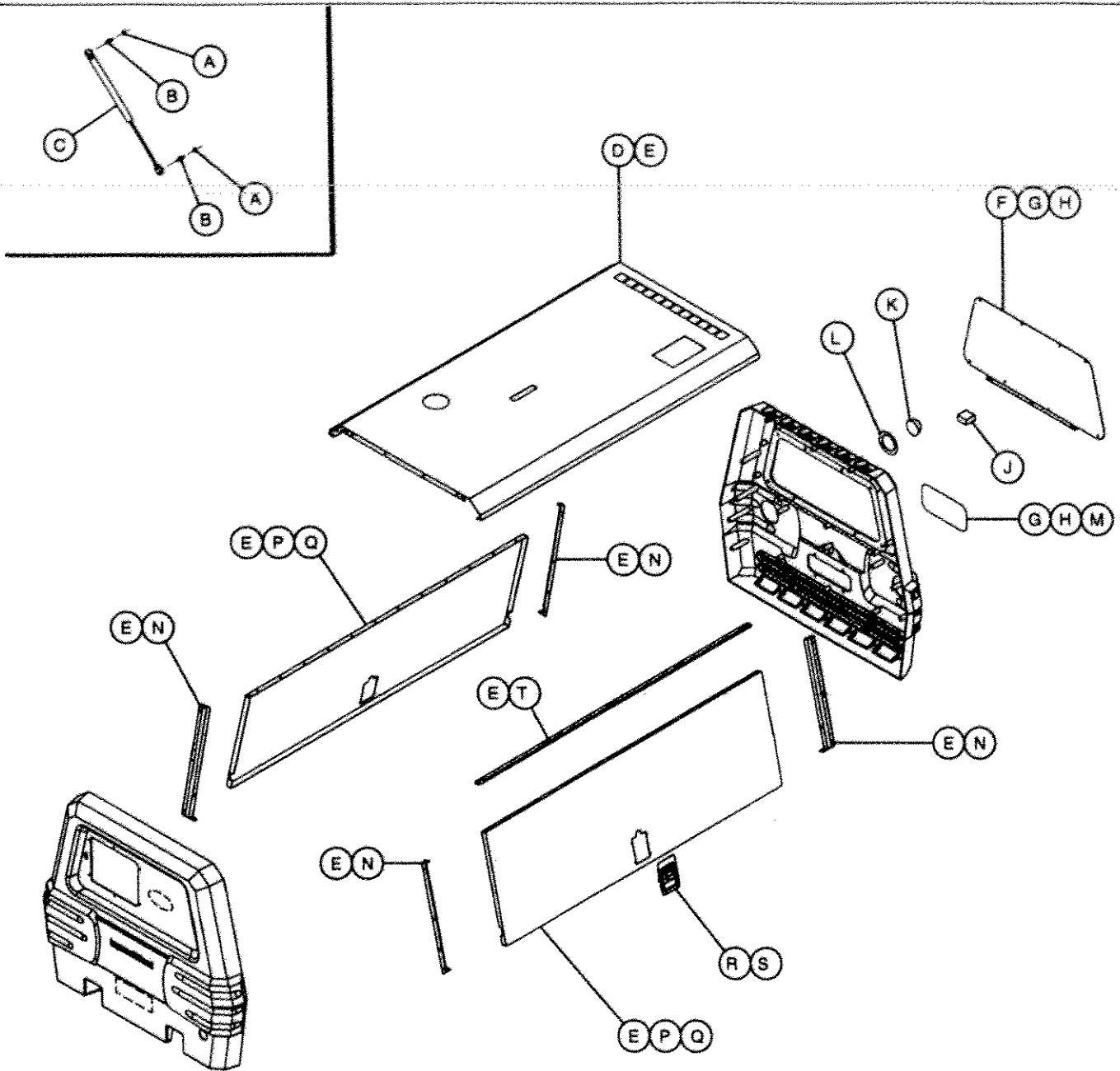





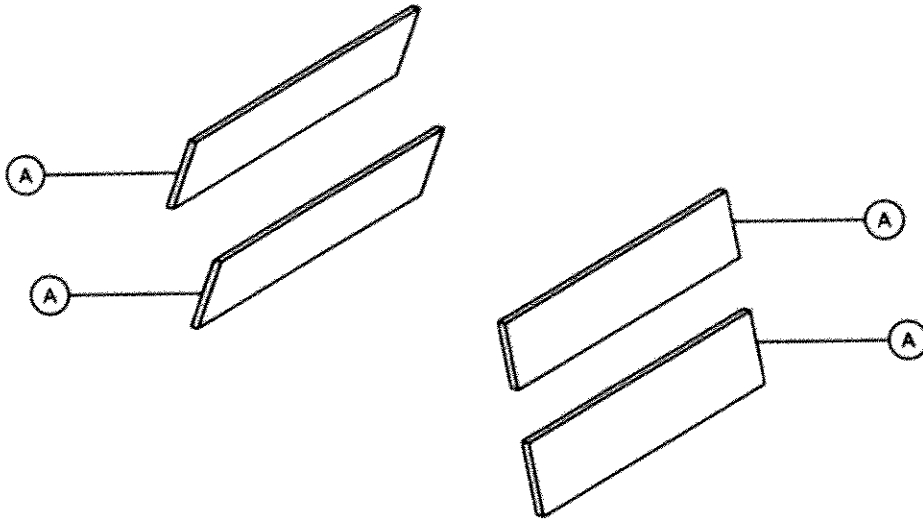



Item	CPN	Qty	Description	Item	CPN	Qty	Description
A	36881886	8	NUT, HEX FLANGE M08	L	36787968	2	GROMMET
B	35337328	8	STUD, BALL M08	M	36883452	1	COVER, COOLER ACCESS
C	35600287	4	SPRING, GAS		54529334	1	COVER, COOLER ACCESS (GALV)
D	22242358	1	ROOF, PANEL	N	36889558	4	STOP, DOOR
	22242382	1	ROOF, PANEL (GALV)		54529417	4	STOP, DOOR (GALV)
E	36797652	46	SCREW, TAPPING M06-100 X 12	P	36889509	2	DOOR
F	36883445	1	COVER, COOLER ACCESS		54529375	2	DOOR (GALV)
	54529326	1	COVER, COOLER ACCESS (GALV)	Q	36865293	6	BUMPER, RUBBER
G	54724117	12	GROMMET, SCREW	R	36793602	2	LATCH, SLAM DOOR
H	36885085	12	SCREW, TAPPING 1/4-10 X 3/4	S	36794816	8	RIVET, 3/16 X 1/8
J	54726468	1	LIGHT, LICENSE	T	36883437	2	HINGE, DOOR
K	36788081	2	LAMP ASSEMBLY				

# FOAM INSULATION COMPLETE





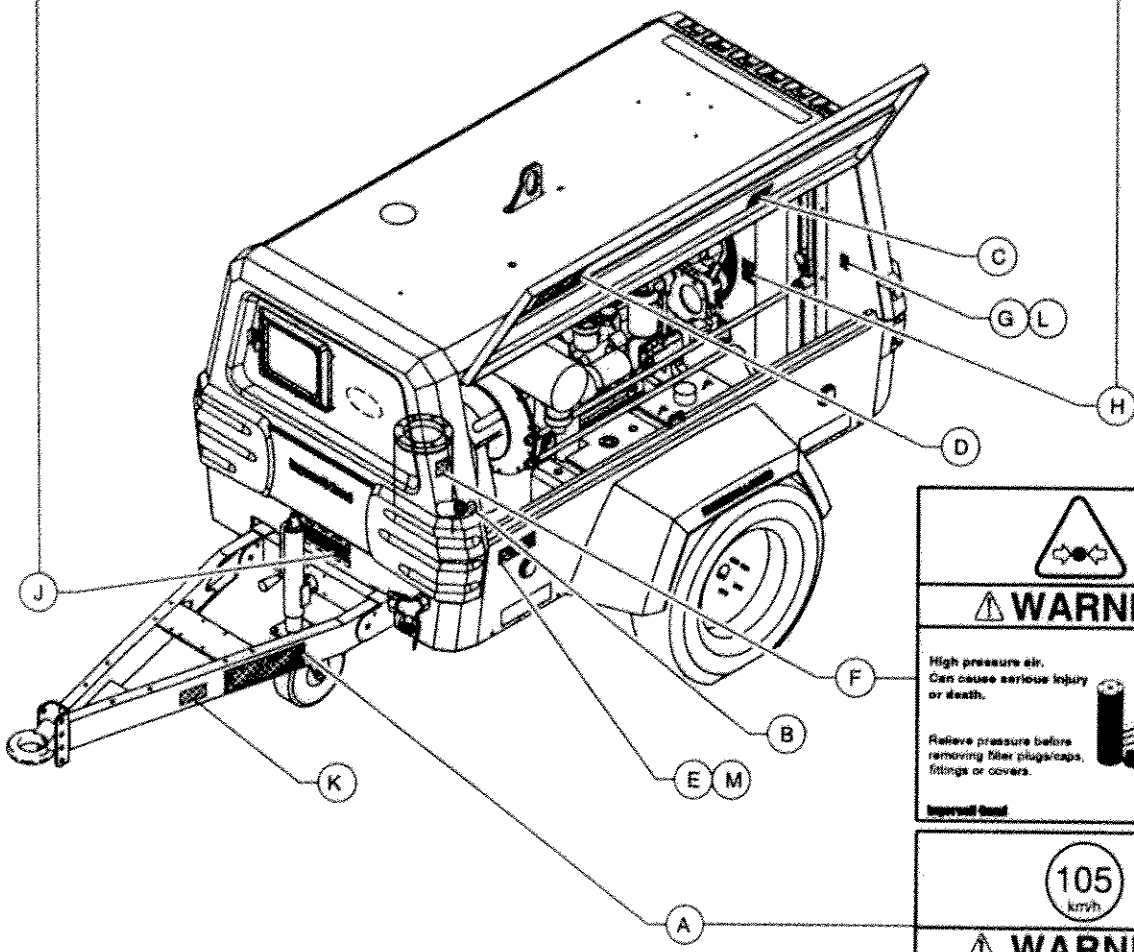

Item	CPN	Qty	Description
A	36883742	4	PANEL, SIDE DOOR ACST

ENCLOSURE COMPLETE (cont'd)

			
<b>⚠ DANGER</b>	<b>⚠ WARNING</b>	<b>⚠ WARNING</b>	<b>⚠ WARNING</b>
 <p>Discharged air can strike certain operators or other contributors. Will cause serious injury or death. Do not breathe the air.</p>	<p>Trapped air pressure. Can cause serious injury or death.</p>  <p>Close service valves and operate foot to vent trapped air before performing any service.</p>	<p>Decompressed air hoses with. Can cause serious injury or death.</p>  <p>When using air hose attach safety device (CO2A Valve) at source of air supply for each cut.</p>	 <p>Rotating fan blade. Can cause serious injury.</p> <p>Do not operate without guard in place.</p>





<b>⚠ WARNING</b>
<p>High pressure air. Can cause serious injury or death.</p>  <p>Relieve pressure before removing filter plugs/caps, fittings or covers.</p>

<b>⚠ WARNING</b>
 <p>Collapsing jockey stand. Can cause serious injury.</p> <p>Insert locking pin completely.</p>
 <p>Excessive towing speed. Can cause serious injury or death.</p> <p>Do NOT exceed 65 mph (105 km/h).</p>

Item	CPN	Description	Item	CPN	Description
A	54568803	2-PART DRAWBAR WARNING	G	36523306	SERIAL NUMBER PLATE
B	54604970	OIL FILL	H	54568779	ROTATING FAN WARNING
C	54625207	DIESEL FUEL	J	54629902	3-PART DANGER/WARNING
D	22318653	WIRING DIAGRAM	K	54604921	TOW CHAINS NOTICE
E	36531176	V.I.N.	L	36794816	RIVET
F	54568795	HIGH PRESSURE WARNING	M	36533081	V.I.N. OVERLAY

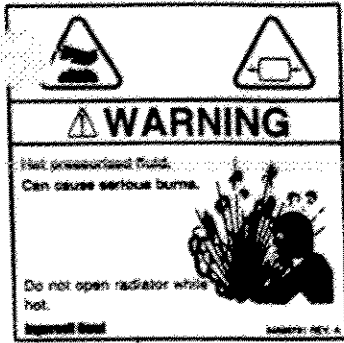
DECAL LOCATION (cont'd)



F

D

E

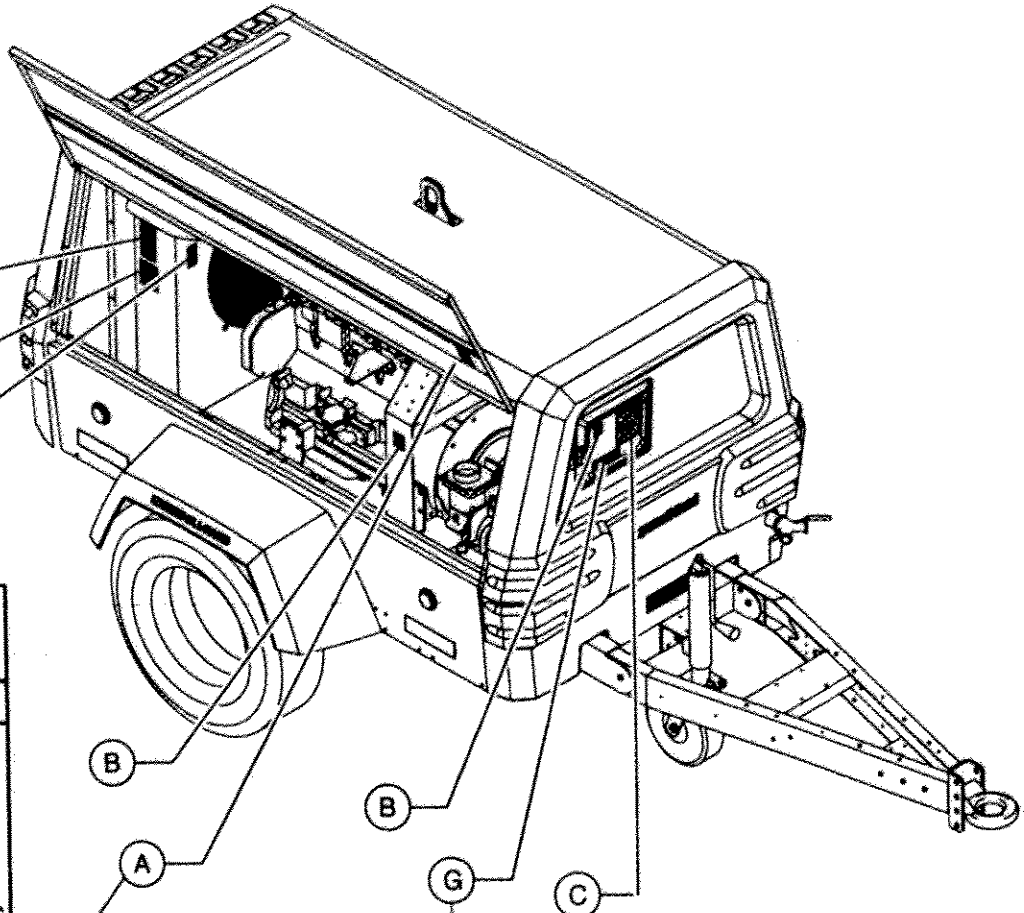

B

B

A

G

C

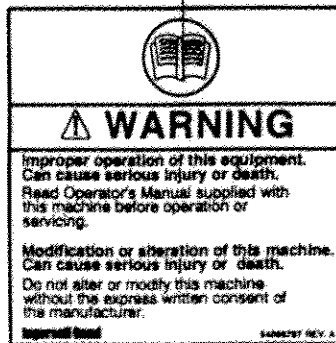

Item	CPN	Description
A	54568753	BATTERY GAS WARNING
B	54454756	NO ETHER
C	54749163	OPERATING INSTRUCTIONS
D	54804982	RADIATOR FILL
E	54568779	ROTATING FAN WARNING
F	54568761	HOT PRESS FLUID WARNING
G	54568787	IMPROPER OPERATION