



Portable Compressor Division
P. O. Box 868
Mocksville, NC 27028

OPERATING, MAINTENANCE, PARTS MANUAL

COMPRESSOR MODEL XHP900CM

Doosan purchased Bobcat Company from Ingersoll-Rand Company in 2007. Any reference to Ingersoll-Rand Company or use of trademarks, service marks, logos, or other proprietary identifying marks belonging to Ingersoll-Rand Company in this manual is historical or nominative in nature, and is not meant to suggest a current affiliation between Ingersoll-Rand Company and Doosan Company or the products of either.

Revised (01-13)

©INGERSOLL-RAND Co. 2001

**Revision A
07/2001**

QUALITY POLICY

We will supply products and services that consistently meet the requirements of our customers and each other.

TABLE OF CONTENTS

SECTION 1	SAFETY
SECTION 2	WARRANTY
SECTION 3	WARRANTY REGISTRATION
SECTION 4	SYSTEM DESCRIPTION
SECTION 5	INSTALLATION
SECTION 6	OPERATION
SECTION 7	GENERAL DATA
SECTION 8	MAINTENANCE/LUBRICATION
SECTION 9	PARTS ORDERING
SECTION 10	PARTS LIST
SECTION 11	COMMON FASTENERS
SECTION 12	DRAWINGS

SECTION 1 - SAFETY

IMPORTANT SAFETY INSTRUCTIONS



Look for these signs which point out potential hazards to the safety of you and others. Read and understand thoroughly. Heed warnings and follow instructions. If you do not understand, inform your supervisor.



(Red background)

Indicates the presence of a hazard which **WILL** cause severe injury, death or property damage, if ignored.



(Orange background)

Indicates the presence of a hazard which **CAN** cause severe injury, death or property damage, if ignored.



(Yellow background)

Indicates the presence of a hazard which **WILL** or **CAN** cause injury or property damage, if ignored.



(Blue background)

Indicates important setup, operating or maintenance information.

Never operate unit without first observing all safety warnings and carefully reading the operation and maintenance manual shipped from the factory with this machine.

DANGER

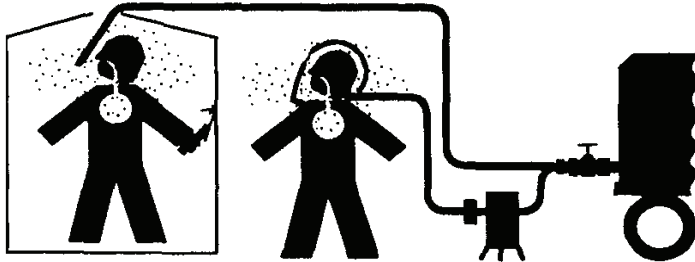

Air discharged from this machine may contain carbon monoxide or other contaminants which will cause severe injury or death. Do not breathe this air.

WARNING

Improper operation of this equipment CAN cause severe injury or death. Read Operator's Manual supplied with this machine before operation or service.

Modification or alteration of this machine CAN result in severe injury or death. Do not alter or modify this machine without the express written consent of the manufacturer.

WARNING

This machine produces loud noise with service valve vented. Extended exposure to loud noise can cause hearing loss. Always wear hearing protection when service valve is vented.

FREE SAFETY DECALS!

To promote communication of Safety Warnings on products manufactured by the Portable Compressor Division in Mocksville, N.C., Safety Decals are available **free** of charge. Safety decals are identified by the decal heading: **DANGER - WARNING or CAUTION.**

Decal part numbers are on the bottom of each decal and are also listed in the compressor's parts manual. Submit orders for Safety Decals to the Mocksville Parts Service Department. The no charge order should contain only Safety Decals. Help promote product safety! Assure that decals are present on the machines. Replace decals that are not readable.

WARNING

This machine produces loud noise with the doors open or service valve vented. Extended exposure to loud noise can cause hearing loss. Always wear hearing protection when doors are open or service valve is vented.

WARNING

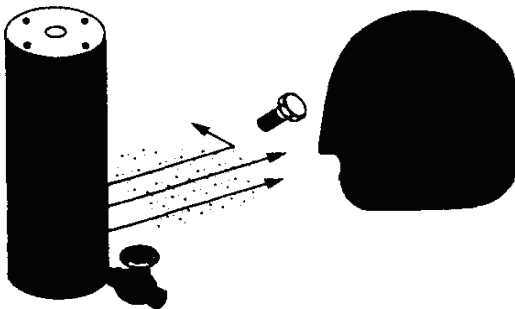

High pressure air.
Can cause severe injury or death.

Relieve pressure before removing
filler plugs/caps, fittings or covers.

WARNING

Never inspect or service unit without first relieving pressure from the air start reservoir to prevent accidental starting.

Do not remove the pressure cap from a HOT radiator. Allow radiator to cool down before removing pressure cap.

DANGER

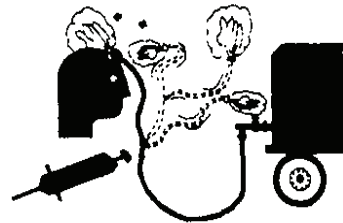

Disconnected Air Hoses Whip.
Can cause severe injury or death.

Always attach a safety flow restrictor
to each hose "at the source of supply
or branch line" in accordance with
OSHA Regulation 29CFR Section
1926.302(b).

DANGER

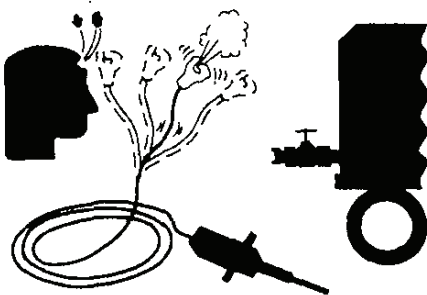

Air pressure can remain trapped in air
supply line which can result in
serious injury or death.

Always carefully vent air supply line
at tool or vent valve before
performing any service.

WARNING

Never run unit with guards, covers or screens removed. Keep hands, hair, clothing, tools, blow gun tips, etc. well away from moving parts.

WARNING

Do not use petroleum products (solvents or fuels) under high pressure as this can penetrate the skin and result in serious illness. Wear eye protection while cleaning unit with compressed air to prevent debris from injuring eye(s)

WARNING



**Hot pressurized fluid.
Can cause severe burns.**

Do not open radiator while hot.

CAUTION

Use extreme care to avoid contacting hot surfaces.
Air receiver and air discharge piping, etc.

Never allow the unit to sit stopped with pressure in
the receiver separator system. As a precaution,
open the service valve.

WARNING

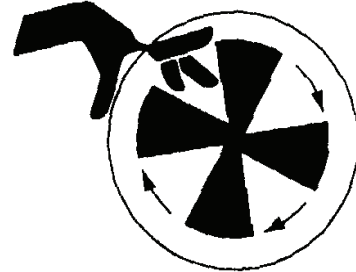

**Rotating fan blade.
Can cause severe injury.**

**Do not operate without guard in
place.**

CAUTION

Do not connect the air discharge on this unit onto a
common header with any other unit of any
description, or any other source of compressed air,
without first making sure a check-valve is used
between the header and the unit. If this unit is
connected with another unit, a safety hazard could
occur.

Hazardous Substance Precaution







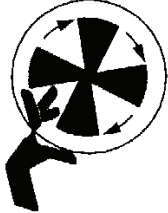

The following substances are used in the manufacture of this machine and may be hazardous to health if used incorrectly.

<i>SUBSTANCE</i>	<i>PRECAUTION</i>
<i>Compressor Oil</i>	<i>Avoid ingestion, skin contact and breathing fumes.</i>
<i>Preservative Grease</i>	<i>Avoid ingestion, skin contact and breathing fumes.</i>
<i>Rust Preventative</i>	<i>Avoid ingestion, skin contact and breathing fumes.</i>

**INGERSOLL-RAND®
AIR COMPRESSORS**

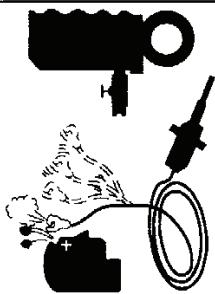
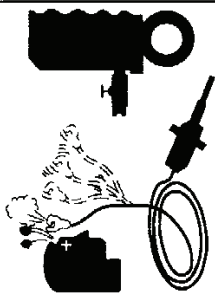
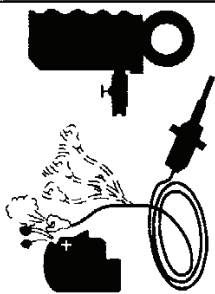
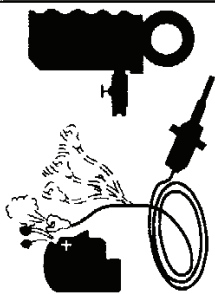
**PORTABLE COMPRESSOR
SAFETY CARD**

⚠ DANGER	DANGER indicates an imminently hazardous situation which, if not avoided, WILL result in DEATH or SERIOUS INJURY.
⚠ WARNING	WARNING indicates a potentially hazardous situation which, if not avoided, COULD result in DEATH or SERIOUS INJURY.
⚠ CAUTION	CAUTION indicates a potentially hazardous situation which, if not avoided, MAY result in MINOR or MODERATE INJURY.

⚠ DANGER		⚠ WARNING	
Discharged air can contain carbon monoxide or other contaminants. Will cause serious injury or death. Do not breathe this air. <i>This decal/near service valve.</i>		Improper operation of this equipment. Can cause serious injury or death. Read Operator's Manual supplied with this machine before operation or service.	
⚠ WARNING		⚠ WARNING	
			
Disconnected air hoses whip. Can cause serious injury or death. When using air tools attach safety device (OSHA Valve) at source of air supply for each tool. <i>This decal/near service outlet.</i>		Combustible gas. Can cause serious burns, blindness or death. Keep sparks and open flames away from batteries. <i>This decal/near battery.</i>	
			
Trapped air pressure. Can cause serious injury or death. Close service valve and operate tool to vent trapped air before performing any service. <i>This decal/near service outlet.</i>		Rotating fan blade. Can cause serious injury. Do not operate without guard in place. <i>This decal/near fan.</i>	
			
High pressure air. Can cause serious injury or death. Relieve pressure before removing filler plugs/caps, fittings or covers. <i>This decal/near receiver tank.</i>		⚠ WARNING	
Safety Labels shown on this Card and on the machine are for operator and/or other personnel protection. Replacement Safety Labels can be obtained at no cost from your local Ingersoll-Rand dealer or representative or by contacting the factory at Ingersoll-Rand Co. P.O. Box 868 Mocksville, NC 27028			

⚠ WARNING

Hot pressurized fluid. Can cause serious burns. Do not open radiator while hot. *This decal/near radiator cap.*

© Ingersoll-Rand 1999

3652290 REV. N

SECTION 2 - WARRANTY

Ingersoll-Rand, through its distributor, warrants that each item of equipment manufactured by it and delivered hereunder to the initial user to be free of defects in material and workmanship for a period of three (3) months from initial operation or six (6) months from the date of shipment to the initial user, whichever first occurs.

With respect to the following types of equipment, the warranty period enumerated will apply in lieu of the foregoing warranty period.

Aftercoolers, Drill Mountings and Klemm Rotary Heads - The earlier of six (6) months from initial operation or nine (9) months from date of shipment to the initial user.

Portable Compressors, Portable Generator Sets (GENSET), Portable Light Towers and Abrasive Blasting Equipment - The earlier of twelve (12) months from shipment to, or the accumulation of 2,000 hours of service by, the initial user.

All Compressor Air Ends, GENSET Generators and Paving Breakers - The earlier of twenty-four (24) months from shipment to, or the accumulation of 4,000 hours of service by, the initial user. For Air Ends, the warranty against defects will include replacement of the complete Air End, provided the original Air End is returned assembled and unopened.

Pavers, Milling Machines, Pedestrian Compactors (including baseplates, upright and walk behinds) and Rotary Drills - The earlier of (6) months from shipment to, or the accumulation of 1,000 hours of service by, the initial user.

Jackhammers, Forklifts and Self-Propelled Compactors - The earlier of twelve (12) months from shipment to, or accumulation of 1,000 hours of service by, the initial user.

Downhole Drills - In lieu of the repair or replacement of defective parts, Ingersoll-Rand may elect to issue full or partial credit toward the purchase of a new part. The extent of credit issued will be determined by pro rating against the normal service life of the part in question.

Spare Parts (excluding downhill drills) - Three (3) months from date of shipment.

Warranty

Ingersoll-Rand will provide a new part or repaired part, at its election, in place of any part which is found upon its inspection to be defective in material and workmanship during the period prescribed above. Such part will be repaired or replaced without charge to the initial user during normal working hours at the place of business of an Ingersoll-Rand distributor authorized to sell the type of equipment involved or other establishment authorized by Ingersoll-Rand. User must present proof of purchase and date at the time of exercising warranty.

This warranty does not apply to failures occurring as a result of abuse, misuse, negligent repairs, corrosion, erosion and normal wear and tear, alterations or modification made to the product without express written consent of Ingersoll-Rand; or failure to follow the recommended operating practices and maintenance publications.

Accessories or equipment furnished by Ingersoll-Rand, but manufactured by others, including, but not limited to, engines, tires, batteries, engine electrical equipment, hydraulic transmissions, carriers, shall carry whatever warranty the manufacturers have conveyed to Ingersoll-Rand and which can be passed on to the initial user.

This warranty is in lieu of all other warranties (except of title), expressed or implied, and there are no warranties of merchantability or of fitness for a particular purpose.

Limitation of Liability

The remedies of the user set forth under the provisions of warranty outlined above are exclusive and the total liability of Ingersoll-Rand or its distributors with respect to this sale, delivery, installation, repair or technical direction covered by or furnished under this sale whether based on contract, warranty, negligence, indemnity, strict liability or otherwise shall not exceed the purchase price of the unit of equipment upon which such liability is based.

Ingersoll-Rand, its supplier(s) and its distributors shall in no event be liable to the user, any successors in interest or any beneficiary or assignee relating to this sale for any consequential, incidental, indirect, special or punitive damages arising out of this sale or any breach thereof, or any defects in, or failure of, or malfunction of the equipment under this sale whether based upon loss of use, lost profits or revenue, interest, lost goodwill, work stoppage, impairment of other goods, loss by reason of shutdown or non-operation, increased expenses of operation of the equipment, cost of purchase of replacement power or claims of users or customers of the user for service interruption whether or not such loss or damage is based on contract, warranty, negligence, indemnity, strict liability or otherwise.

General Warranty Information

PRODUCT	PACKAGE	AIREND	GENERATOR
Portable Compressor	1 yr/2000 hrs.	2 yr/4000 hrs.	_____
Portable Genset	1 yr/2000 hrs.	_____	2 yr/4000 hrs.
(20-50 KW)		_____	
Light Tower	1 yr/2000 hrs.	_____	1 yr/2000 hrs.
Aftercooler	6 months	_____	_____
Abrasive Blast Equipment	1 year	_____	_____

**PRODUCT
WARRANTY**

MANUFACTURER	MONTHS	HOURS	EXTENDED COVERAGE
Caterpillar	12	no limit	Available @ Dealer
Cummins	12	no limit	Available @ Dealer major components
in service after 1 Feb 93	12/24	no limit/2000	2 yrs/10000 hrs.
John Deere	24	2000	Available @ Dealer
Deutz	12	no limit	Available @ Dealer
Ford	12	2000	_____
Honda	24	no limit	_____
Kubota	24	2000	major components 25-36 mo/3000 hrs parts only
Vanguard	24	no limit	_____
White	12	2000	

**ENGINE
WARRANTY**

MANUFACTURER	MONTHS	HOURS	COMMENTS
Ingersoll-Rand	3	no limit	parts only

**PARTS
WARRANTY**

AIREND TYPE	MONTHS	HOURS	COMMENTS
Vane	6	1000	parts & labor
Screw	12	2000	parts & labor

**AIREND
EXCHANGE
WARRANTY**

SECTION 3 - WARRANTY REGISTRATION

Complete Machine Registration

Machines shipped to locations within the United States do not require a warranty registration unless the machine status changes (i.e. change of ownership).

Machines shipped outside the United States require notification be made to initiate the machine warranty.



Fill out the Warranty Registration Form in this section, keep a copy for your records and mail form to:

Ingersoll-Rand Company
Portable Compressor Division
P.O. Box 668
Mocksville, North Carolina 27028

Attn: Warranty Department

Note: Completion of this form validates the warranty.

Engine Registration:

No engine registration required. Must present Proof of Purchase whenever engine warranty service is required.

INGERSOLL-RAND®

Warranty Registration Form

Completion of this form validates the warranty

AIR COMPRESSORS

Selling Distributor	Servicing Distributor	WARRANTY REGISTRATION	
Name _____	Name _____	Owner/User Name _____	
Address _____	Address _____	Address _____	
City _____	City _____	City _____	
County _____	County _____	County _____	
State _____	State _____	State _____	
Zip Code _____	Zip Code _____	Zip Code _____	
Telephone _____	Telephone _____	Telephone _____	

Complete the Applicable Blocks
Owner/User Type of Business (check one only)

<input type="checkbox"/> Construction-Heavy (highway, excavation, etc.)	<input type="checkbox"/> Asphalt Contractor	<input type="checkbox"/> Coal Mining	<input type="checkbox"/> Other Mining
<input type="checkbox"/> Construction-Light (carpentry, plumbing, pools mason, etc.)	<input type="checkbox"/> Government (municipal, state, county, etc.)	<input type="checkbox"/> Quarry	<input type="checkbox"/> Shallow Oil & Gas
<input type="checkbox"/> Rental (rental center, rental fleet, etc.)	<input type="checkbox"/> Building Contractor	<input type="checkbox"/> Waterwell	<input type="checkbox"/> Utility Company (gas, electric, water, etc.)
<input type="checkbox"/> Industrial (plant use)	<input type="checkbox"/> Other specify _____	<input type="checkbox"/> Exploration	<input type="checkbox"/> Utility Contractor

Model	Unit S/N	Engine S/N	Date Delivered
_____	_____	_____	_____
Unit-Hours	Airend S/N	Truck S/N	Truck Engine S/N
_____	_____	_____	_____

SERVICING DISTRIBUTOR/USER ACKNOWLEDGMENT

- 1 The Purchaser has been instructed and/or has read the manual and understands proper preventative maintenance, general operation and safety precautions.
- 2 The warranty and limitation of liability has been reviewed and understood by the owner/user.
- 3 In the event that this unit is to be used within a nuclear facility, the owner/user shall notify Ingersoll-Rand of such use so that Ingersoll-Rand may arrange for appropriate nuclear liability protection from the owner-licensee of the facility.
- 4 Ingersoll-Rand reserves the right to make design changes or modifications of Ingersoll-Rand products at anytime without incurring any obligation to make similar changes or modifications on previously sold units.

I hereby acknowledge acceptance of above.

Owner/User _____ Date _____

I hereby certify that the above is accurate and complete.

Distributor/I-R Rep. _____ Date _____

Attention: Warranty Department
Ingersoll-Rand Company
Portable Compressor Division
P. O. Box 868
Mocksville, NC 27028

----- *fold* -----

SECTION 4 – SYSTEM DESCRIPTION

General

The CM air compressors are semi-packaged, air cooled units designed for power take-off applications. Each unit is designed to operate at ambient temperatures from - 10°F to 125°F (-23.3°C to 51.7°C). For the actual delivery of each unit at its rated operating pressure, refer to the typical General Data Decal supplied with each unit, and to the table in Section 5.

The unit includes an oil flooded, rotary, screw-type air compressor, a compressor inlet system, a capacity control system, a compressor lubricating oil system, a compressor discharge system as well as basic instrumentation. The compressor inlet system includes two air intake cleaners with a service indicator. The capacity control system includes a pressure regulator linked to a compressor inlet butterfly valve. The compressor lubricating oil system includes an air-cooled type oil cooler, two oil filters, and oil control valve and an oil separator tank and air receiver. The oil cooler is of the fin and tube-type construction that requires forced draft cooling air. Basic instrumentation includes compressor discharge air pressure and temperature gauges, and air cleaner restriction indicator.

The enclosure cabinet, in which most of the components are mounted, is of heavy gauge sheet steel and is equipped with easy opening access panels for performing routine maintenance functions.

Compression in the screw-type air compressor is created by the meshing of two sets of helical rotors (male and female) on parallel shafts enclosed in heavy-duty cast iron housings with air inlet and outlet ports located at opposite ends. The air end is a two-stage type. Air is compressed to an intermediate pressure by the first stage. The discharge of the first stage empties into the inlet of the second stage, where compression to the final discharge pressure is accomplished. The male rotors have four lobes, 90 degrees apart and the female rotors have six grooves 60 degrees apart. The grooves of the female rotor mesh with and are driven by the male rotor. Thrust taper roller bearings at the rear of the air end prevent longitudinal movement of the rotors. As rotation of the compressor occurs, the rotors unmesh and free air is drawn into the cavities or pockets between the male rotor lobes and the grooves of the female rotor. The air is trapped in these pockets and follows the direction of rotation of each rotor. As soon as the inlet port is closed, the compression cycle begins and the trapped air is directed to the opposite or discharge side of the rotor housing. As the rotors mesh, the normal free volume of air is decreased and the pressure increased until the closing pocket reaches the discharge port, (or in the case of the first stage, the interstage cavity). Cooled lubricating oil is admitted to the compressor by being injected, in metered amounts, directly into the rotor housing so that it passes on with the air being compressed. This removes the heat of compression to a large degree and results in a relatively low, final discharge air temperature.

Since the CM Series compressor is of the positive displacement type, an air flow control system must be provided to regulate the volume of air passing through the compressor to match the amount of service air required by the customer.

Constant speed control unloads the compressor at a predetermined pressure while the driving unit continues to operate at full speed. This is accomplished by an air operated regulator closing off the intake to the compressor in an infinitely variable or stepless manner through the inlet butterfly valve.

The discharge air pressure can be controlled between 150 and 350 psig (1034 to 2413 kPa) by simple readjustment of the pressure regulator adjusting screw.

SECTION 5 - INSTALLATION

Location

After the type of drive is determined, satisfactory installation depends upon the ability of the installer. Refer to the appropriate foundation plan located in the back of this manual for the dimensions of the compressor package and the appropriate separator foundation plan for the dimensions of the combination primary oil separator tank-air receiver (hereafter called the receiver separator).

Choose a clean, relatively cool location for the compressor package, and provide ample space around the unit for general accessibility and to ensure effective heat dissipation. Extreme care must be taken in locating an air-cooled unit of this type so there is an unrestricted supply of air to the cooling fan, which pulls air over the oil cooler core. The fan discharge air must flow away from the unit so that it may be readily dissipated to atmosphere without recirculating hot air to the fan intake. Any recirculation of the cooling air may result in an excessively high compressor operating temperature. The compressor package must be located so the compressor discharge temperature gauge and the air cleaner service indicator will be fully visible. Included with the compressor package is a compressor discharge pressure gauge and a discharge temperature gauge.

For the installation of the receiver separator, choose a location that is on the same level as or lower than the compressor package. Ample space must be provided around the receiver to ensure the proper installation of all piping connections. In addition, the receiver separator must be located so that the separator element may be removed for inspection and service. Refer to the appropriate separator foundation plan.

A condensate drain valve is factory supplied with the receiver separator. When installing the receiver separator, provision should be made for easy access to this drain valve as it will be necessary to drain the condensate daily before starting the unit.

NOTE

The condensate drain valve and line must be located as the lowest point in the lubricating and cooling oil system for proper condensate removal.

The valve may also be used as a service valve for draining the lubricating and cooling oil at periodic change intervals.

Exact level is not absolutely necessary, but it is recommended the unit be leveled with a sight glass or a carpenter's level set on the compressor housing. Leveling may be accomplished by shimming the unit near the unit's bolting holes. Be sure to use steel shims. Mounting holes are provided on the bottom of the base and weld nuts are provided on the sides of the frame. Either may be used for mounting.

Inlet Piping

Each unit is supplied with standard air cleaners to protect the compressor from normal air-borne dust and dirt. If necessary, the air cleaners may be removed and remotely mounted for ease in accessibility.

PIPING

General

As CM Series compressors are comprised of two modules (compressor and separator), there is necessarily interconnecting piping between the two. These hoses are not provided with the units, as the required lengths of the hoses are dependent on the relative location of the two modules in their installed location. It is left to the installer to obtain hoses of the correct type and length for each installation.

The following hoses will be needed:

LOCATION	SIZE	HOSE TYPE
Compressor Module to Separator Scavenge	-6 JIC	Parker-Hannifin 213, or Aeroquip FC350, or equivalent
Compressor Module to Air Pressure Regulator Outlet	-6 JIC	Parker-Hannifin 213, or Aeroquip FC350, or equivalent
Compressor Module to Separator Discharge	-12 JIC	Parker-Hannifin 213, or Aeroquip FC350, or equivalent
Oil Cooler to Separator Oil Outlet	-24 JIC	Parker-Hannifin 213, or Aeroquip FC350, or equivalent
Airend Discharge to Receiver/Separator Inlet	3" Hose Stem	Dana/Boston Blackjack Hose IR P/N 43203876

NOTES:

1. All hoses terminate at marked bulkhead fittings on the left side of machine
2. All hoses terminate in Type I (SAE J516 female swivel straight), 37° JIC flare fittings on each end.
3. Airend discharge pipe is customer supplied.

Compressor Discharge Piping

The connection between the compressor package and the receiver separator must be furnished by the customer. It is recommended the customer use a flexible line with an inside diameter of the same size, or larger than the compressor package discharge connection. All piping must be certified safe for the pressures and temperatures involved.

Receiver separator Discharge Piping

The receiver separator discharge piping must be furnished by the customer. Refer to the appropriate separator fitting location for a typical piping arrangement for these units. A minimum pressure valve and a manual shut-off valve is supplied with each unit and must be piped into the customer's system as indicated. The minimum pressure valve is supplied to maintain approximately 125 psig (862 kPa) in the air receiver tank to ensure proper oil circulation and also to prevent excessive oil carryover into the customer's air service system. The manual shut-off valve must be installed between the minimum pressure valve and the customer's air service system to serve as an isolation valve.

In addition, whenever this unit is connected to a high volume customer's service air system, a terminal check valve must also be installed downstream of the minimum pressure valve and the isolation valve to prevent air from the system from bleeding back into the compressor system on shutdown.

Wiring

The compressor is protected against overheating by a thermal-type discharge air temperature switch located in the compressor discharge piping. A "normally-closed" type thermal switch, factory set at 248°F (120°C), is supplied as standard equipment on these units. This switch is supplied for 12/24 volt DC. As an option, this switch may be supplied for 125 volt AC. A thermal sensor switch, also set at 248°F (120°C), normally closed, is provided as extra protection in the receiver separator. It is to be wired in series with the airtend temperature switch by the user and then into the end user's shutdown system. The end user's system must be capable of initiating shutdown of the driver engine within 3-5 seconds of opening of either of the shutdown switches. This switch is supplied for 12/24 volts DC, with optional AC switches available as an option.

Driver

The installation of a CM Series Compressor with any drive such as a power take-off drive or a hydraulic motor drive is very flexible. The proper rotation of the compressor is clockwise when viewed from the driver end.

NOTE

Because the compressor is of the axial screw type, the rotation cannot be changed.

MODEL	CAPACITY		TORQUE REQUIRED		POWER REQUIRED		INPUT
	CFM	M ³ /MIN.	POUND - FEET	N·M	BHP	KILOWATTS	RPM
XHP900	900	25.4	1152	1563	395	294	1800

Note: Power requirements include fan.

A drive shaft from the source of power take-off is used to drive the compressor. It is extremely important that the angularity of the drive shaft, including the universal joints, be within the limits specified by the manufacturer. The power take-off shaft and the compressor rotor drive shaft must always be parallel. This gives the same angle at each universal joint and prevents excessive wear. The forks of the universal joint on the drive end must be installed parallel to the forks on the driven end universal. There are many types of universal joints that can be used. However, a constant velocity universal joint as previously described will reduce the possibility of torsional vibration. If a slip joint or spline is used on the drive system, it should be placed between the two universal joints for best results.

It is NOT permissible to directly belt drive this unit, or use any configuration of drive that puts side load on the compressor drive shaft. Belt or other side loads must be supported by external bearings.

Regulation

The standard regulation system supplied with CM Series Compressors is designed to provide capacity control for the compressor only. Variable speed control of a driver engine is possible with additional equipment. Consult Ingersoll-Rand Company, Specialty Products Department for technical assistance for these applications.

The adjustment and operation of the standard regulation system is described in Section 6, Operating Instructions.

SECTION 6 - OPERATING INSTRUCTIONS

SETTING-UP

- Place the unit in an open, well-ventilated area. Position as level as possible. The design of these units permits a 15 degree limit on out-of-level operation.
- When the unit is to be operated out-of-level, it is important to have the compressor oil level gauge show no more than mid-scale (with the unit running at full load). Do not overfill either the engine crankcase or the compressor lubricating oil system.

PROCEDURE FOR AIREND OIL PRIMING

(TO BE PERFORMED PRIOR TO INITIAL START-UP)

AIREND SIZE	QUANTITY OF OIL INJECTED (GALLONS/LITERS)	
	METHOD A	METHOD B
85MM	0.5 / 2	1.0 / 4
CF75	0.5 / 2	1.0 / 4
100MM	0.5 / 2	1.0 / 4
CF90	0.5 / 2	1.0 / 4
127.5MM	0.5 / 2	1.0 / 4
178.5MM	1.0 / 4	2.0 / 8
226MM	1.8 / 7	3.6 / 14
285MM	3.0 / 11	6.0 / 23
350MM	4.0 / 15	8.0 / 30

Notes:

- All airends are to be primed with oil before the first start of the unit. The prime oil quantity is part of the total fill quantity of the unit.

The priming of single stage airends can be done by either of the two following methods:

- Disconnect main oil supply hose that goes from the oil filter outlet to the airend and inject oil directly into this hose to the airend.
- Disconnect the separator tank scavenge hose that leads to the oil filter and inject oil into the filter.

- The chart shows minimum fill requirements.

- HR2: Disconnect the hose going to the seal and inject 7 gallons (26L) into the manifold tubing.

–HR2.5: Remove cap on manifold tube between pump and filter and inject 7 gallons (26L) into the manifold tubing.

BEFORE STARTING

CAUTION

Do not connect the air discharge on this unit into a common header with any other unit of any description, or any other source of compressed air, without first making sure a check valve is used between the header and the unit. If this unit is connected in parallel with another unit of higher discharge pressure and capacity, a safety hazard could occur in a back-flow condition.

Safety valve setting is 425 psig (2930 kPa). Assure external air system is safe under all operating conditions to prevent serious hazard to operations personnel.

WARNING

Unrestricted air flow from a hose will result in a whipping motion of the hose which can cause severe injury or death. A safety device must be attached to the hose at the source of supply to reduce pressure in case of hose failure or other sudden pressure release. Reference: OSHA regulation 29 CFR Section 1926.302 (b).

- Open manual blow-down valve to ensure pressure is relieved in receiver separator system. Close valve in order to build up full air pressure and ensure proper oil circulation.

- Check the compressor lubricating oil level. The proper oil level is mid-way on the sight gauge. Add oil if the level falls to the bottom of the sight gauge. Do not overfill.

WARNING

This machine produces loud noise. Extended exposure to loud noise can cause hearing loss. Wear hearing protection when valve(s) are open.

Be sure no one is IN or ON the compressor unit.

Do NOT operate machine with guards removed.

Do NOT operate machine with any access panel open. Unit will quickly overheat.

CAUTION

Do NOT operate machine with safety shutdown switches bypassed.

STARTING/OPERATING

- Close service valve.
- Engage main driver.
- Allow compressor to run unloaded five (5) to ten (10) minutes.
- Compressor is now ready to furnish compressed air when service valve is opened.

STOPPING

- Close air service valve(s).
- Allow the unit to run at "no load" for 3 to 5 minutes to reduce the compressor temperature.
- Disengage main driver.

NOTE: Once the drive motor stops, the automatic blow-down valve will begin to relieve all pressure from the receiver separator system.

CAUTION

Never allow the unit to sit stopped with pressure in the receiver separator system. As a precaution, after the automatic blow-down period (2 minutes), open the manual blow-down valve.

EQUIPMENT PROTECTION

NOTE: Do NOT wire around or bypass a shutdown sensor or switch.

This unit is protected by two (2) shutdown switches at the following locations:

High Discharge Air Temperature-

- (1) At the airend outlet.
- (2) In the safety valve connection on the separator tank.

GAUGE PANEL

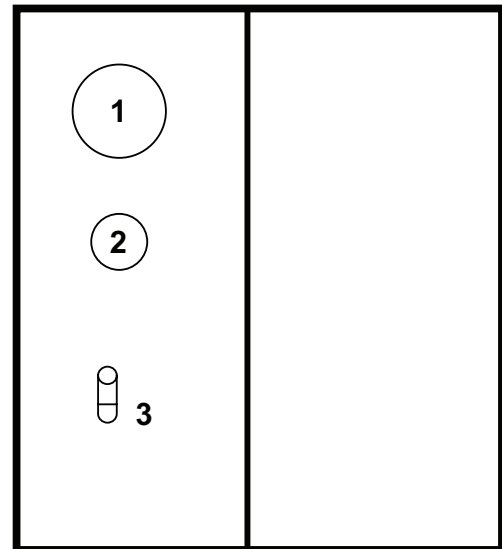

Operating Instruments

1. Compressor Discharge Pressure Gauge

Indicates pressure in receiver tank, psig (kPa).

2. Discharge Air Temp. Gauge

Indicates discharge air temperature in °F and °C.
Normal operating range: 185°F/85°C to 248°F/120°C.

3. Air Filter Restriction Indicator

Indicates compressor air cleaner restriction.
Normal operation (<20 in. H₂O), green flag
Needs service (≥20 in. H₂O), red flag.

Pressure Regulation Adjusting Instructions

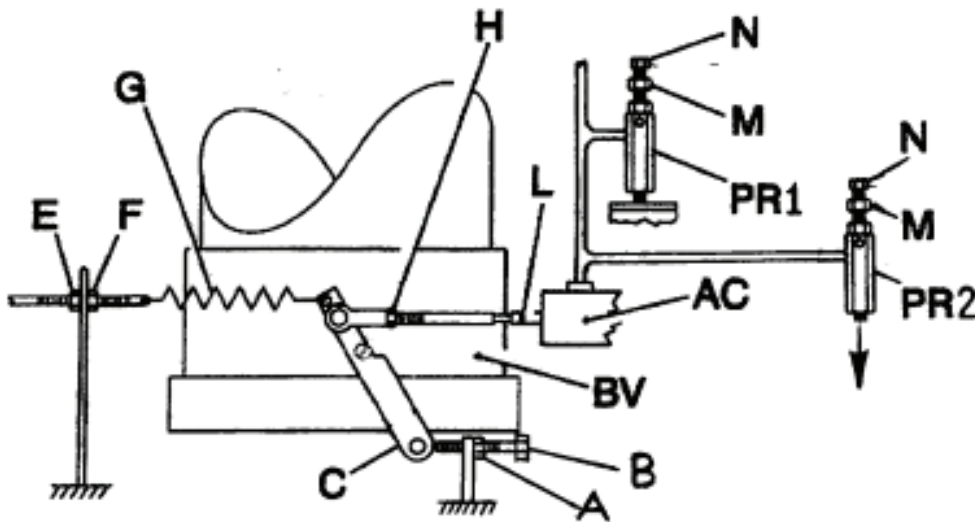

Adjustment Instructions

The operating pressure of this unit was set at the factory to the maximum rating (at full speed) See General Data. However, this pressure may be reset down to 160 psi (1050 kPa)

Normally, regulation requires no adjusting; but if proper adjustment is lost, proceed as follows:

1. Loosen nut A. Adjust Stop bolt B until scribe mark on end of BV shaft is 60° above horizontal. Re-tighten A.
2. Loosen nut (E) to relax spring (G).
3. Loosen nut (H). Turn rod (L) in Air Cylinder (AC) until there is approximately 3/4 inch (20 mm) between nut (H) and flats on rod (L).
4. Turn rod (L) one round into rod end bearing. Tighten nut (H). Rotate butterfly shaft/lever (C), open and close, several times to assure that linkage is not binding.
5. Take slack out of spring (G) by moving nuts (E) and (F). Tighten nuts.
6. Start unit and allow to warm up for 3 to 5 minutes.
7. Activate "Service Air" switch if so equipped.
8. With service air valve closed, adjust pressure regulator (PR) to rated pressure (*) plus 10 psi (70kPa) as follows:
9. Loosen locknut (M) counterclockwise. Turn adjustment cap (N) clockwise to increase pressure, counterclockwise to decrease pressure.
10. Bring driver engine to rated speed.
11. Open service air valve until lever C contacts stop B. Adjust regulator to give rated operating pressure (*). Tighten locknut (M).
12. To regulate to any pressure between 150 psi (1050kPa) and maximum rating (*), make adjustments at the pressure regulator.
13. Note: For Dual Regulation –
Unit may be equipped with dual regulation. This includes a second pressure regulator (PR2) set at a lower pressure than the PR1. **Setting of the PR2 must be between 150 and 250 psig.** Repeat steps 9-12 to set PR2 after selecting low pressure range on customer panel. Any override needle valve must be closed during this procedure.

TROUBLESHOOTING

INTRODUCTION

Troubleshooting for a portable air compressor is an organized study of a particular problem or series of problems and a planned method of procedure for investigation and correction. The troubleshooting chart that follows includes some of the problems that an operator may encounter during the operation of a portable compressor.

The chart does not attempt to list all of the troubles that may occur, nor does it attempt to give all of the answers for correction of the problems. The chart does give those problems that are most apt to occur. To use the trouble shooting chart:

- A. Find the "complaint" depicted as a bold heading.
- B. Follow down that column to find the potential cause or causes. The causes are listed in order (1,2,3 etc.) to suggest an order to follow in trouble shooting.

ACTION PLAN

A. Think Before Acting

Study the problem thoroughly and ask yourself these questions:

- (1) What were the warning signals that preceded the trouble?
- (4) If the compressor will still operate, is it safe to continue operating it to make further checks?

- (2) Has similar trouble occurred before?
- (3) What previous maintenance work has been done?

B. Do the Simplest Things First

Most troubles are simple and easily corrected.

Always check the easiest and most obvious things first; following this simple rule will save time and trouble.

C. Double Check Before Disassembly

The source of most compressor troubles can be traced not to one component alone, but to the relationship of one component with another. Too often, a compressor can be partially disassembled in search of the cause of a certain trouble and all evidence is destroyed during disassembly. Check again to be sure an easy solution to the problem has not been overlooked.

D. Find And Correct Basic Cause

After a mechanical failure has been corrected, be sure to locate and correct the cause of the trouble so the same failure will not be repeated. A complaint of "premature breakdown" may be corrected by repairing any improper wiring connections, but something caused the defective wiring. The cause may be excessive vibration.

TROUBLESHOOTING CHART

Bold Headings depict the COMPLAINT - Subheadings depict the CAUSE

Note: Subheadings suggest order to follow in cause of troubleshooting.

Short Air Cleaner Life:

Dirty Operating Conditions
Inadequate Element Cleaning
Defective Service Indicator
Incorrect Stopping Procedure
Wrong Air Filter Element

Excessive Oil In Air:

High Oil Level
Out of Level > 15 degrees
Clogged Scavenge Orifice
Scavenge Tube Blocked
Defective Scavenge Check Valve
Sep. Tank Blown Down Too Quickly
Defective Minimum Pressure Valve

Will Not Unload:

Leaks in Regulator Piping
Incorrect Pressure Regulator Adjustment
Malfunctioning Pressure Regulator
Malfunctioning Inlet Unloader/Butterfly Valve
Ice in Regulation Lines/Orifice

Oil In Air Cleaner:

Incorrect Stopping Procedure

Safety Valve Relieves:

Leaks in Regulator Piping
Incorrect Pressure Regulator Adjustment
Malfunctioning Pressure Regulator
Malfunctioning Inlet Unloader/Butterfly Valve
Defective Separator Element
Ice in Regulation Lines/Orifice

Excessive Compressor Oil Temperature:

Ambient Temperature Too High
Out of Level > 15 degrees
Low Oil Level
Dirty Cooler
Dirty Operating Conditions
Operating Pressure Too High
Malfunctioning Thermostat
Defective Minimum Pressure Valve
Blocked or Restricted Oil Lines
Airend Malfunctioning
Compressor Oil Cooler Fan Running Too Slowly

Excessive Vibration:

Out of Balance Fan
Airend Malfunctioning
Damaged Motor to Airend Coupling

Low CFM:

Low Motor RPM
Dirty Air Filter
Incorrect Pressure Regulator Adjustment
Malfunctioning Inlet Unloader/Butterfly Valve
Defective Minimum Pressure Valve
Defective Separator Element

Unit Shutdown:

Compressor Oil Temp. Too High
Loose Wire Connection
Defective Discharge Air Temp. Switch
Airend Malfunctioning
Compressor Drive Motor Malfunctioning
Compressor Oil Cooler Fan Not Running or Running Too Slowly

Won't Start/Run

Malfunctioning Start Switch
Compressor Oil Temp. Too High
Compressor Drive Motor Malfunctioning
Airend Malfunctioning

SECTION 7 – GENERAL DATA

Compressor Model	XHP900CM
Rated Delivery - CFM (litres/sec.).....	900 (425)
Rated Pressure - PSI (kPa).....	350 (2413)
Compressor Lube Capacity (Refill) – U.S. gal. (litres).....	44 (167)
Compressor Oil Filter Element	36860336
Compressor Oil Separator Element.....	36762250
Air Cleaner Element (Primary).....	35384619
Air Cleaner Element (Safety).....	35384627
Overall Length (Compressor Module) – inch (mm).....	63.6 (1615)
Overall Height (Compressor Module) – inch (mm).....	55.5 (1410)
Overall Width (Compressor Module) – inch (mm).....	51.5 (1308)
Overall Length (Air Receiver Module) – inch (mm).....	37.0 (940)
Overall Height (Air Receiver Module) – inch (mm).....	60.8 (1544)
Overall Width (Air Receiver Module) – inch (mm).....	27.0 (686)
Weight (Compressor Module) – pounds (kilograms).....	3100 (1406)
Weight (Air Receiver Module) – pounds (kilograms).....	815 (370)
Weight (System with lubricants) – pounds (kilograms).....	4320 (1960)
Input Power Requirements/Interface:	
• Horsepower (MIN.).....	395
• Speed (R.P.M.)	1800
Mounting Interface:	
• 18-10 Spicer Flange	

Built by INGERSOLL-RAND Company, Mocksville, N.C. 27028 USA

SECTION 8 - MAINTENANCE

CAUTION

Any unauthorized modification or failure to maintain this equipment may make it unsafe and out of factory warranty.

WARNING

If performing more than visual inspections, disconnect driver engine battery cables and open manual blow-down valve.

Use extreme care to avoid contacting hot surfaces (heat exchange and piping, air receiver and air discharge piping, etc.).

Never operate this machine with any guards removed.

Inch and metric hardware was used in the design and assembly of this unit. Consult the parts manual for clarification of usage.

GENERAL

In addition to periodic inspections, many of the components in this unit require periodic servicing to provide maximum output and performance. Servicing may consist of pre-operation and post-operation procedures to be performed by the operating or maintenance personnel. The primary function of preventive maintenance is to prevent failure, and consequently, the need for repair. Preventive maintenance is the easiest and the least expensive type of maintenance. Maintaining your unit and keeping it clean at all times will facilitate servicing.

SCHEDULED MAINTENANCE

The maintenance schedule is based on normal operation of the unit. In the event unusual environmental operating conditions exist, the schedule should be adjusted accordingly.

COMPRESSOR OIL LEVEL

The oil level should be checked before the unit is operated. The optimum operating level is midway of the sight tube on the side of the receiver tank. See the decal beside the sight tube. If the oil level is not in the "OK" range, make appropriate corrections (Add or Drain). A totally filled sight tube in which the level is not visible indicates an over-full condition and requires that oil be drained.

AIR CLEANER

This unit is equipped with AIR FILTER RESTRICTION INDICATOR on the front panel, serving both compressor inlet air cleaners.

This should be checked daily during operation. If the indicator shows (red) with the unit operating at full speed, servicing of the cleaner element is necessary.

Also weekly, squeeze the rubber valve (pre-cleaner dirt dump) on each air cleaner housing to ensure that they are not clogged.

If flagged, the air filter restriction indicator must be reset after unit is shut down and the air cleaners are serviced. Reset by pushing button on top of indicator.

To service the air cleaners on all units proceed as follows:

1. Loosen outer wing nut and remove cover. Remove element.
2. Inspect air cleaner housing for any condition that might cause a leak and correct as necessary.
3. Wipe inside of air cleaner housing with a clean, damp cloth to remove any dirt accumulation, especially in the area where the element seals against the housing.
4. Inspect element by placing a bright light inside and rotating slowly. If any holes or tears are found in the paper, discard this element. If no ruptures are found, the element can be cleaned.
5. If a new air filter element is to be used check it closely for shipping damage.

-
6. Install cleaned or new elements in the reverse order to the above. Tighten wing nuts firmly and replace cotter pin.
 7. Inspect to ensure that the end cap seals tightly 360 degrees around the air cleaner body.

In the event that the filter element must be reused immediately, compressed air cleaning (as follows) is recommended since the element must be thoroughly dry. Direct compressed air through the element in the direction opposite to the normal airflow through the element.

Move the nozzle up and down while rotating the element. Be sure to keep the nozzle at least one inch (25.4mm) from the pleated paper.

NOTE: To prevent damage to the element, never exceed a maximum air pressure of 100 psi (700 kPa).

In the event the element is contaminated with dry dirt, oil or greasy dirt deposits, and a new element is not available, cleaning can be accomplished by washing, using the air cleaner element manufacturer's recommendations.

NOTE: It is recommended that replacement elements be installed in the unit. The elements just removed for cleaning can be washed and stored as future replacement elements.

In addition, the air cleaner system (housing and piping) should be inspected every month for any leakage paths or inlet obstructions. Make sure the air cleaner mounting bolts and clamps are tight. Check the air cleaner housing for dents or damage which could lead to a leak. Inspect the air transfer tubing from the air cleaner to the compressor and the engine for leaks.

Make sure that all clamps and flange joints are tight.

GAUGES

The instruments or gauges are essential for safety, maximum productivity and long service life of the machine. Inspect the gauges prior to start-up. During operation observe the gauges for proper functioning. Refer to Operating Instructions, for the normal readings.

COMPRESSOR OIL COOLER

The compressor lubricating and cooling oil is cooled by means of a fin and tube-type oil cooler. The lubricating and cooling oil, flowing internally through the core section, is cooled by the air stream from the cooling fan flowing past the core section. When grease, oil and dirt accumulate on the exterior surfaces of the oil cooler, its efficiency is impaired.

Each month it is recommended that the oil coolers be cleaned by directing compressed air which contains a nonflammable safety solvent through the core of the oil cooler. This should remove the accumulation of grease, oil and dirt from the exterior surfaces of the oil cooler cores so that the entire cooling area can transmit the heat of the lubricating and cooling oil to the air stream.

In the event foreign deposits, such as sludge and lacquer, accumulate in the oil coolers to the extent that cooling efficiency is impaired, a resulting high discharge air temperature is likely to occur, causing shut down of the unit.

To correct this situation it will be necessary to clean the coolers using a cleaning compound in accordance with the manufacturer's recommendations.

HOSES

Each month it is recommended that all of the intake lines to and from the air cleaners and flexible hoses used for air and oil be inspected.

To ensure freedom from air leaks, all rubber hose joints and the screw-type hose clamps must be absolutely tight. Regular inspection of these connections for wear or deterioration is necessary.

Premature wear of the compressor is ASSURED whenever dust-laden air is permitted to enter the compressor intake.

The flexible hoses used in the oil and air lines on these units are primarily used for their ability to accommodate relative movement between components. It is important they be periodically inspected for wear and deterioration. It is also important the operator does not use the hoses as convenient hand holds or steps. Such use can cause early cover wear and hose failure.

NOTICE

Piping systems operating at less than 150 psi (1050 kPa) may use a special nylon tubing. The associated fittings are also of a special “push-in” design. If so, features are as follows:

Pulling on the tubing will cause the inner sleeve to withdraw and compress, thus tightening the connection. The tubing can be withdrawn only while holding the sleeve against the fitting. The tubing can be removed and replaced numerous times without losing its sealing ability.

To install the nylon tubing, make a mark (with tape or grease pencil) approximately 7/8 inch from the end of the tubing. Insert the tubing into the sleeve and “push-in” past the first resistance to the button. The mark should be approximately 1/16 inch from the sleeve, for the 3/8 inch O.D. tubing; 1/8 inch for the 0.25 inch O.D. tubing. This will ensure that the tubing is fully engaged in the sealing mechanism.

NOTICE

The oil filters must be replaced every 500 hours of operation or three (3) months, whichever comes first. On new or overhauled units, replace the element after the first 50 and 150 hours of operation; thereafter, service the oil filters every 500 hours.

To service the oil filters it will first be necessary to shut the unit down. Wipe off any external dirt and oil from the exterior of the filter to minimize any contamination from entering the lubrication system. Proceed as follows:

High pressure air can cause severe injury or death

WARNING

from hot oil and flying parts. Always relieve pressure before removing caps, plugs, covers or other parts from pressurized air system.

1. Open the service air valve(s) to ensure that system is relieved of all pressure. Close the valve(s).
2. Turn the spin-on filter element counterclockwise to remove it from the filter housing. Insert the filter.

NOTICE

If there is any indication of formation of varnishes, shellacs or lacquers on the oil filter element, it is a warning the compressor lubricating oil has improper characteristics and should be immediately changed.

3. Inspect the oil filter head to be sure the gasket was removed with the oil filter element. Clean the gasket seal area on the oil filter head.

NOTICE

Installing a new oil filter element when the old gasket remains on the filter head will cause an oil leak and can cause property damage.

4. Lubricate the new filter gasket with the same oil being used in the machine.
5. Install new filter by turning element clockwise until gasket makes initial contact. Tighten an additional ½ to ¾ turn.
6. Start unit and allow to build up to rated pressure. Check for leaks before placing unit back into service.

FASTENERS

Visually check entire unit in regard to bolts, nuts and screws being properly secured. Spot check several capscrews and nuts for proper torque. If any are found loose, a more thorough inspection must be made. Take corrective action.

COMPRESSOR OIL

The lubricating and cooling oil must be replaced every 1000 hours of operation or six (6) months, whichever comes first.

RECEIVER SEPARATOR SYSTEMS

WARNING

High pressure air can cause severe injury or death from hot oil and flying parts. Always relieve pressure before removing caps, plugs, covers or other parts from pressurized air system.

- **Open service valve.**
- **Ensure pressure is relieved, with BOTH:**
 - **Discharge air pressure gauge reads zero (0).**
 - **No air discharging from service valve.**

When draining oil, open valve at bottom of separator tank.

When adding oil, remove and replace (make tight) plug on side of separator tank.

In the compressor lubricating and cooling system, separation of the oil from the compressed air takes place in the receiver separator tank. As the compressed air enters the tank, the change in velocity and direction drop out most of the oil from the air.

Additional separation takes place in the oil separator element, which is located in the top of the tank.

Any oil accumulation in this separator element is continuously drained off by means of a scavenge tube which returns the accumulated oil to the system.

The life of the oil separator element is dependent upon the operating environment (soot, dust, etc.) and should be replaced every twelve months or 2000 hours. To replace the element proceed as follows:

- Ensure the tank pressure is zero.
- Disconnect the hose from the scavenge tube.
- Remove scavenge tube from tank cover.
- Disconnect service line from cover.
- Remove cover mounting screws.
- Remove cover and element.
- Remove any gasket material left on cover or tank.
- Install new element.

- Place a straightedge across top of element and measure from bottom of straightedge to bottom of element. (See drawing below)
- Replace scavenge tube in cover (cover is still off of tank).
- Measure from bottom of cover to end of scavenge tube. Measurement should be from 1/8" to 1/4" less than the element measurement. If not, cut to size.
- Remove scavenge tube.
- Reposition cover (use care not to damage gaskets).
- Replace cover mounting screws: tighten in a crisscross pattern.
- Reconnect service line. Replace scavenge tube. Reconnect hose.
- Close service valve. Start unit and look for leaks.

NOTICE

Do not remove staples from the element/gasket connection.

When replacing the element, the scavenge lines, orifice, filter and check valve should be thoroughly cleaned and the oil changed.

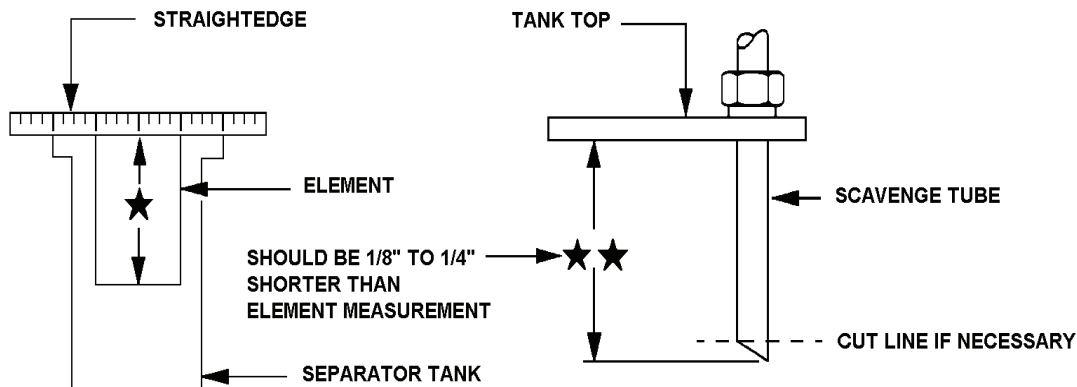

SCAVENGE LINE

WARNING

High pressure air can cause severe injury or death from hot oil and flying parts. Always relieve pressure before removing caps, plugs, covers or other parts from pressurized air system.

The scavenge line originates at the receiver separator tank cover and terminates at the compressor aircend through an orifice. Once a year or every 2000 hours of operation, whichever comes first, remove this line and the orifice, thoroughly clean, then reassemble.

Excessive oil carry-over may be caused by an oil-logged separator element. Do not replace element without first performing the following maintenance procedure:

1. **Check the oil level. Maintain as indicated earlier in this section.**
2. **Thoroughly clean scavenge line, any orifice and check valve.**
3. **Assure minimum pressure valve (if so equipped) has proper setting.**
4. **Run unit at rated operating pressure for 30 to 40 minutes to permit element to clear itself.**

EXTERIOR FINISH CARE

The unit was painted and heat cured at the factory with a high quality, thermostat polyester powder coating. The following care will ensure the longest possible life from this finish.

1. **If necessary to remove dust, pollen, etc. from housing, wash with water and soap or dish washing liquid detergent. Do not scrub with a rough cloth, pad, etc.**

2. **If grease removal is needed, a fast evaporating alcohol or chlorinated solvent can be used. Note: This may cause some dulling of the paint finish.**
3. **If the paint has faded or chalked, the use of a commercial grade, non-abrasive car wax may partially restore the color and gloss.**

Field Repair of Texture Paint

1. The sheet metal should be washed and clean of foreign material and then thoroughly dried.
2. Clean and remove all grease and wax from the area to be painted using Duponts 3900S Cleaner prior to sanding.
3. Use 320 grit sanding paper to repair any scratches or defects necessary.
4. Scuff sand the entire area to be painted with a red scotch brite pad.
5. Wipe the area clean using Duponts 3900S.
6. Blow and tack the area to be painted.
7. Apply a smooth coat of Dupont 1854S Tuffcoat Primer to all bare metal areas and allow to dry.
8. Apply 2 medium, wet coats of Dupont 222S Adhesion Promoter over the entire area to be painted, with a 5 minute flash in between coats.
9. To apply the texture coat, use Dupont 1854S Tuffcoat Primer. The proper technique to do this is to spray the Tuffcoat Primer using a pressure pot and use about 2-5 pounds of air pressure. This will allow the primer to splatter causing the textured look. Allow the texture coat to flash for about 20 minutes or until dry to touch.
10. Apply any of Dupont's Topcoat Finishes such as Imron™ or Centari™ according to the label instructions.

NOTE: To re-topcoat the texture surfaces when sheet metal repairs are not necessary, follow steps 1,2,4,5,6,8 and 10.

PREVENTIVE MAINTENANCE SCHEDULE

If operating in extreme environments (very hot, cold, dusty or wet), these time periods should be reduced.

	Daily	Weekly	Monthly	500 hrs /3 mos.	1000 hrs /6 mos.	2000 hrs /12 mos.
Compressor Oil Level	C					
Gauges/Lamps	C					
*Air Cleaner Service Indicators	C					
Air Cleaner Precleaner Dumps		C				
Hoses (Oil, Air, Intake Hydraulic)			C			
Automatic Shutdown System Test			C			
Air Cleaner System Visual			C			
Compressor Oil Cooler Exterior			C	Clean		
Fasteners				C		
Air Cleaner Elements				WI		
Compressor Oil Filter Element				R		
Compressor Oil					R	
Shutdown Switch Settings Test						C
Scavenger Orifice & Related Parts						Clean
Oil Separator Element						R

* Disregard if not appropriate for this particular machine

R = Replace C = Check (adjust or replace if necessary) Unit _____ Date _____
 L = Lubricate WI = Or when indicated Hours _____ Serviceman _____

LUBRICATION

Both compressor lubrication and cooling are accomplished by the compressor lubricating oil. The oil is forced from the oil storage reservoir, under system pressure, through an oil cooler and an oil filter directly to the compressor. When the compressor is operating at low capacity, some of the oil may bypass the cooler through a thermostatically controlled bypass valve. This valve bypasses varying amounts of oil, depending upon the temperature, until the oil being circulated reaches a temperature of 185°F (85°C) thus maintaining a higher average oil temperature thereby reducing the possibility of water vapor condensation in the oil.

Typical Lubricating and Cooling Oil System

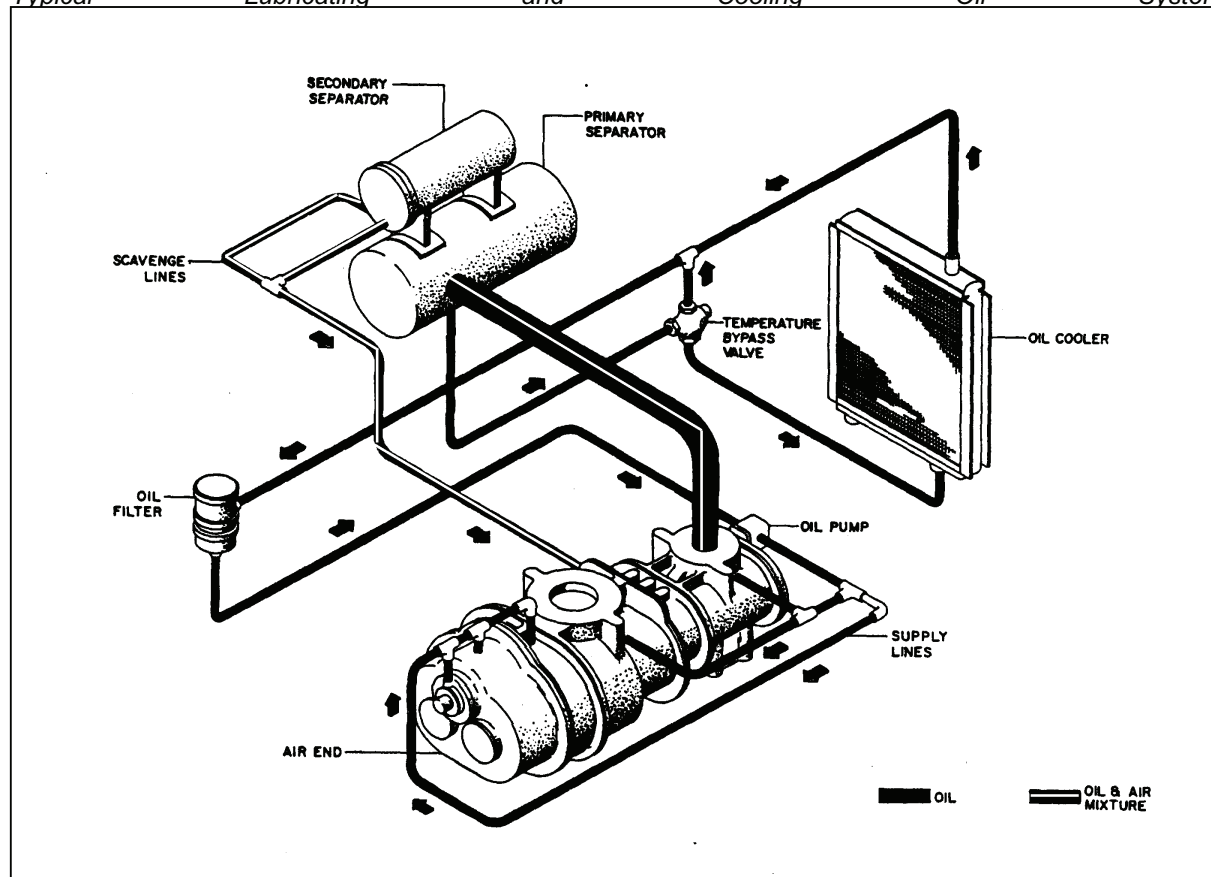

Relatively cool lubricating oil is admitted under pressure to the compressor bearings and is also injected in metered amounts, directly to the rotor chamber. All of the oil thus introduced mixes with, and passes on with the air being compressed, thus removing the heat of compression to a large degree. On its way to the final discharge connection, the air passes through a receiver/separator. A scavenger line returns any remaining separated oil back to the inlet of the compressor.

Fill the oil storage reservoir in the receiver/separator with new oil before operating the unit. Recharge the compressor by first removing the air filter and pouring about two gallons (7.57 liters) of oil into the compressor inlet.

NOTE

Recharging of the compressor with oil is absolutely necessary on units that have been placed in extended storage (6 months or more).

FLUIDS AND LUBRICANTS TABLE

Design Operating Pressure	Ambient Temperature	Specification
100 psi to 300 psi	-10°F to 125°F (-23°C to 52°C)	IR Pro •Tec™ Mil PRF 2104G SAE 10W
100 psi to 300 psi	-40°F to 125°F (-40°C to 52°C)	IR Performance 500 Mil PRF 46167
350 psi	65°F to 125°F (18°C to 52°C) -10°F to 125°F (-23°C to 52°C) -40°F to 65°F (-40°C to 18°C)	IR XHP 1001 IR XHP 505 IR Performance 500 Mil PRF 46167
500 psi	50°F to 125°F (10°C to 52°C) 10°F to 65°F (-12°C to 18°C) below 10°F (-12°C)	IR XHP 1001 IR XHP 505 Consult Factory

If the unit has been operated for 1,000 hours, it should be completely drained of oil. If the unit has been operated under adverse conditions or under long shutdown periods, an earlier change may be necessary as oil deteriorates with time as well as by operating conditions. Complete replacement of the old oil with clean oil every 500 to 1,000 hours, depending upon operating conditions, not only is desirable, but is good insurance against the accumulation of dirt, sludge or oxidized oil products.

Completely drain the receiver/separator and the piping. If the oil is drained immediately after the unit has been run for some time, most of the sediment will be in suspension and will drain more readily.

CAUTION

Shorter oil change intervals may be necessary if unit is operated under adverse conditions.

WARNING

Do not, under any circumstances, open any drain cocks, remove any plugs or the oil filler plug from the compressor lubricating and cooling oil system without making sure the air receiver system had been completely relieved of all air pressure.

CAUTION

Some oil mixtures are incompatible with each other and result in the formation of varnishes, shellacs or lacquers, which may be insoluble. Such deposits can cause serious trouble including clogging of the filter. Where possible, try to avoid mixing oils of the same type but different brands. A brand change is best made at the time of a complete oil change. Refer to the **Fluids & Lubrication Table** for oil recommendation.

SECTION 9 - PARTS ORDERING

GENERAL

This publication, which contains an illustrated parts breakdown, has been prepared as an aid in locating those parts which may be required in the maintenance of the unit. All of the compressor parts, listed in the parts breakdown, are manufactured with the same precision as the original equipment. For the greatest protection always insist on genuine Ingersoll-Rand Company parts for your compressor.

The unit covered by the manual has been custom designed and built to satisfy our customer's unique specifications by the Portable Compressor Division (PCD) Customer 1 Process Team.

Some of the unique, special order components may not be included in the illustrated parts breakdown. Supplemental pages with photo illustrations have been added to assist in identifying special order parts when required for service orders.

Contact the PCD Parts Department for assistance when ordering these special parts. Include the unit serial number with all orders.

NOTICE

Ingersoll-Rand Company can bear no responsibility for injury or damages resulting directly from the use of non-approved repair parts.

Ingersoll-Rand Company service facilities and parts are available worldwide. There are Ingersoll-Rand Company Construction Equipment Group Sales Offices and authorized distributors located in the principal cities of the United States. In Canada our customers are serviced by the Canadian Ingersoll-Rand Company, Limited. There are also Ingersoll-Rand International autonomous companies and authorized distributors located in the principal cities throughout the free world.

Special order parts may not be included in this manual. Contact the Mocksville Parts Department with the unit serial number for assistance with these special parts.

DESCRIPTION

The illustrated parts breakdown illustrates and lists the various assemblies, subassemblies and detailed parts which make up this particular machine. This covers the standard models and the more popular options that are available.

A series of illustrations show each part distinctly and in location relative to the other parts in the assembly. The part number, the description of the part and the quantity of parts required are shown on each illustration or on adjacent page.

The quantities specified are the number of parts used per one assembly and are not necessarily the total number of parts used in the machine. Where no quantity is specified the quantity is assumed to be one.

Each description of a part is based upon the "noun first" method, i.e., the identifying noun or item name is always the first part of the description. The noun name is generally followed by a single descriptive modifier. The descriptive modifier may be followed by words or abbreviations such as upper, lower, inner, outer, front, rear, RH, LH, etc. when they are essential.

In referring to the rear, the front or to either side of the unit, always consider the **drive end** of the unit as the **front**. Standing at the rear of the unit facing the drive end (front) will determine the right and left sides.

FASTENERS

Both SAE/inch and ISO/metric hardware have been used in the design and assembly of these units. In the disassembly and reassembly of parts, extreme care must be taken to avoid damaging threads by the use of wrong fasteners. In order to clarify the proper usage and for exact replacement parts, all standard fasteners have been identified by part number, size and description. This will enable a customer to obtain fasteners locally rather than ordering from the factory. These parts are identified in tables that will be found at the rear of the parts illustrations. Any fastener that has not been identified by both part number and size is a specially engineered part that must be ordered by part number to obtain the exact replacement part.

MARKINGS AND DECALS

NOTICE

Do not paint over safety warnings or instructional decals. If safety warning decals become illegible, immediately order replacements from the factory.

Part numbers for original individual decals and their mounting locations are shown within Parts List. These are available as long as a particular model is in production.

Afterwards, service sets of exterior decals and current production safety warning decals are available. Contact the Product Support Group at Mocksville for your particular needs and availability.

HOW TO USE PARTS LIST

- a. Turn to Parts List Section.
- b. Locate the area or system of the compressor in which the desired part is used and find illustration page number.
- c. Locate the desired part on the illustration by visual identification and make note of part number and description.

HOW TO ORDER

The satisfactory ordering of parts by a purchaser is greatly dependent upon the proper use of all available information. By supplying your nearest sales office, autonomous company or authorized distributor, with complete information, you will enable them to fill your order correctly and to avoid any unnecessary delays.

In order that all avoidable errors may be eliminated, the following instructions are offered as a guide to the purchaser when ordering replacement parts:

- a. Always specify the model number of the unit as shown on the general data decal attached to the unit.
- b. Always specify the serial number of the unit. **THIS IS IMPORTANT.** The serial number of the unit will be found stamped on a plate attached to the unit.

- c. Always specify the number of the parts list publication.
- d. Always specify the quantity of parts required.
- e. Always specify the part number, as well as the description of the part, or parts, exactly as it is given on the parts list illustration.

In the event parts are being returned to your nearest sales office, autonomous company or authorized distributor, for inspection or repair, it is important to include the serial number of the unit from which the parts were removed.

TERMS/CONDITIONS ON PARTS ORDERS

Acceptance: Acceptance of an offer is expressly limited to the exact terms contained herein. If purchaser's order form is used for acceptance of an offer, it is expressly understood and agreed that the terms and conditions of such order form shall not apply unless expressly agreed to by Ingersoll-Rand Company ("Company") in writing. No additional or contrary terms will be binding upon the Company unless expressly agreed to in writing.

Taxes: Any tax or other governmental charge now or hereafter levied upon the production, sale, use or shipment of material and equipment ordered or sold is not included in the Company's price and will be charged to and paid for by the Purchaser.

Delivery: Shipping dates are approximate. The Company will use best efforts to ship by the dates specified; however, the Company shall not be liable for any delay or failure in the estimated delivery or shipment of material and equipment or for any damages suffered by reason thereof.

Shipping dates shall be extended for delays due to acts of God, acts of Purchaser, acts of Government, fires, floods, strikes, riot, war, embargo, transportation shortages, delay or default on the part of the Company's vendors, or any other cause beyond the Company's reasonable control.

Should Purchaser request special shipping instruction, such as exclusive use of shipping facilities, including air freight when common carrier has been quoted and before change order to purchase order can be received by the Company, the additional charges will be honored by the Purchaser.

Warranty: The Company warrants that parts manufactured by it will be as specified and will be free from defects in materials and workmanship. The Company's liability under this warranty shall be limited to the repair or replacement of any part which was defective at the time of shipment provided Purchaser notifies the Company of any such defect promptly upon discovery, but in no event later than three (3) months from the date of shipment of such part by the Company. The only exception to the previous statement is the extended warranty as it applies to the special airend exchange program.

Repairs and replacements shall be made by the Company F.O.B. point of shipment. The Company shall not be responsible for costs of transportation, removal or installation.

Warranties applicable to material and equipment supplied by the Company but wholly manufactured by others shall be limited to the warranties extended to the Company by the manufacturer which are able to be conveyed to the Purchaser.

The company makes no other warranty or representation of any kind whatsoever, expressed or implied, except that of title, and all implied warranties, including any warranty of merchantability and fitness for a particular purpose, and hereby disclaimed.

Limitation of Liability:

The remedies of the Purchaser set forth herein are exclusive, and the total liability of the Company with respect to this order whether based on contract, warranty, negligence, indemnity, strict liability or otherwise, shall not exceed the purchase price of the part upon which such liability is based.

The Company shall in no event be liable to the Purchaser, any successors in interest or any beneficiary of this order for any consequential, incidental, indirect, special or punitive damages arising out of this order or any breach thereof, or any defect in, or failure of, or malfunction of the parts hereunder, whether based upon loss of use, lost profits or revenue, interest, lost goodwill, work stoppage, impairment of other goods, loss

by reason of shutdown or non-operation, increased expenses of operation or claims of customers of Purchaser for service interruption whether or not such loss or damage is based on contract, warranty, negligence, indemnity, strict liability or otherwise.

AIREND EXCHANGE PROGRAM

Your Ingersoll-Rand Company Construction Equipment Group Sales Offices and authorized distributors as well as Ingersoll-Rand International autonomous companies and authorized distributors now have an airend exchange program to benefit portable compressor users.

On the airend exchange program the exchange price is determined by the age and condition of the airend and may be classified by one of the following categories.

Category "A": The airend must not be over two years old and must have reusable rotor housing(s) and rotor(s).

Category "B": The airend must be between two and five years old and returned with two or more reusable major castings.

Category "C": The airend must be over five years old.

Your nearest sales office, autonomous company or authorized distributor must first contact the Parts Service Department at the factory at which your portable air compressor was manufactured for an airend exchange number. The airend must be tagged with this preassigned number and returned to the factory prepaid. The airend must be intact, with no excluded parts, otherwise the exchange agreement may be canceled. The warranty on an exchange or factory rebuilt airend is 365 days.

NOTICE

Airends being returned to the factory in connection with a WARRANTY CLAIM must be processed through the Customer Service Department. If returned without a Warranty MRR (Material Return Request) Number, no warranty claim will be considered.

SECTION 10 – PARTS LIST

	<u>Page No</u>
1. Frame & Enclosure	41-43
2. Air End & Components	44-49
3. Cooling Fan	50-52
4. Oil Cooler	53
5. Shutter Assembly	54
6. Air Filters	55-56
7. Instrumentation	57
8. Separator Tank Assembly	58-60
9. Air & Oil Piping	61-66
10. Decals	67-71

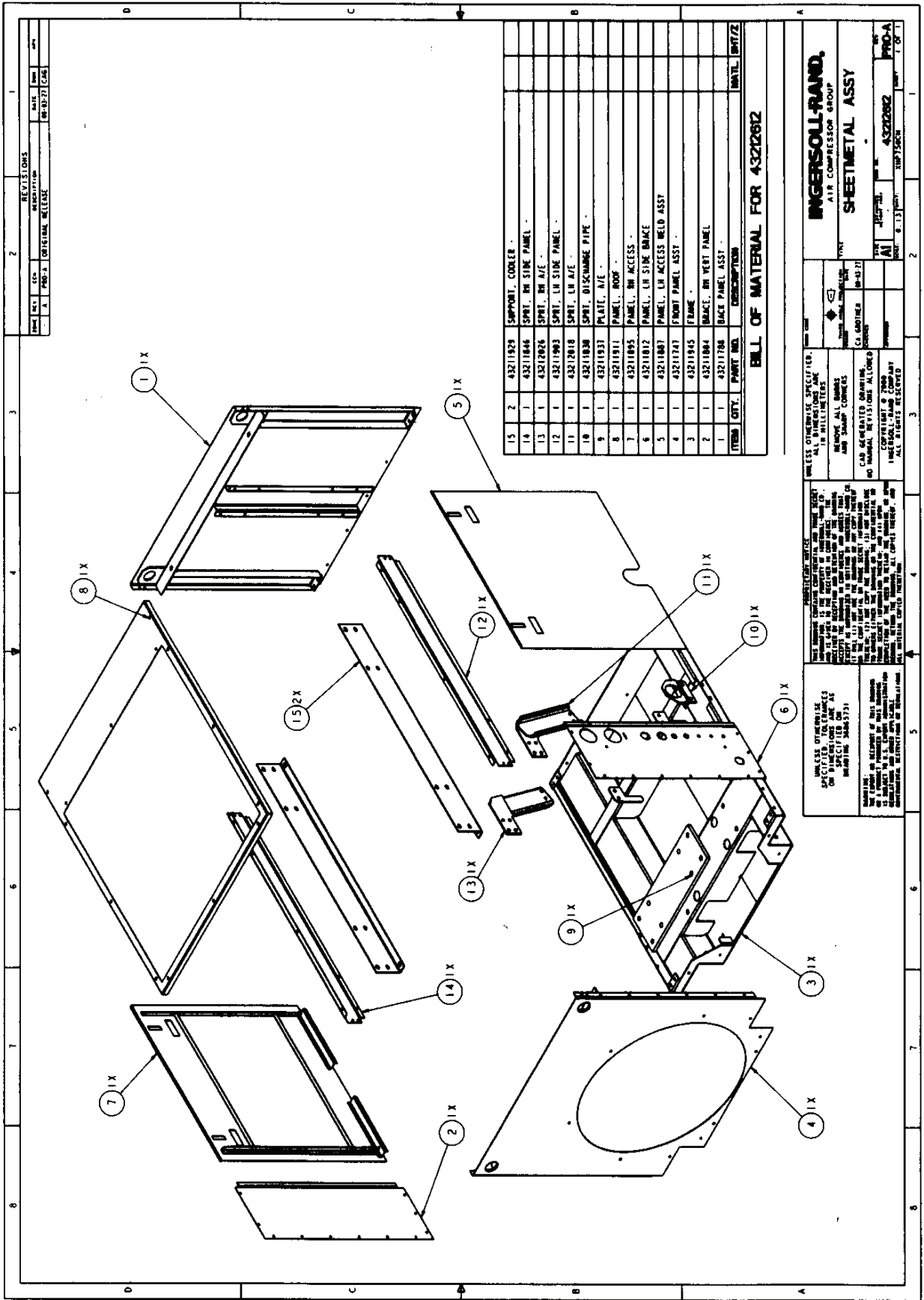

REV	BY	CHK	DATE	DESCRIPTION
1	PRO-1		09-03-72	ORIGINAL RELEASE

ITEM	QTY.	PART NO.	DESCRIPTION	MATL.	UNIT
15	2	43211929	SUPPORT COOLER		
14	1	43211846	SPRT. RH SIDE PANEL		
13	1	43212026	SPRT. LH A/E		
12	1	43211903	SPRT. LH SIDE PANEL		
11	1	43212018	SPRT. LH A/E		
10	1	43211830	SPRT. DISCHARGE PIPE		
9	1	43211931	PLATE, A/E		
8	1	43211911	PANEL, ROOF		
7	1	43211895	PANEL, RH ACCESS		
6	1	43211812	PANEL, LH SIDE BRACE		
5	1	43211887	PANEL, LH ACCESS WELD ASST		
4	1	43211747	FRONT PANEL ASST		
3	1	43211945	FRAME		
2	1	43211884	BRACE, RH VERT PANEL		
1	1	43211788	BACK PANEL ASST		

BILL OF MATERIAL FOR 43212612

INGERSOLL-RAND,
AIR COMPRESSOR GROUP

SHEETMETAL ASSY

DATE: 09-13-72
REV: 1
PART NO: 43212612
DRAWN: SUP75200

NO. OF SHEETS: 1 OF 1

UNLESS OTHERWISE SPECIFIED, ALL DIMENSIONS ARE IN MILLIMETERS AND DECIMALS THEREOF SHALL BE TO NEAREST 0.1 MILLIMETER. DIMENSIONS IN PARENTHESES ARE FOR INFORMATION ONLY.

ALL RIGHTS RESERVED

INGERSOLL-RAND COMPANY

ENCLOSURE

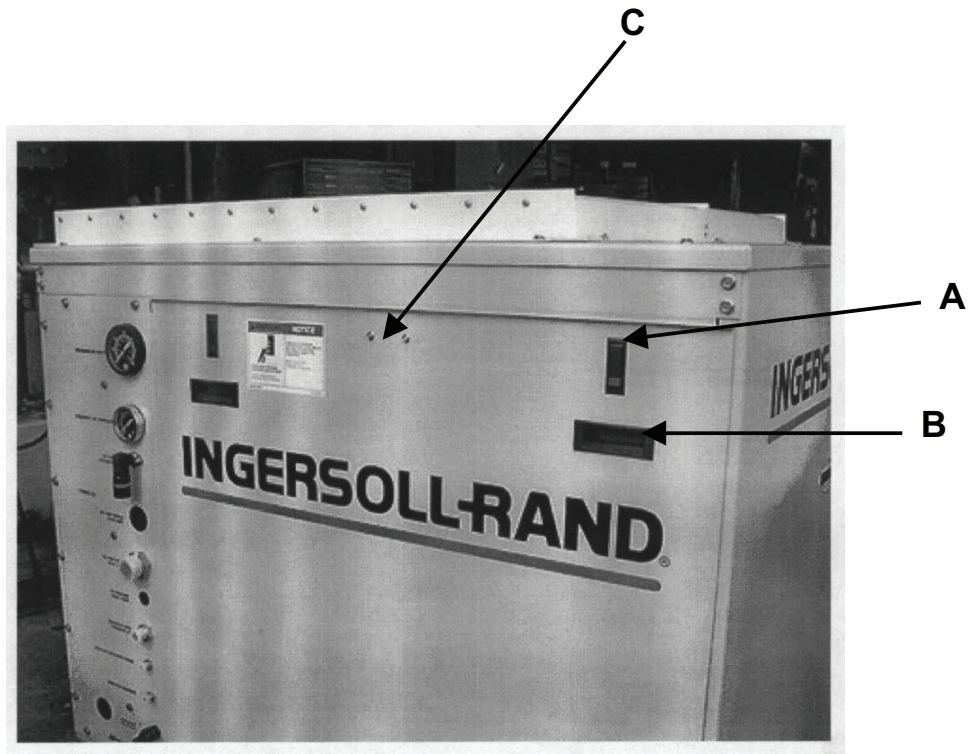

ITEM	PART NUMBER	DESCRIPTION
A	36892677	Latch (4)
B	43211820	Door Pull (4)
C	43213446	Door Catch Assembly (2) (See next page for detail)

ENCLOSURE

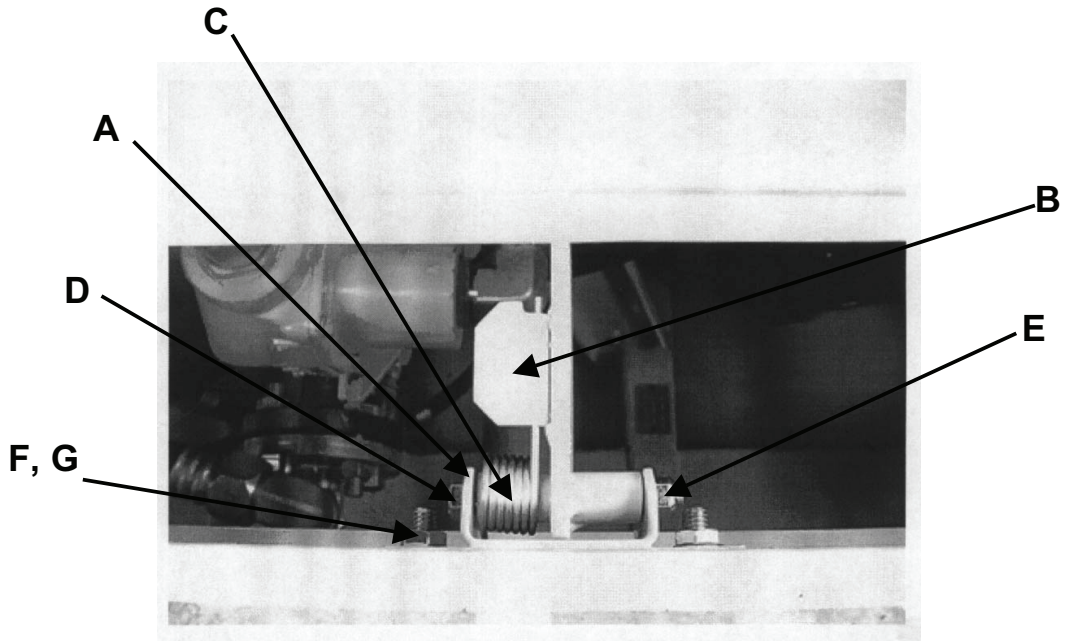

ITEM	PART NUMBER	DESCRIPTION
A	43213032	Bracket, Catch
B	43213024	Catch Arm
C	43213040	Spring
D	36785327	Screw, Pivot
E	36769032	Nut Lkg.
F	35144328	Screw (2/Catch Assy)
G	35144492	Nut (2/Catch Assy)

AIR END

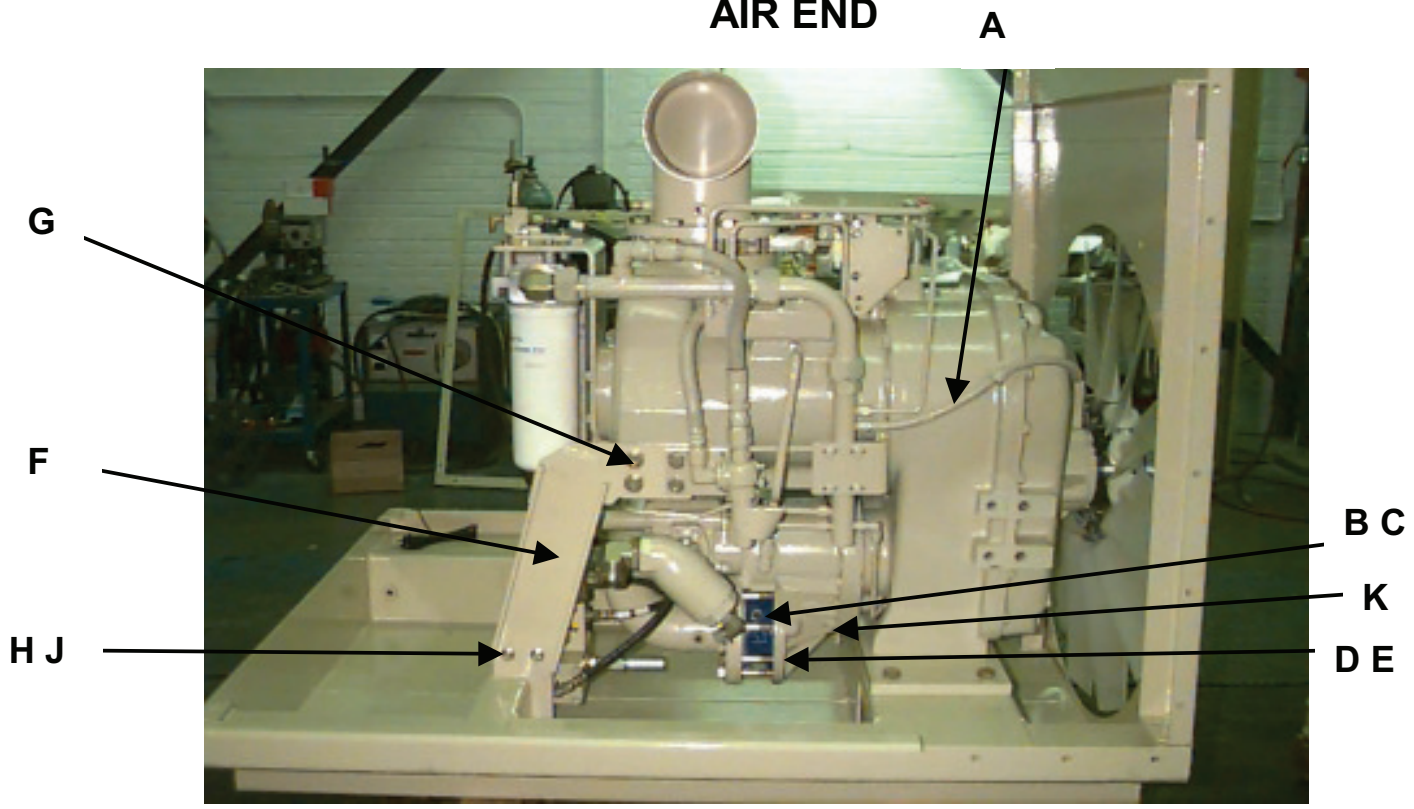

ITEM	PART NUMBER	DESCRIPTION
A	36063055	Compressor HR2 (see Dwg. 36735967 for parts breakdown)
B	36843720	Check Valve
C	95225116	Gasket (2)
D	35376094	Bolt (8)
E	11A5G8	Washer (8)
F	43212026	Support RH
	43212018	Support LH (Opposite Side)
G	35375591	Bolt (7)
H	35252568	Bolt (4)
J	35252618	Nut (4)
K	36790780	Switch, Disch. Temp.

AIR END

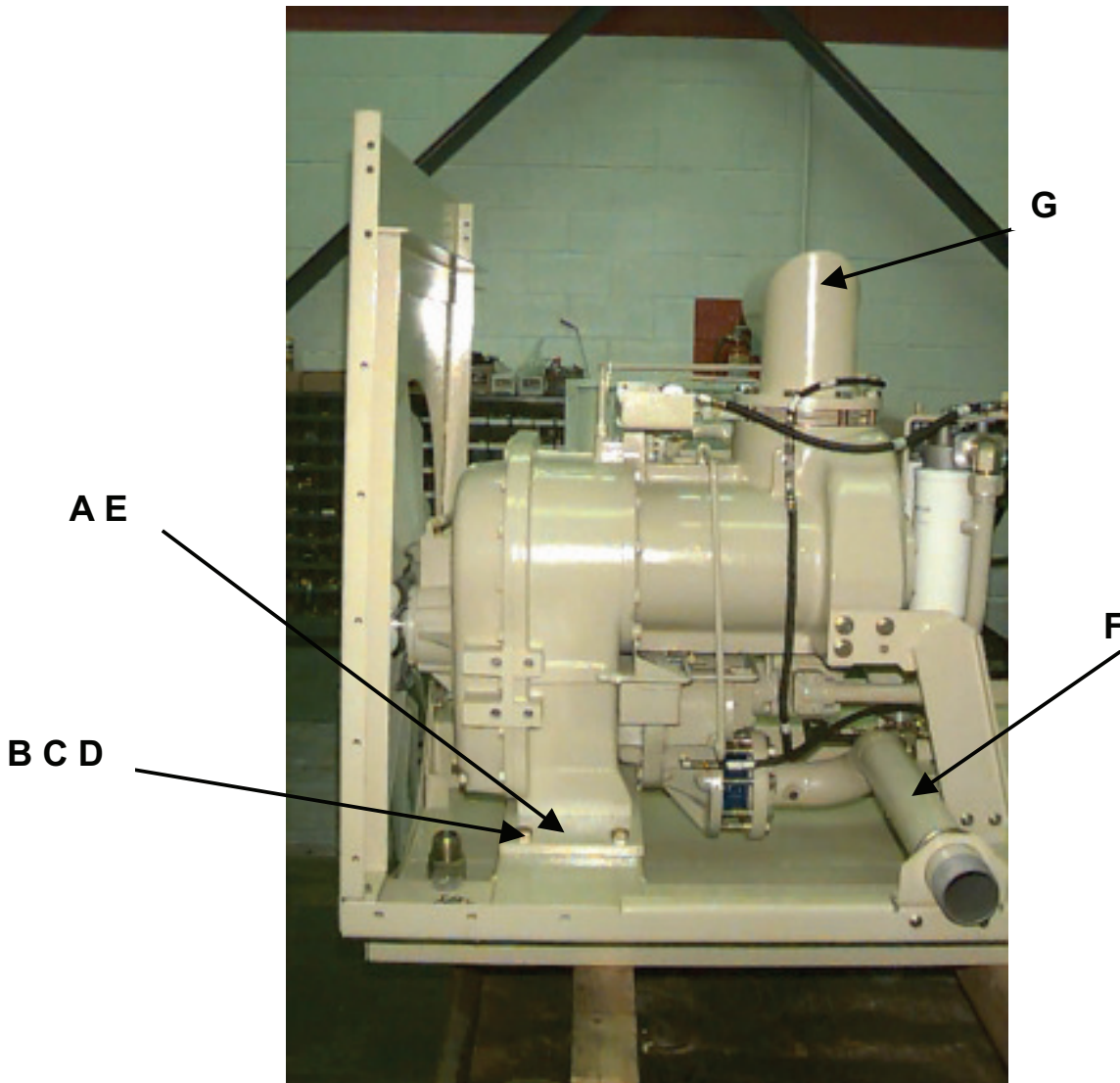

ITEM	PART NUMBER	DESCRIPTION
A	43211937	Plate A/E Support
B	95934386	Bolt (4)
C	95935011	Washer (4)
D	95922928	Nut (4)
E	35375377	Bolt (4)(Plate to A/E-not shown)
F	43212059	Discharge Pipe
G	43212042	Flange, Air Inlet

AIR END

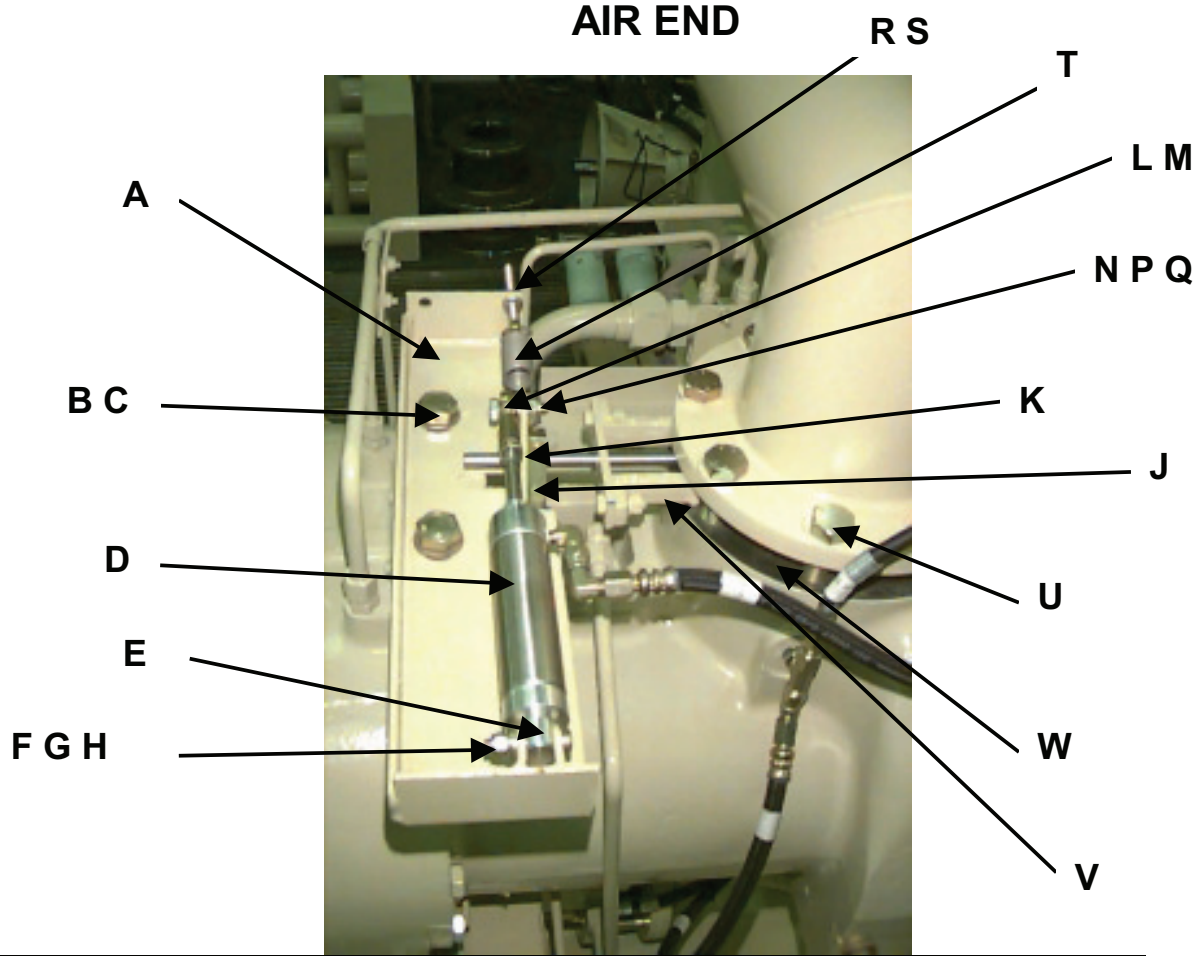

ITEM	PART NUMBER	DESCRIPTION
A	36898005	Bracket, Air Cylinder
B	35375856	Bolt (2)
C	95935011	Washer (2)
D	35584689	Air Cylinder
E	35288885	Bushing
F	35288893	Pivot Bolt
G	95934998	Washer
H	95923314	Nut
J	35264951	Control Lever
K	35607910	Lever
L	35300532	Rod End
M	95926028	Nut Jam
N	95934626	Bolt
P	95923330	Nut
Q	95934907	Washer
R	35605799	Adjusting Rod
S	35145077	Nut
T	35605799	Spring
U	35375963	Bolt (8)
V	36884112	Valve, Butterfly
W	36754059	Gasket (2)

Printed: RUNYANJM | UNCONTROLLED DOCUMENT | 09:31:39 AM 08-03-2000

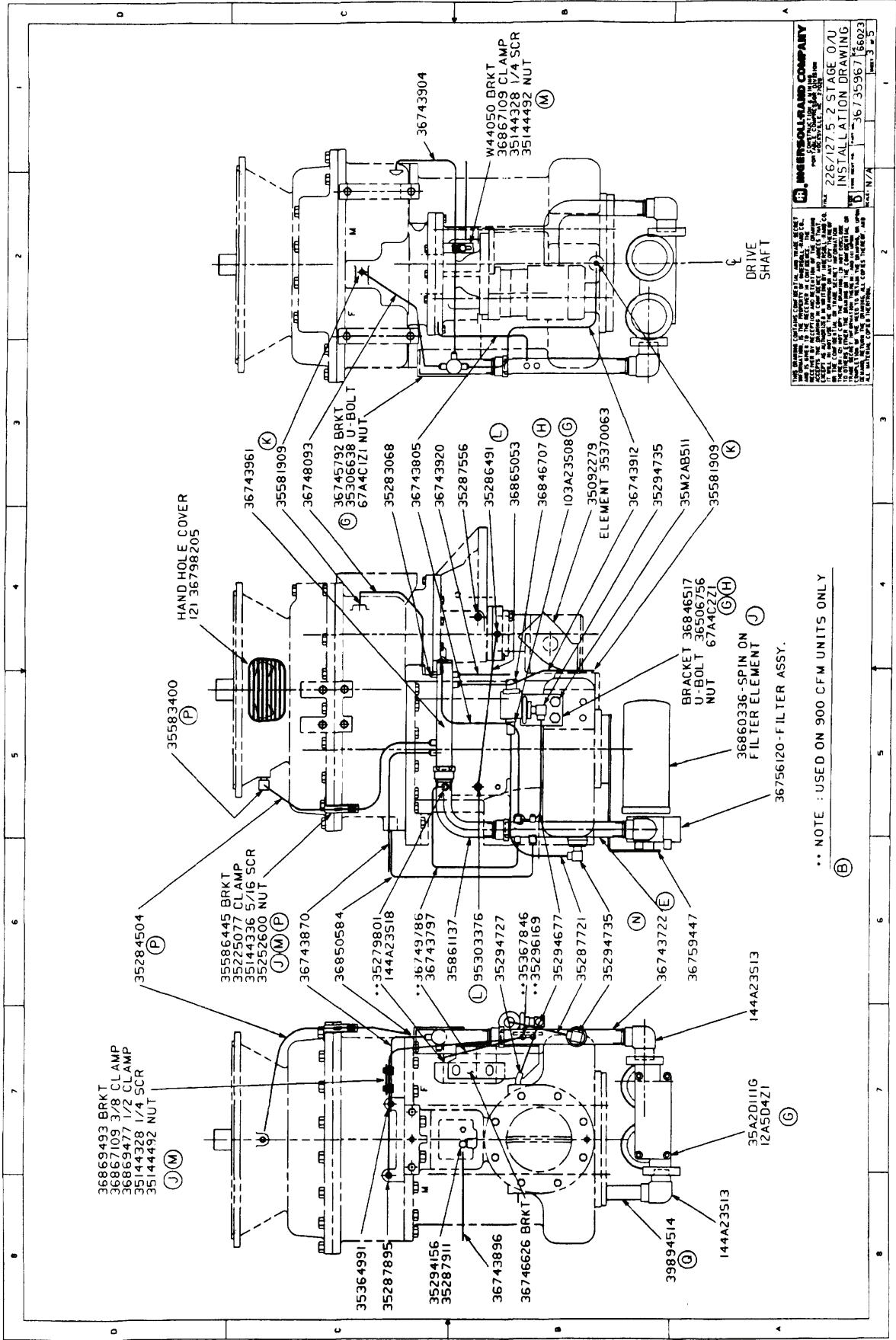

WESSLING COMPANY
 226/127.5-2 STAGE O/U
 INSTALLATION DRAWING
 36735967 (6023)
 SHEET 3 OF 5

** NOTE : USED ON 900 CFM UNITS ONLY

J:\367XXXXX\3673XXXXX\36735XXXX\36735967.tif

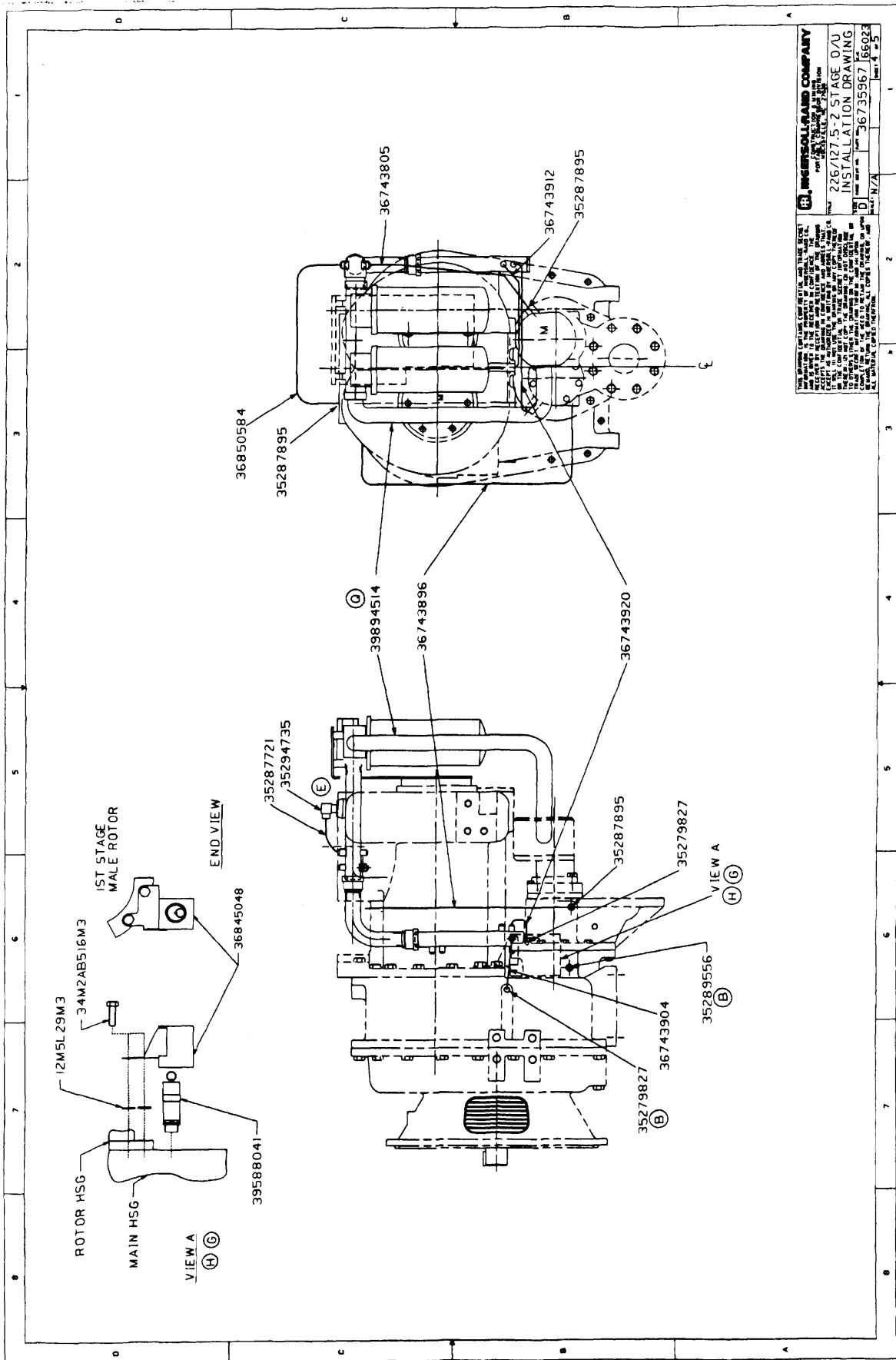

INGERSOLL RAND COMPANY
 226/127.5-2 STAGE O/U
 INSTALLATION DRAWING
 Part No. 36735967 Rev. 02
 Date 11/25/00
 Drawn by N/A
 Checked by N/A
 Approved by N/A

J:\367XXXXX\36735XXXXX\36735967.tif

Printed: RUNYANJM | UNCONTROLLED DOCUMENT | 09:31:39 AM 08-03-2000

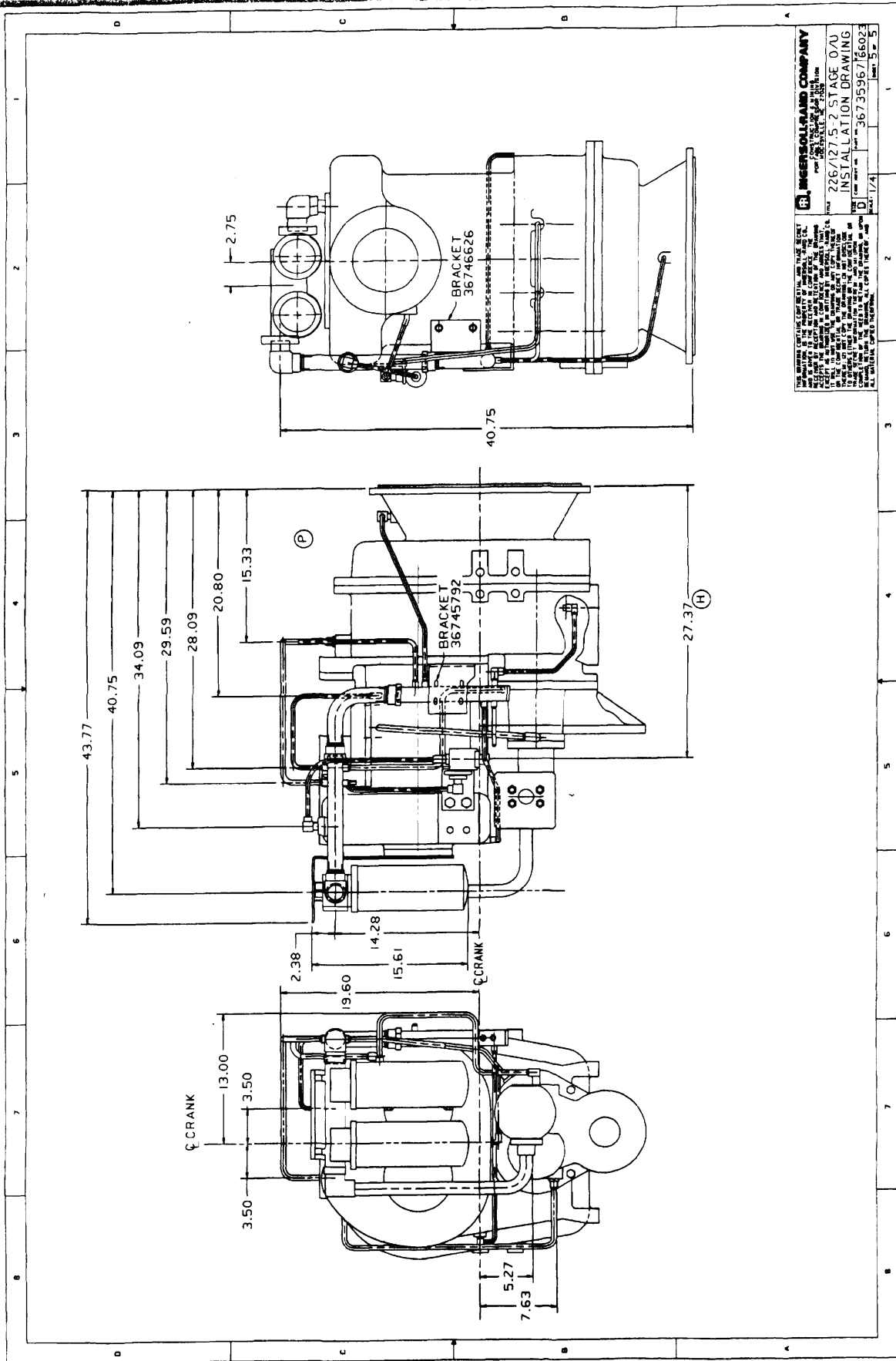

J:\367XXXXXX\3673XXXX\36735967\36735967.dwg

COOLING FAN

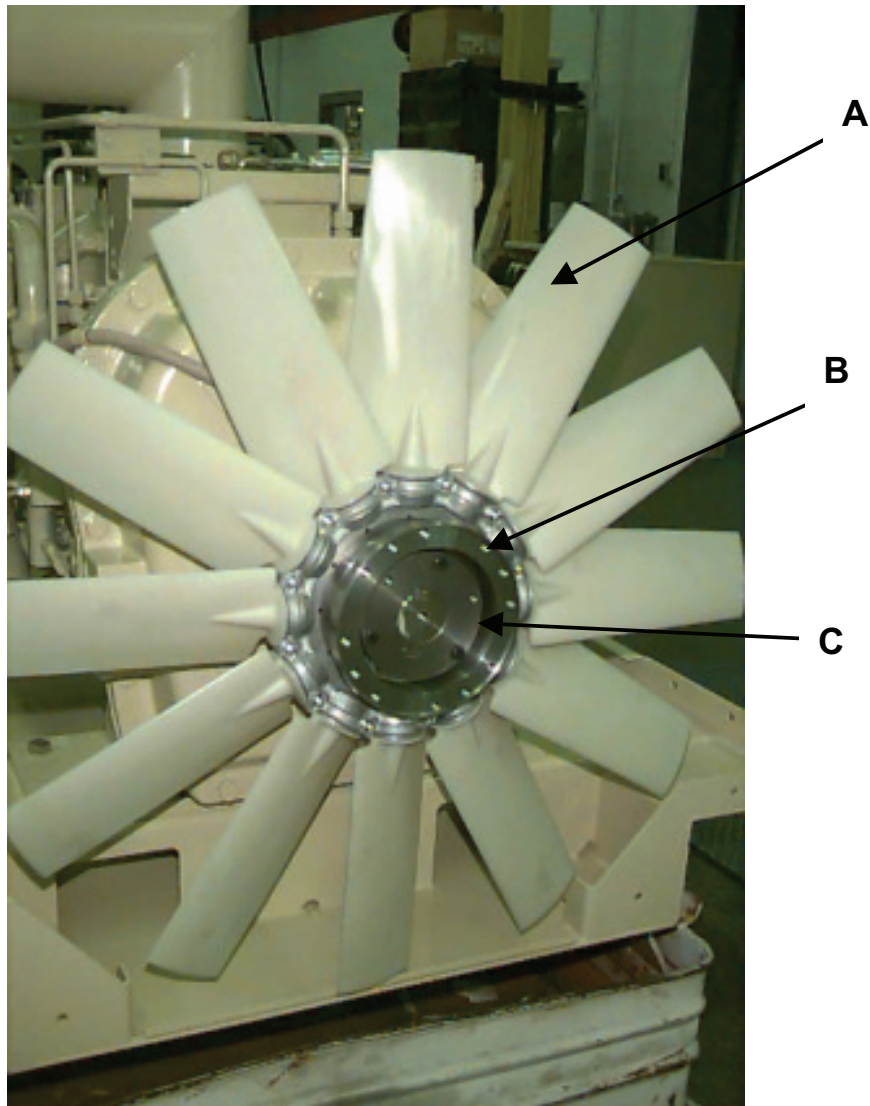

ITEM	PART NUMBER	DESCRIPTION
A	43211713	Fan, 36"
B	43211614	Hub, Drive
C	35103852	Bushing
D	35321108	Screw (6) Fan to Hub (Not shown)

COOLING FAN

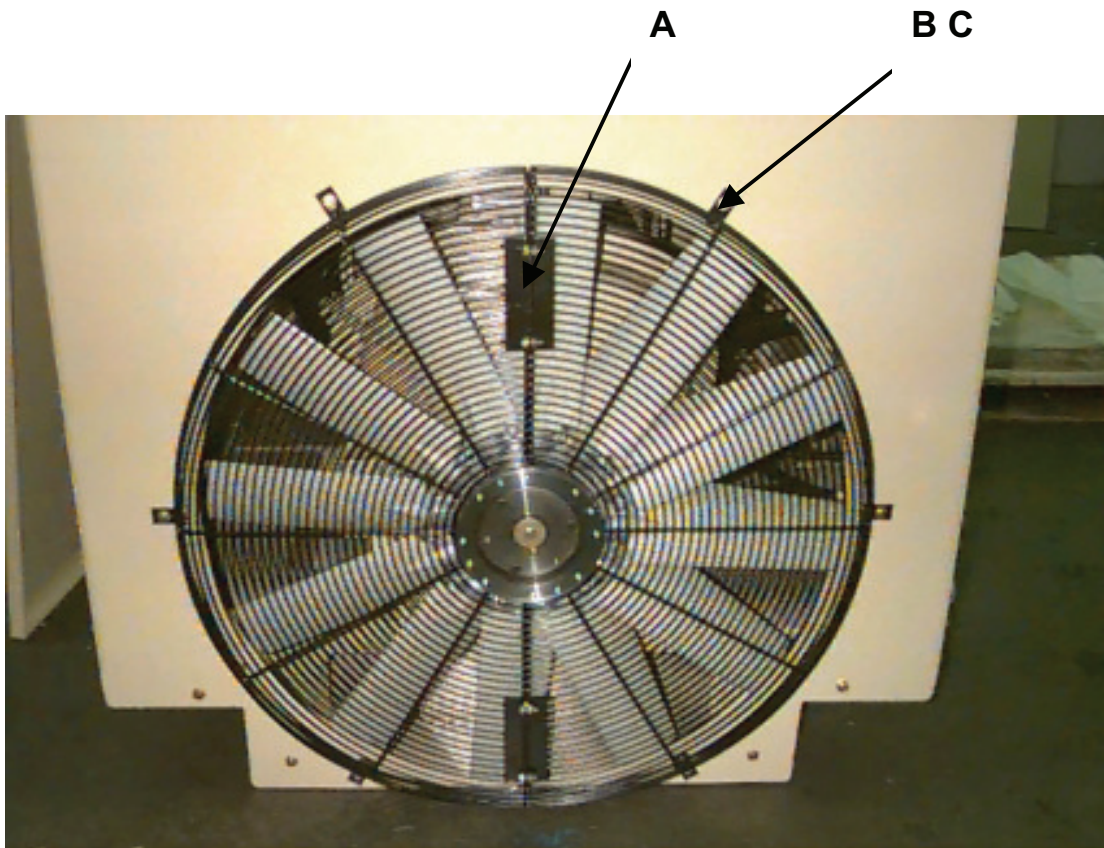

ITEM	PART NUMBER	DESCRIPTION
A	36870004	Fan Guard
B	35374834	Screw (6)
C	36895746	Nutsert (6) in End Panel

COOLING FAN

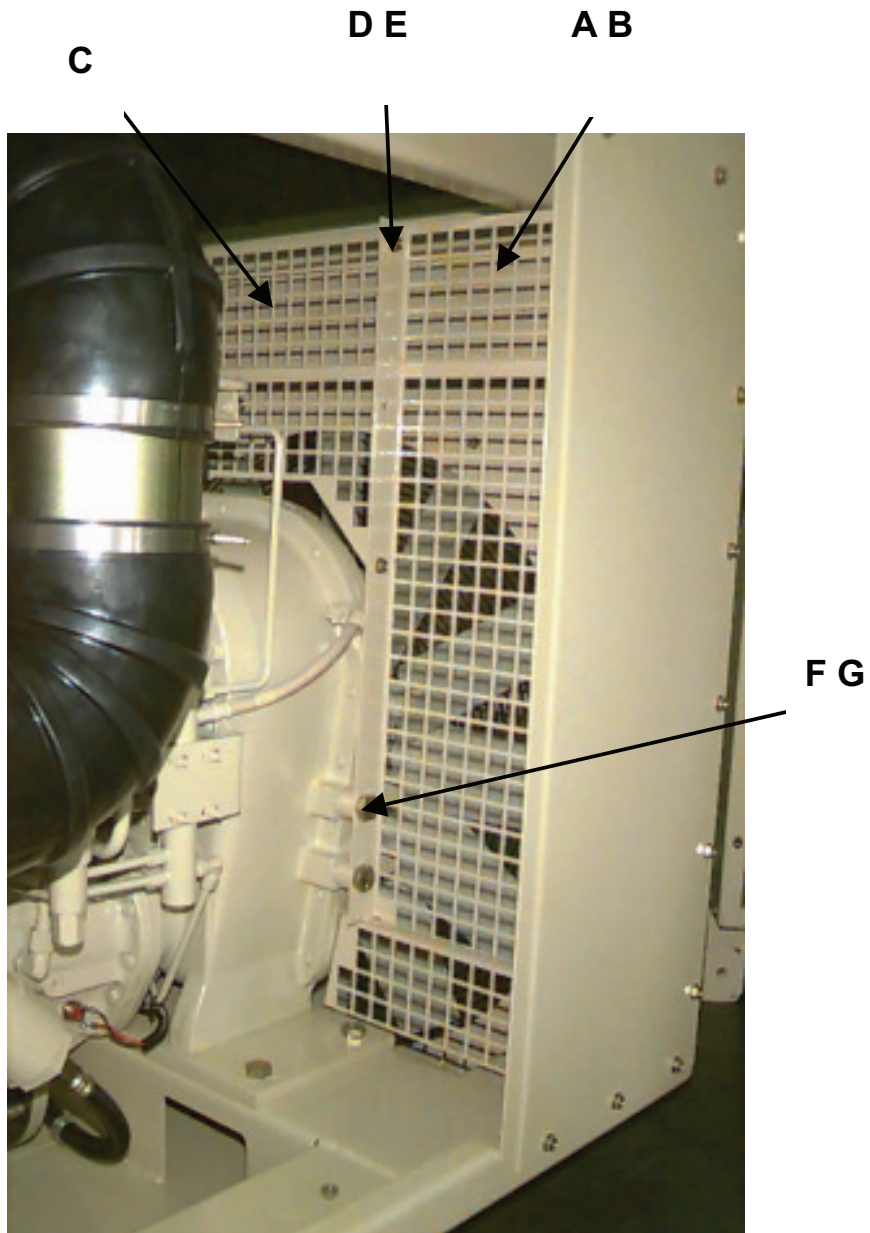

ITEM	PART NUMBER	DESCRIPTION
A	43212356	Guard, RH
B	43212364	Guard, LH (Opposite side shown)
C	43212372	Guard, Center
D	35144344	Bolt (4)
E	35145077	Nut (4)
F	36763670	Bolt (4)
G	36898450	Spacer (2) Cut in Half for Correct Length

OIL COOLER

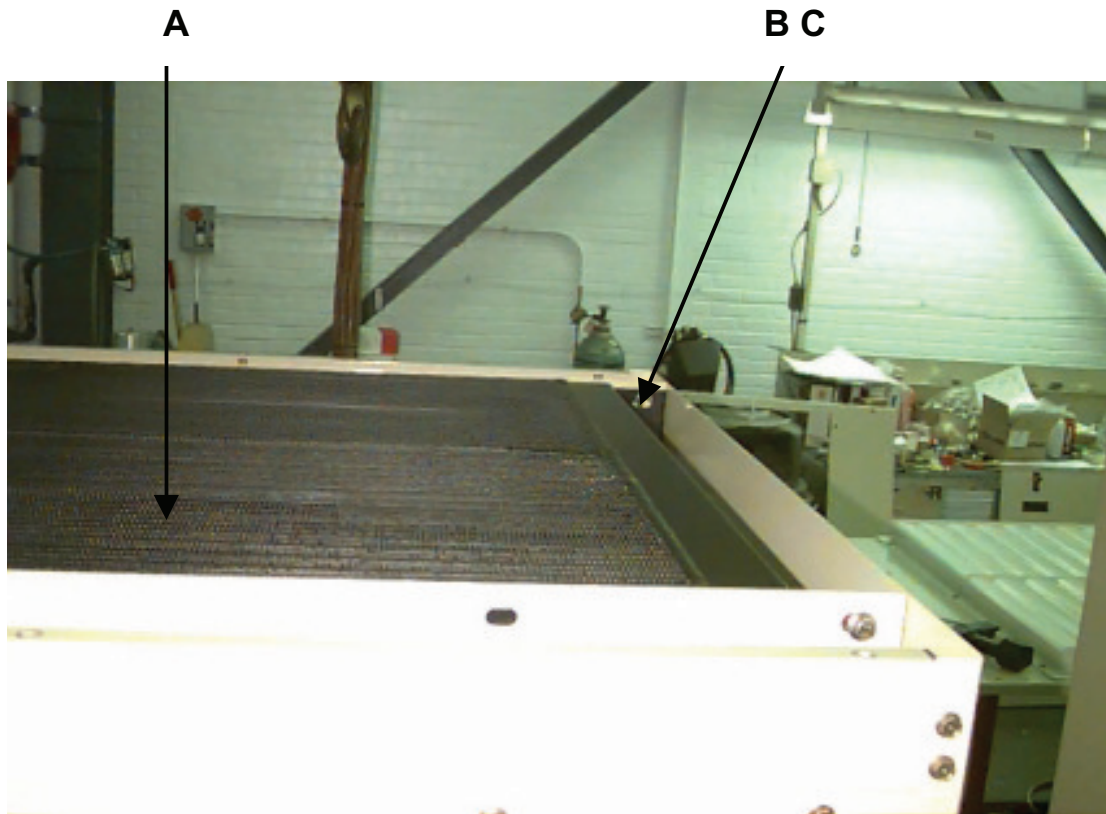

ITEM	PART NUMBER	DESCRIPTION
A	43211739	Oil Cooler
B	35252758	Bolt (8)
C	3252618	Nut (8)

SHUTTER ASSEMBLY

C D

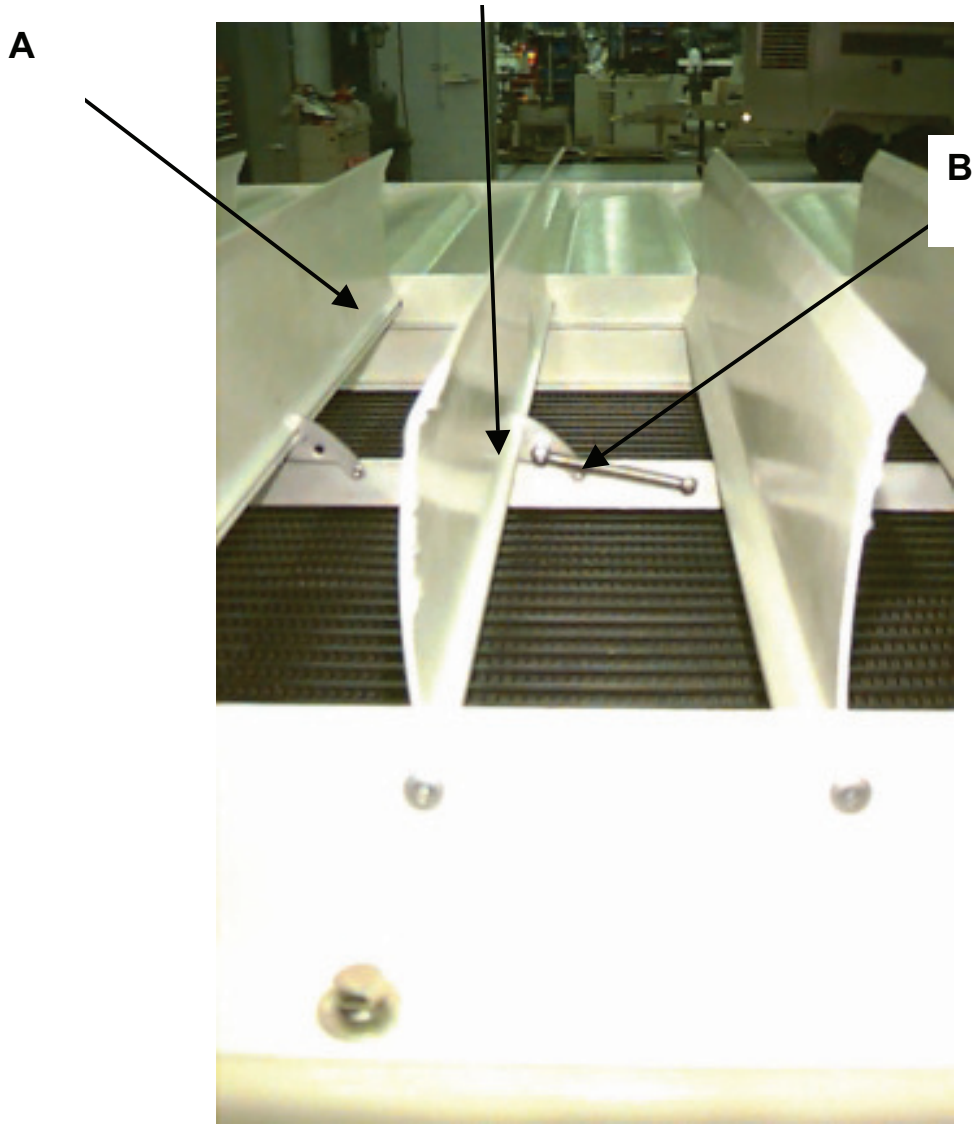

ITEM	PART NUMBER	DESCRIPTION
A	43212273	Shutter Assembly
B	43211978	Spring (2)
C	95942603	Screw SS (4)
D	95923124	Nut (4)

AIR FILTERS

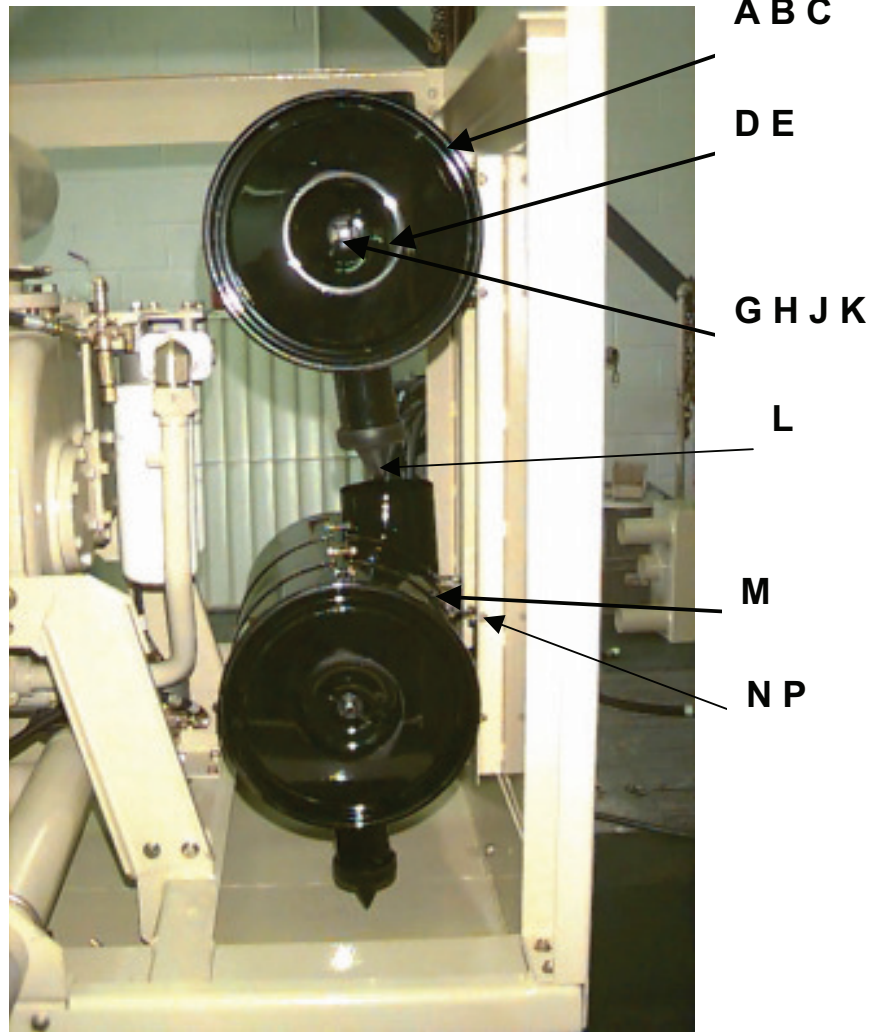

ITEM	PART NUMBER	DESCRIPTION
A	36845899	Air Filter
B	35384619	Element Primary
C	35384627	Element Safety
D	35384635	Cover
E	35384650	Gasket
G	35380856	Wingnut (cover)
H	35380864	Retainer (cover)
J	35380815	Wingnut (primary)
K	35384643	Nut Assembly (safety)
L	35380823	Valve Vacuator
M	35803147	Mounting Band (4)
N	35144344	Bolt (8)
P	35145077	Nut (8)

AIR FILTERS

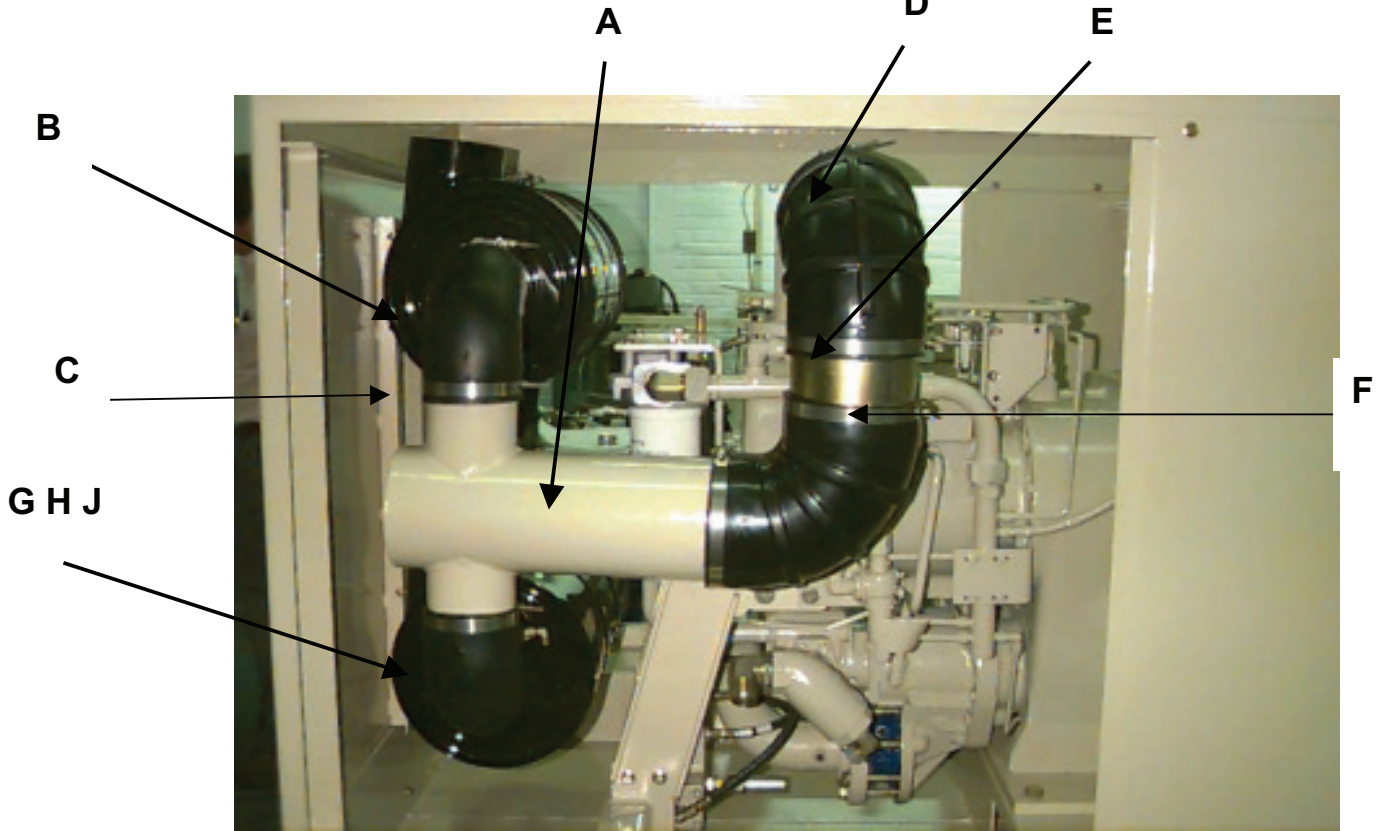

ITEM	PART NUMBER	DESCRIPTION
A	43211986	Plenum
B	35135300	Elbow (2)
C	35161025	Clamp (4)
D	35112630	Elbow (2)
E	35119858	Clamp (4)
F	36794964	Tube
G	95956199	Elbow 1/8p x 45
H	95287629	Adapter 1/8p x 4
J	35291269	Hose – 4 (to indicator)

INSTRUMENTATION

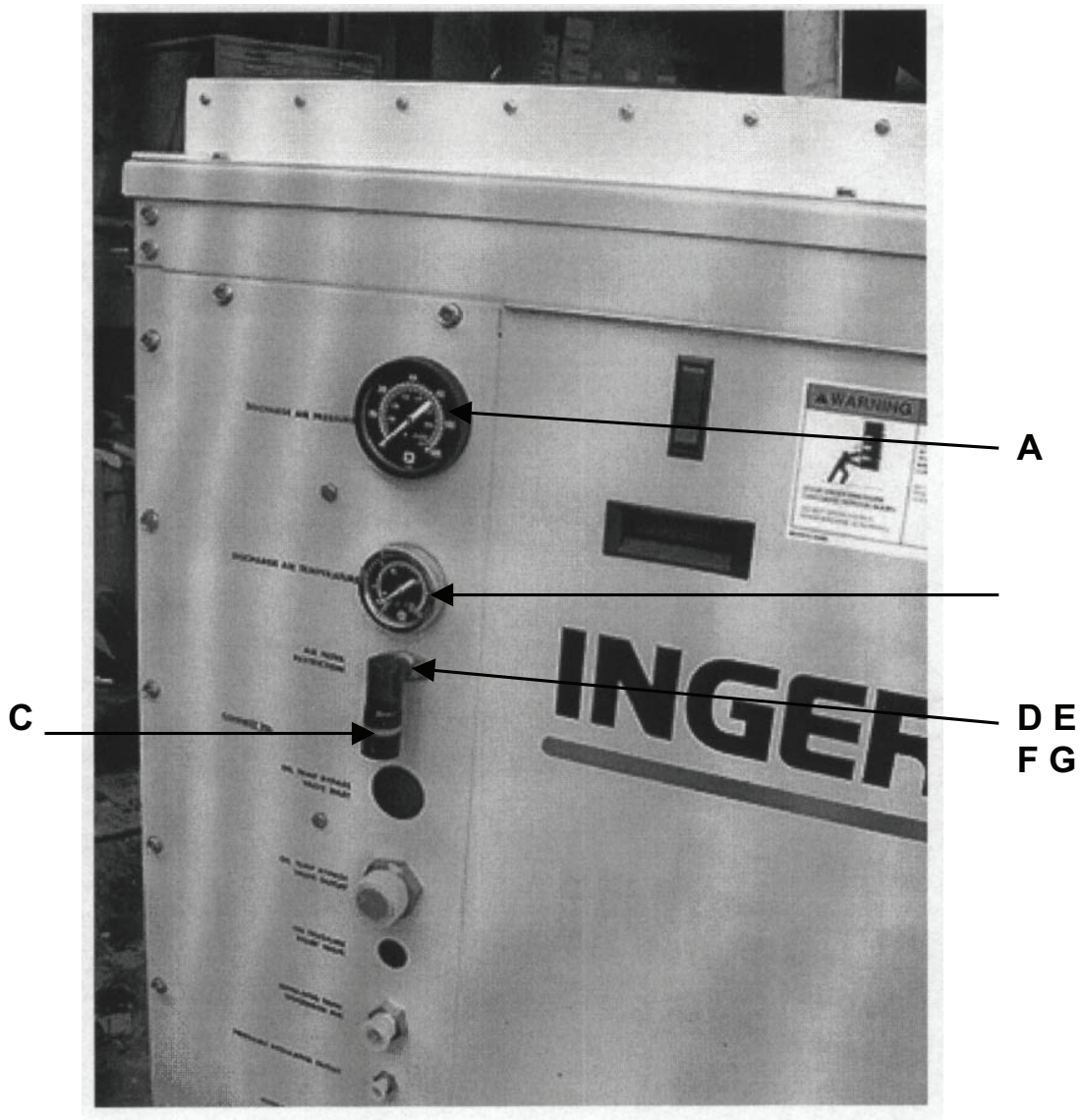

ITEM	PART NUMBER	DESCRIPTION
A	36841468	Gauge, Disch. Pressure
B	36765790	Gauge, Disch. Temperature
C	35107390	Indicator, Service – Air Cleaners
D	35107408	Flange
E	95287629	Adapter Hose (in back of Flange)
F	35144328	Screw (2)
G	35144492	Nut

SEPARATOR TANK ASSEMBLY

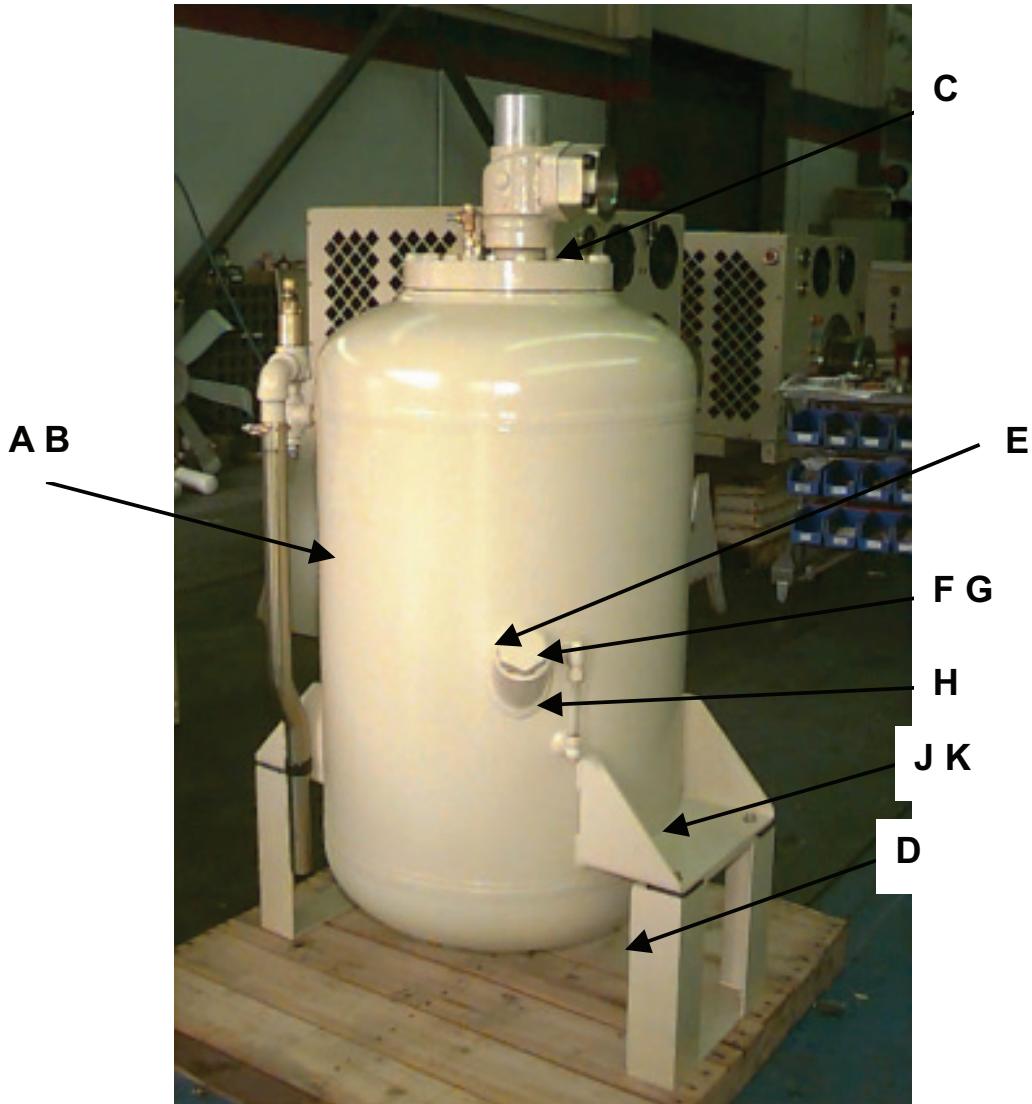

ITEM	PART NUMBER	DESCRIPTION
A	54469283	Separator Tank & Cover Assembly
B	36762250	Element, Separator
C	95935201	Bolt, Cover to Tank (12)
D	43204742	Bracket, Tank (2)
E	35802933	Plug, Oil Filter
F	36860468	Fittings, Sight Glass
G	35324649	Gasket, Sight Gauge
H	36845444	Tube, Sight Gauge
J	36877793	Bolt (4)
K	36879203	Nut (4)

SEPARATOR TANK ASSEMBLY

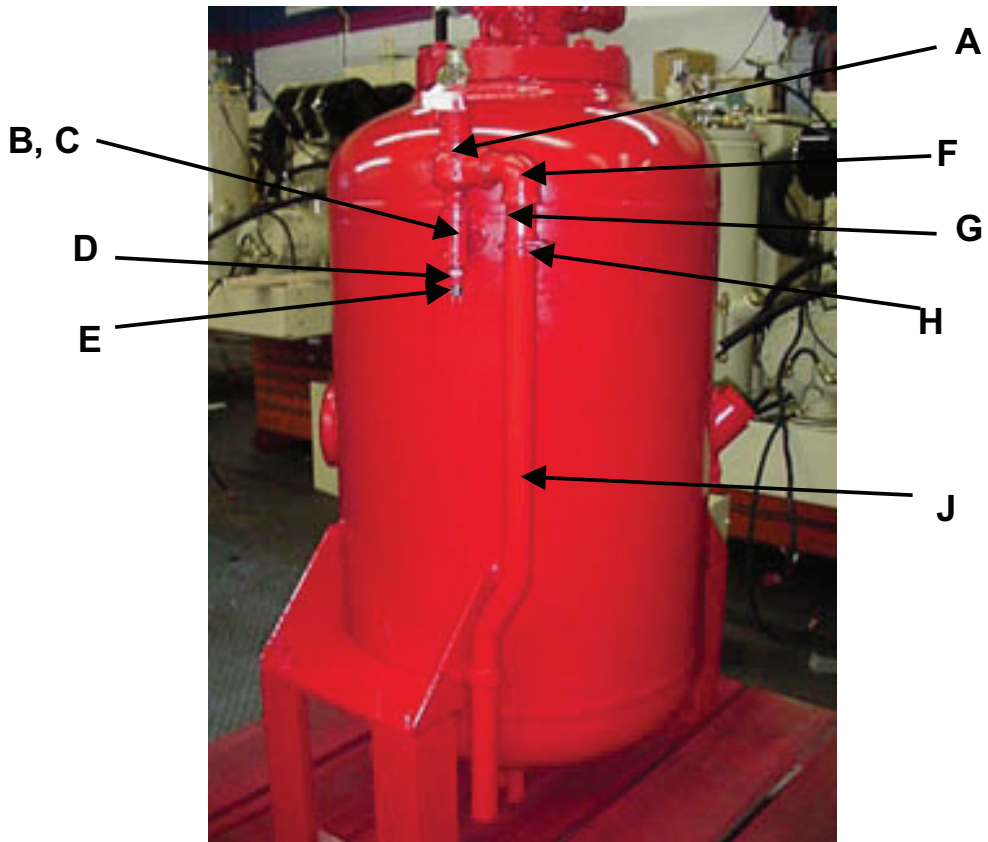

ITEM	PART NUMBER	DESCRIPTION
A	35596733	Safety Valve
B	95953410	Tee
C	95928040	Nipple (Tee to Tank)
D	95953949	Bushing
E	36865756	Switch, Temperature
F	95944104	Elbow, 90° ST
G	36762821	Nipple
H	35261155	Clamp
K	36764868	Pipe

SEPARATOR TANK ASSEMBLY

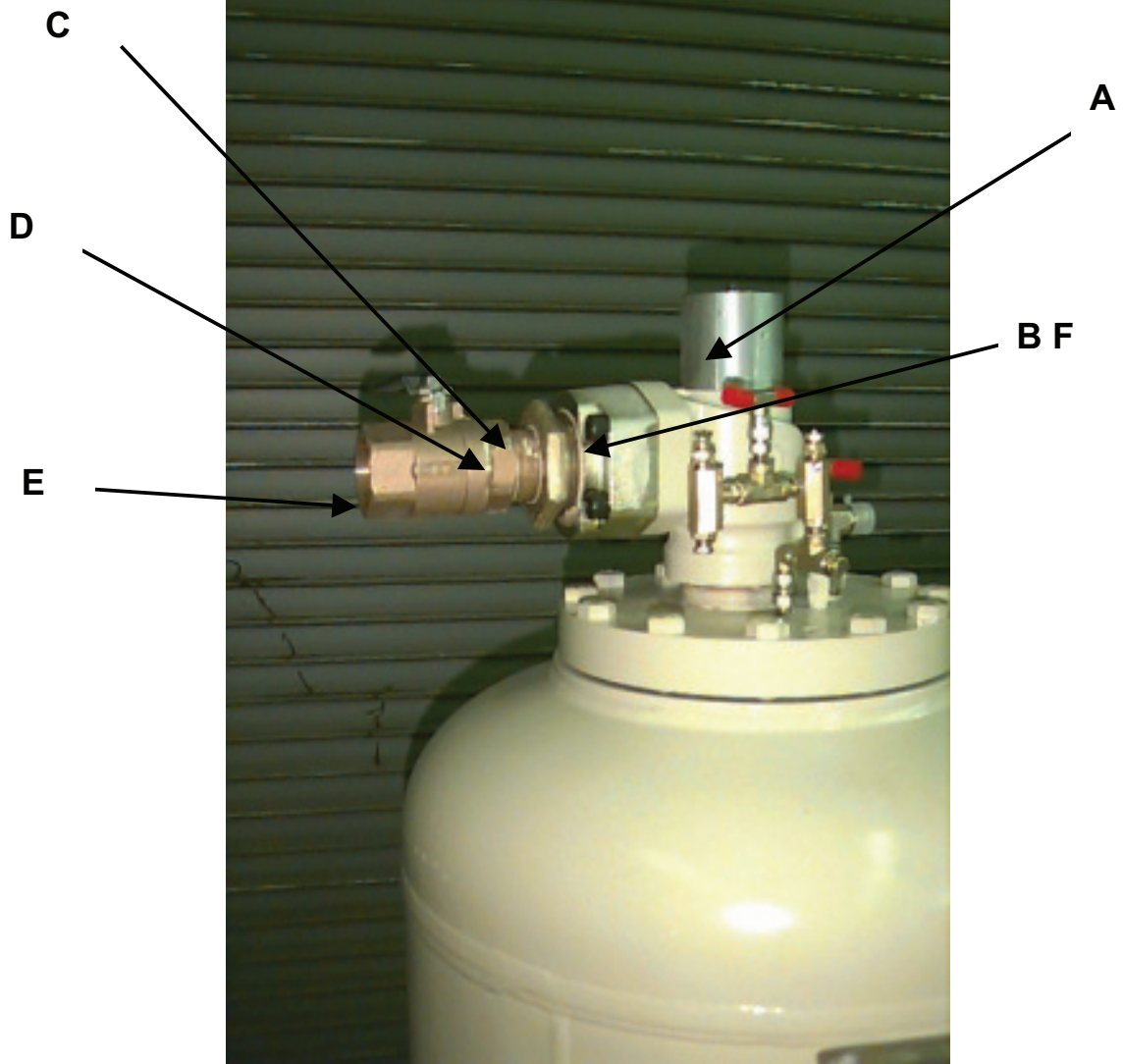

ITEM	PART NUMBER	DESCRIPTION
A	36762268	Minimum Pressure Valve
B	36893220	Flange, Adapter
C	95951398	Bushing, Reducing
D	95091625	Nipple, 2" NPT
E	35602473	Ball Valve, 2" NPT
F	95358040	O-Ring

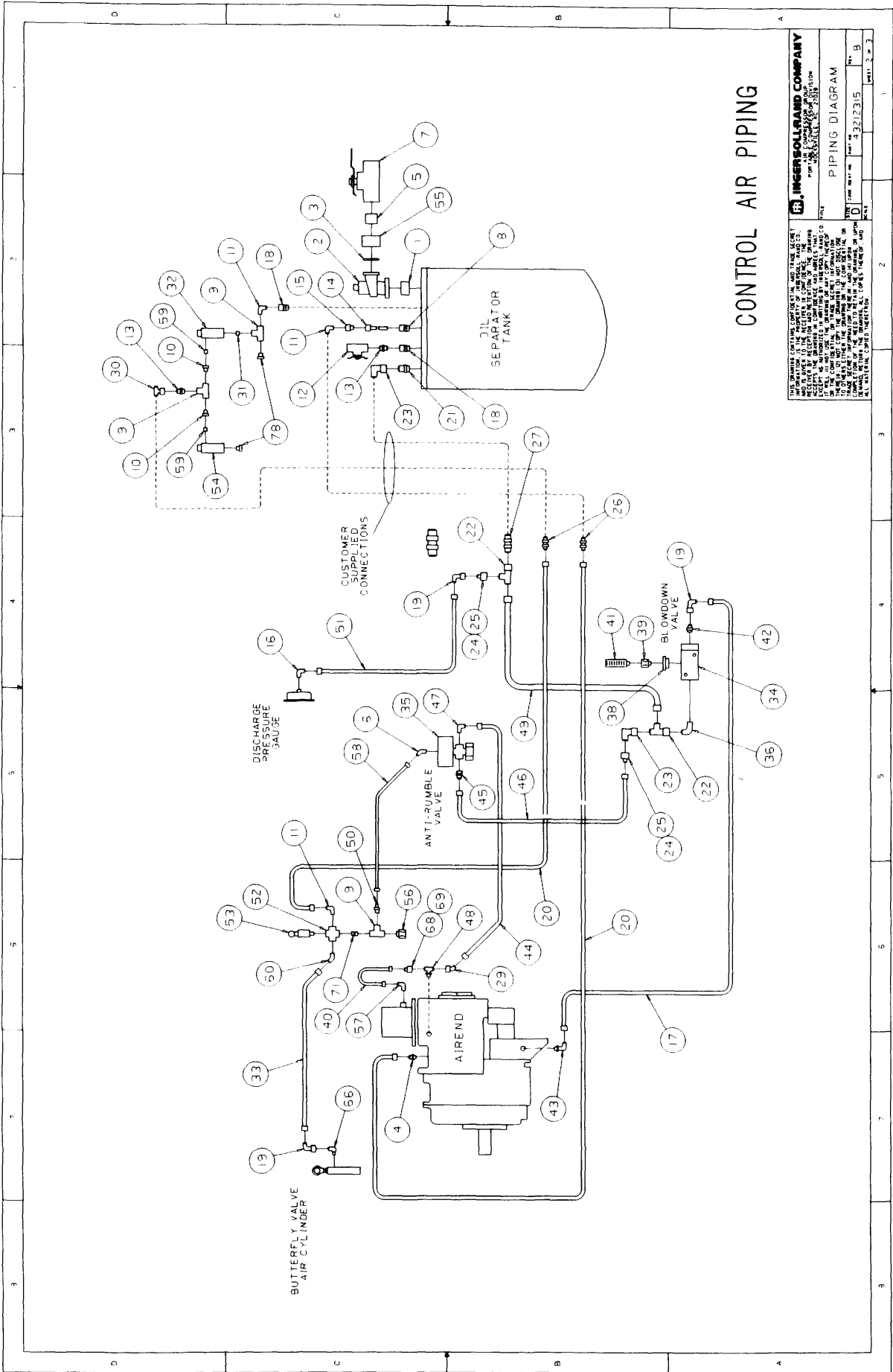

CONTROL AIR PIPING

INGERSOLL RAND COMPANY PIPING & VALVE DEPARTMENT 1000 WEST 17TH AVENUE DENVER, COLORADO 80202	
TITLE PIPING DIAGRAM	DRAWING NO. 3212315
SHEET NO. 2 OF 3	DATE 11/81

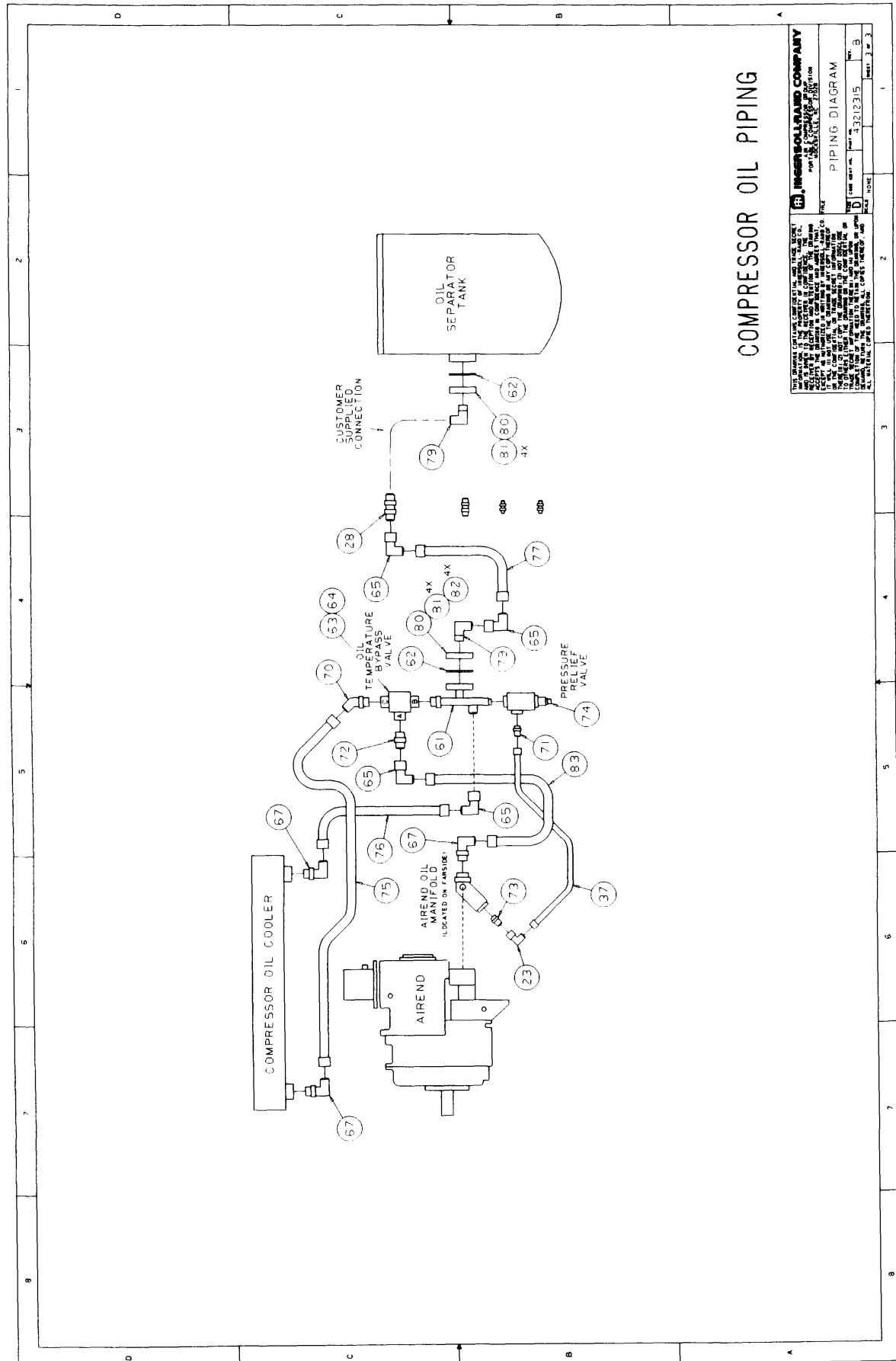

JAMES HOLLAND COMPANY
 PIPELINE & INDUSTRIAL DIVISION
 PIPING DIAGRAM
 FILE NO. 43212315
 SHEET 3 OF 3

COMPRESSOR OIL PIPING

OIL PIPING

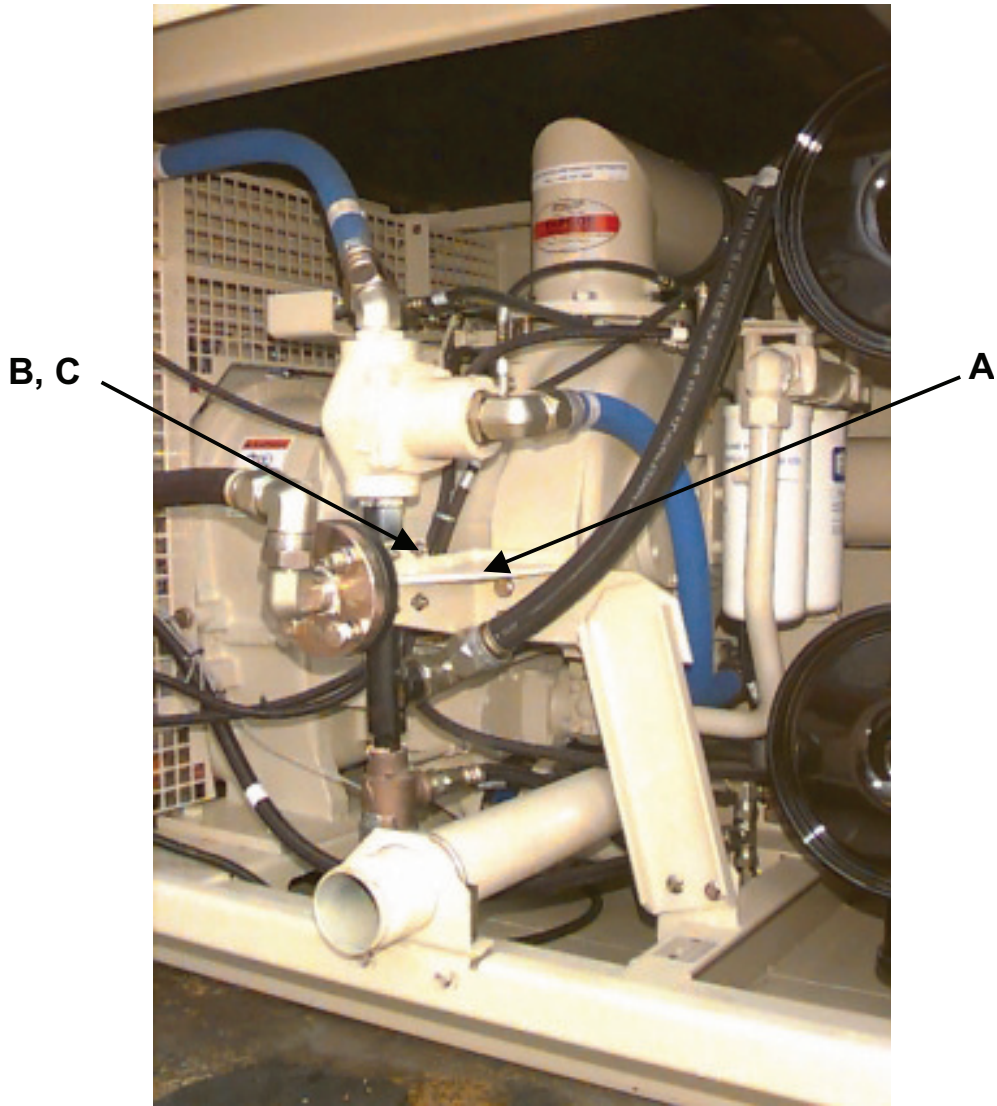

ITEM	PART NUMBER	DESCRIPTION
A	43212992	Bracket, Oil Temp. Bypass Valve
B	35261155	Clamp (2x)
C	95094306	Washer (4x)

AIR PIPING

C D E

A

F G

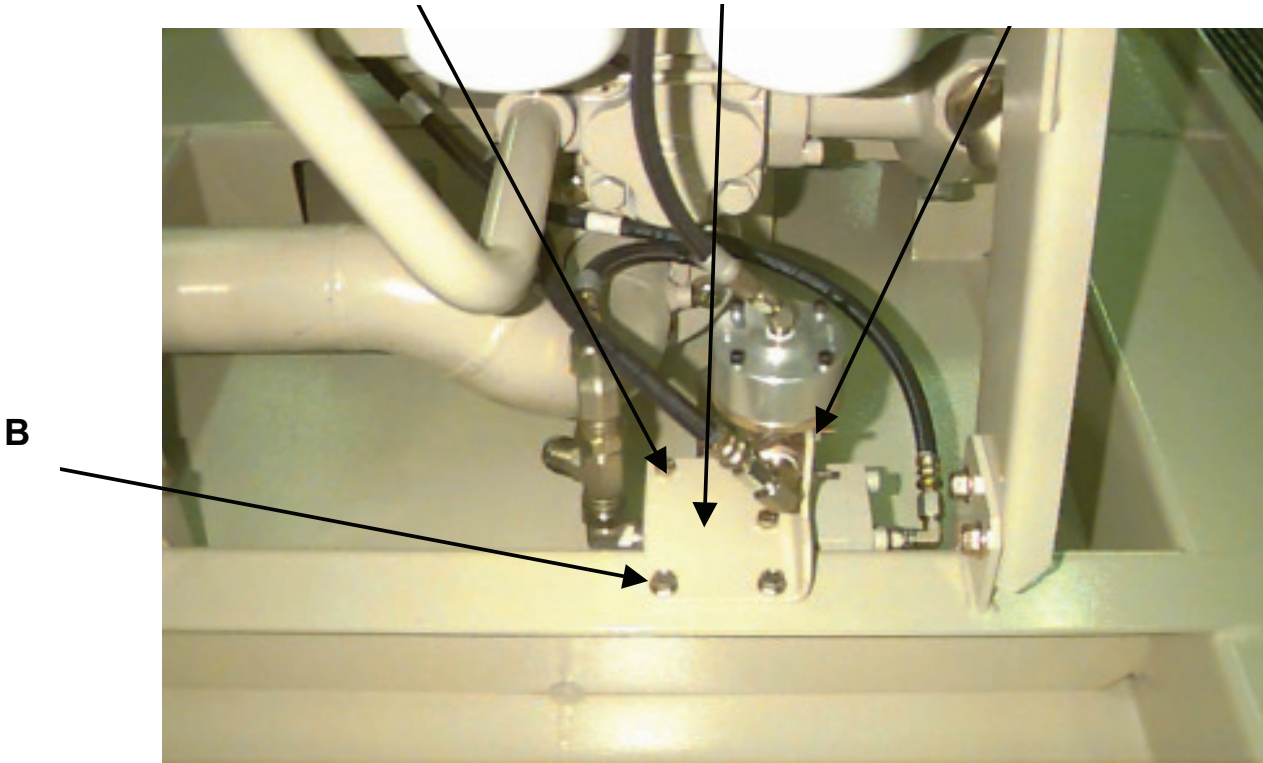

ITEM	PART NUMBER	DESCRIPTION
A	36842532	Bracket, Blowdown Valve
B	35134550	Screw Tapping (2)
C	95934618	Bolt (2-Bldn valve to brkt)
D	95935037	Washer (2-Bldn valve to brkt)
E	35145077	Nut (2-Bldn valve to brkt)
F	35166404	U-Bolt (2)
G	35144492	Nut (4)

AIR PIPING

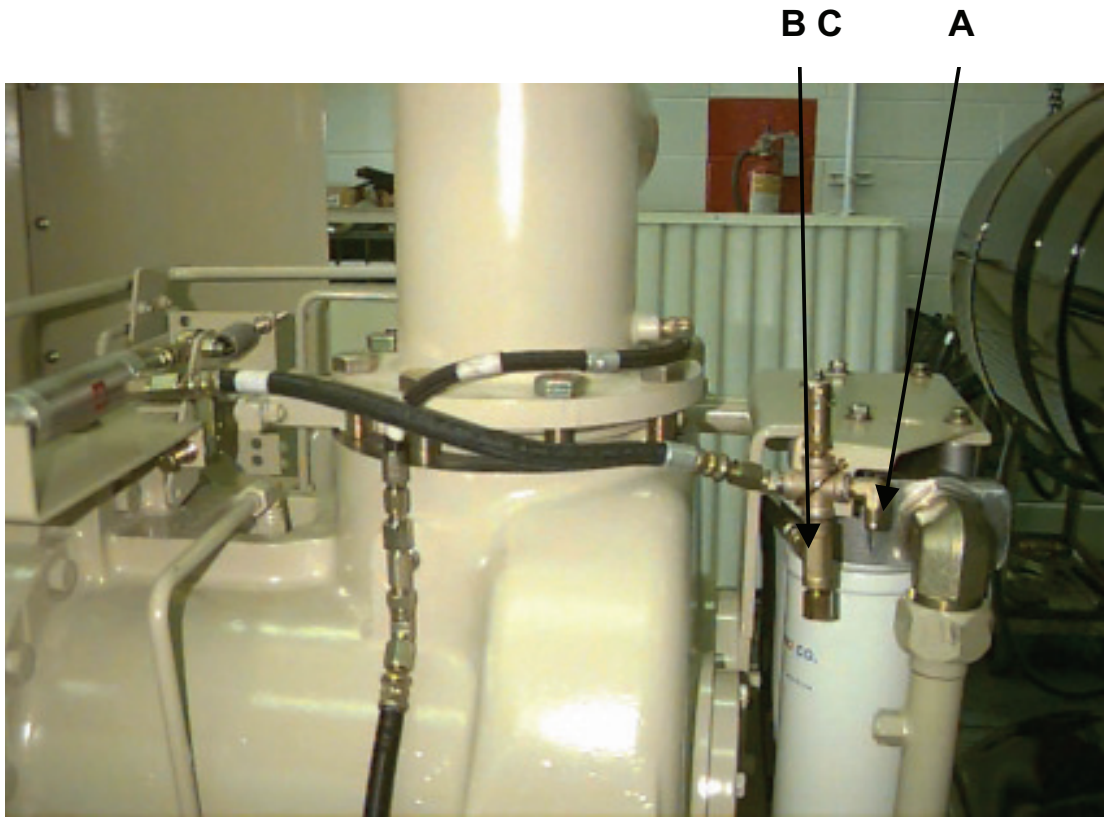

ITEM	PART NUMBER	DESCRIPTION
A	36842565	Bracket
B	35166404	U-Bolt
C	35144492	Nut (2)

DECALS

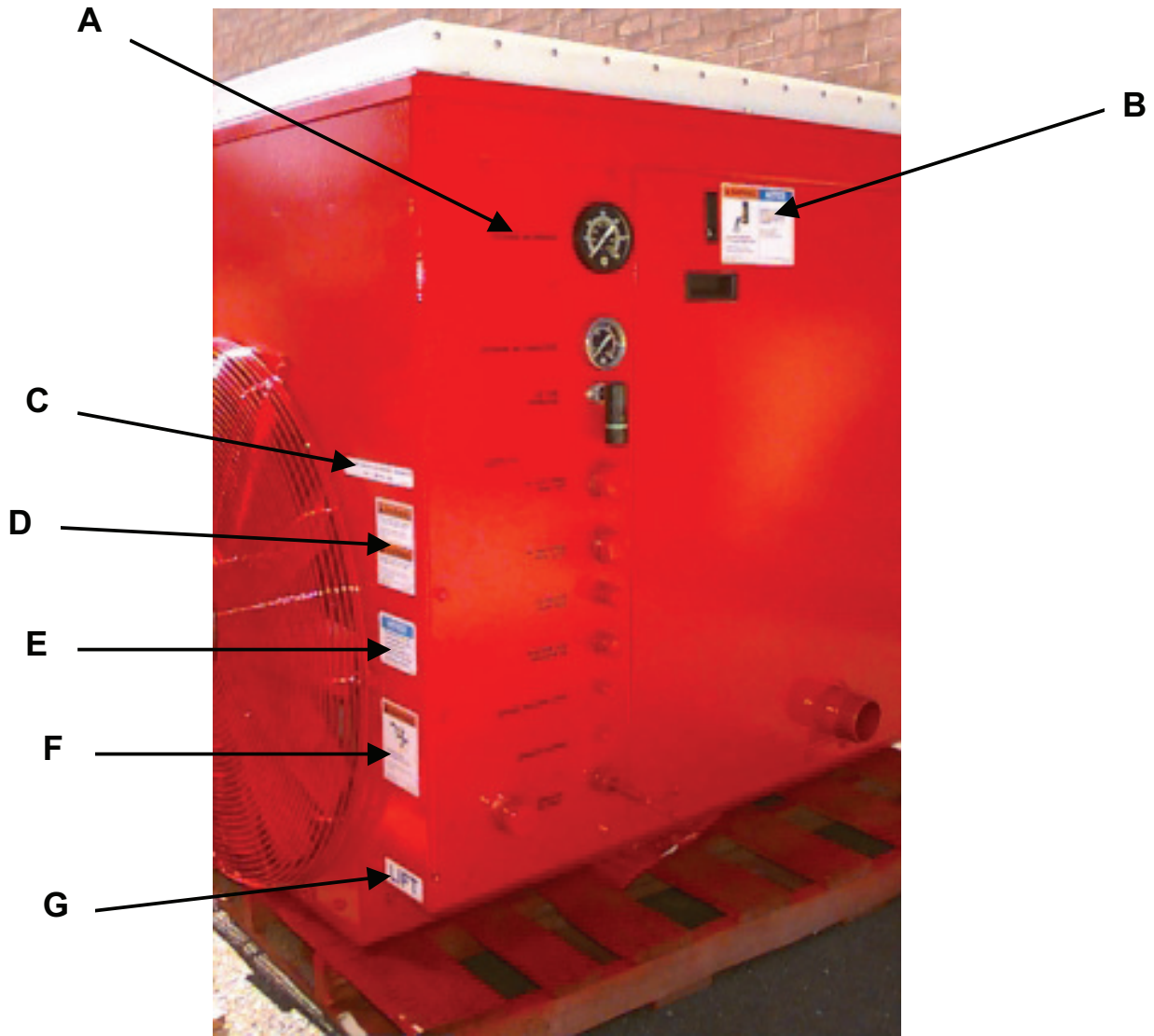

ITEM	PART NUMBER	DESCRIPTION
A	43212349	Interface Markings Decal
B	43212604	
C	36534832	Warning/Notice: Door Under Pressure
D	36522035	Service Decal
E	36520310	Warning: Improper Operation
F	36522050	Notice: Dropping
G	36513026	Warning: Rotating Fan (2)
		Lift Decal (4)

DECALS

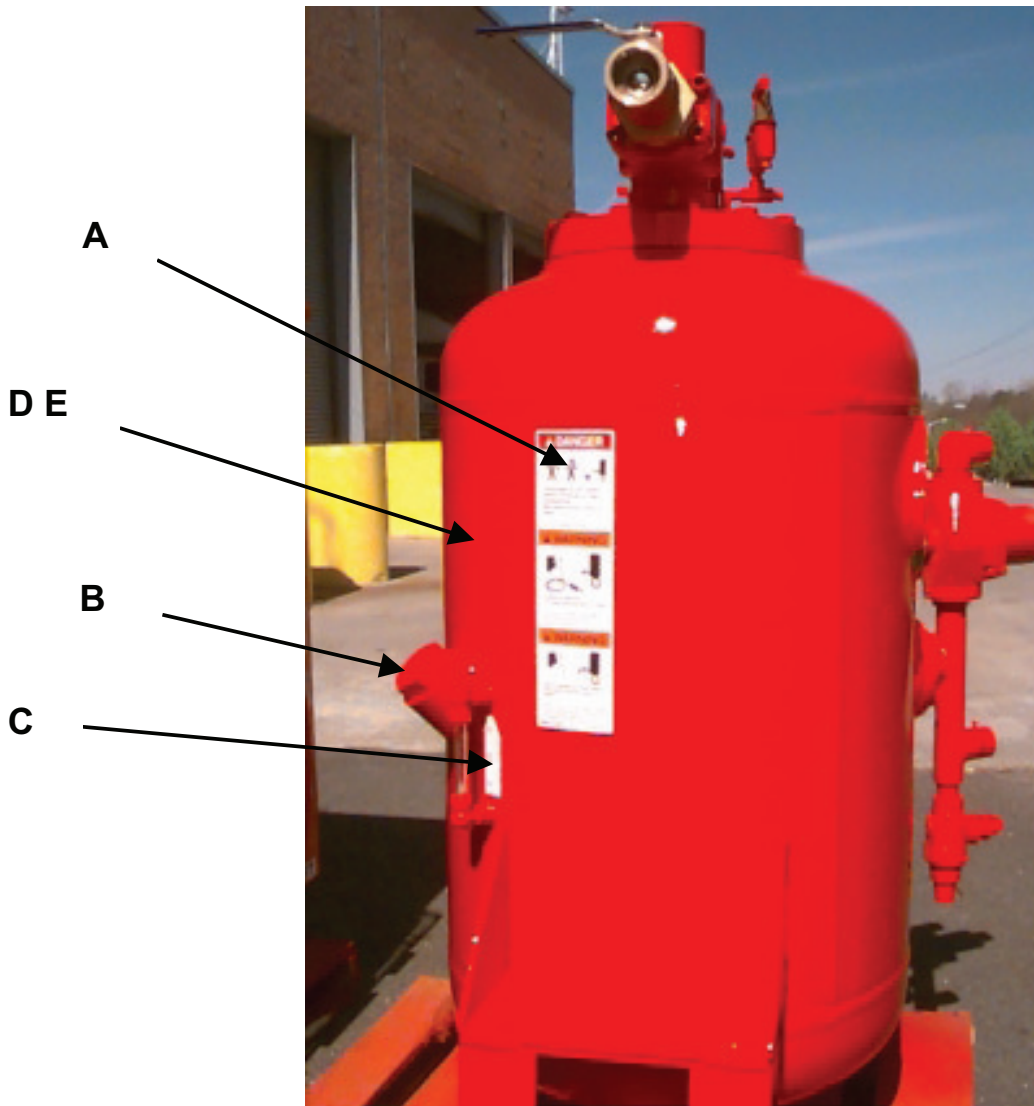

ITEM	PART NUMBER	DESCRIPTION
A	36532018	Danger/Warning: 3 part Decal
B	36534956	Oil Fill Decal (this location)
C	36512739	Oil Level Decal
D	36535185	Pro-Tec Lubricant Decal (this location)
E	36534840	Extended Warranty (this location)

DECALS

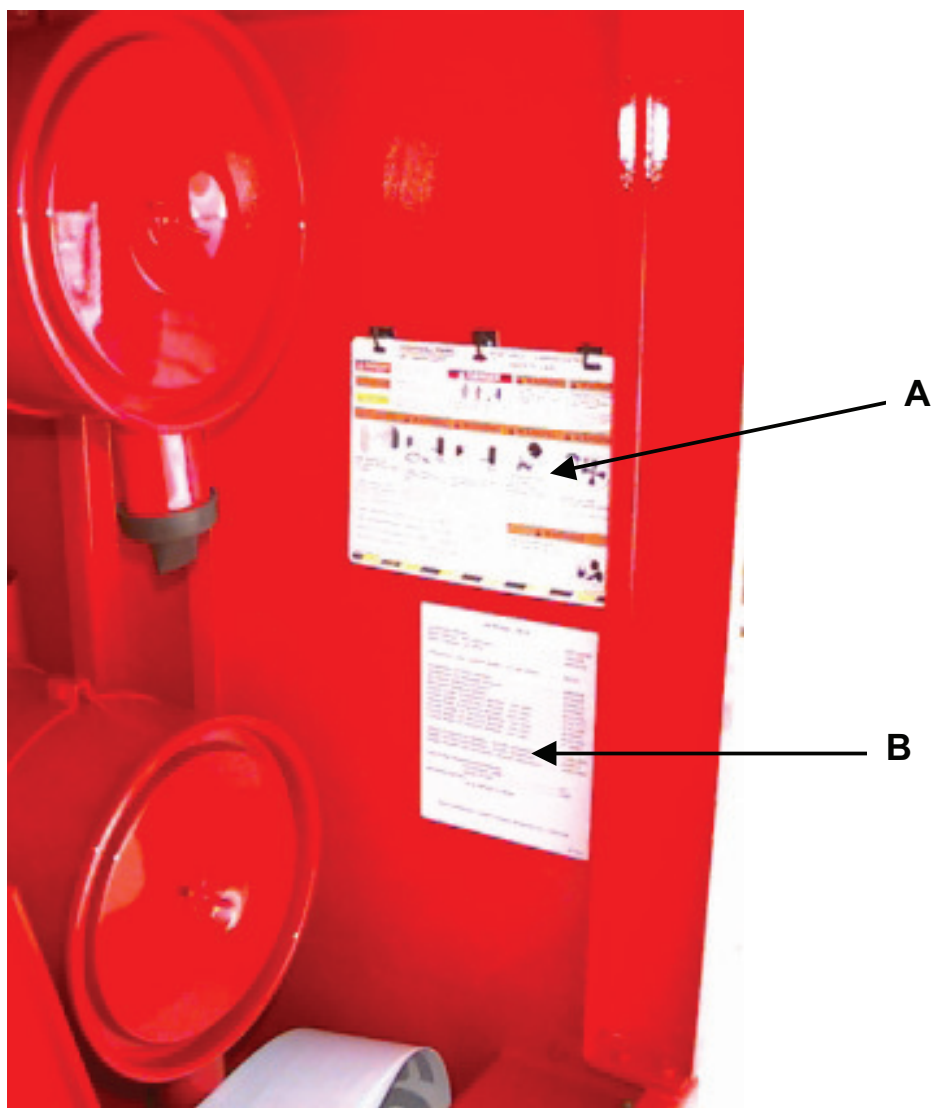

ITEM	PART NUMBER	DESCRIPTION
A	36522290	Safety Card
B	43215102	General Data Decal

DECALS

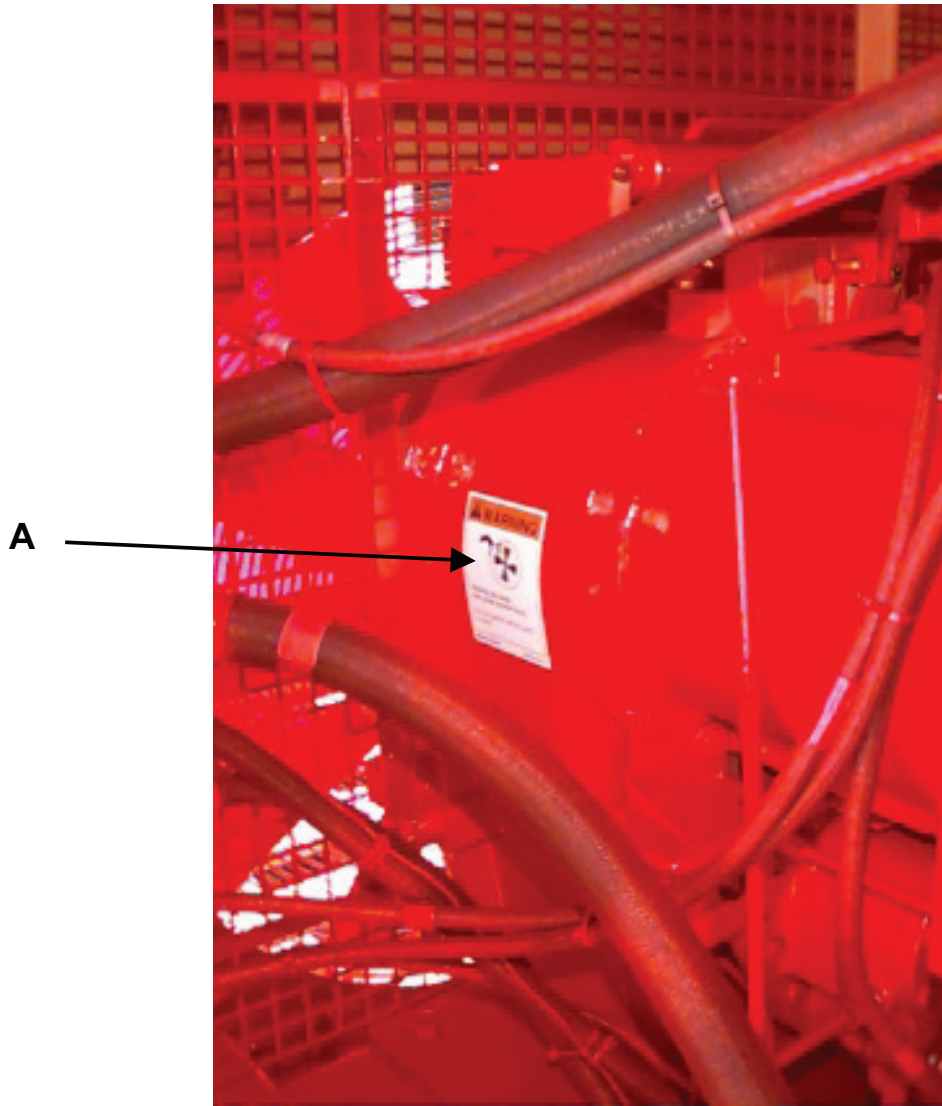

ITEM	PART NUMBER	DESCRIPTION
A	36522050	Warning: Rotating Fan (2)

DECALS



ITEM	PART NUMBER	DESCRIPTION
A	36527810	I-R Signature (1 ea. Side)

SECTION 11 – COMMON FASTENERS

Contents	Page	Contents	Page
Table 1 – SAE/Inch	1	Table 2 – ISO/Metric	3
Screws	1	Screws, Nuts & Washers	3
Nuts & Washers	2	Grade Identification	3
Grade Identification	2		







**Table 1
SAE/Inch Screws**

Part Number	Size	Description	Part Number	Size	Description
109A2A311N	#10-24 UNC-3A x 1/4"	Hex Socket Head (Nylon Insert)	35A2D386	3/4"-10 UNC-2A x 4"	Hex Head
119A2A146	1/4"-20 UNC-3A x 1/4"	Hex Socket Head	35A2D388	3/4"-10 UNC-2A x 4 1/2"	Hex Head
119A2A148	1/4"-20 UNC-3A x 1/8"	Hex Socket Head	35A2D390	3/4"-10 UNC-2A x 5"	Hex Head
119A2A198N	1/8"-16 UNC-3A x 1/4"	Hex Socket Head (Nylon Insert)	35A2D4	1/4"-20 UNC-2A x 7/8"	Hex Head
119A2A206N	1/4"-16 UNC-3A x 2"	Hex Socket Head (Nylon Insert)	35A2D5	5/16"-18 UNC-2A x 3"	Hex Head
119A2A251	1/2"-13 UNC-3A x 1 1/4"	Hex Socket Head	35A2D54	5/16"-18 UNC-2A x 1/2"	Hex Head
121A2A175	1/8"-16 UNC – 3A x 1"	Hex Socket Head	35A2D57	5/16"-18 UNC-2A x 7/8"	Hex Head
125A2C1012	#310-24 UNC-3A x 1 1/4"	Hex Socket Head	35A2D58	5/16"-18 UNC-2A x 1"	Hex Head
133A2C44	#4-40 UNC – 3A x 1/2"	Hex Socket Head	35A2D60	5/16"-18 UNC-2A x 1	Hex Head
35A2D110	1/8"-16 UNC-2A x 7/8"	Hex Head	35A2D62	1/4"	Hex Head
35A2D111	1/8"-16 UNC-2A x 1"	Hex Head	35A2D64	5/16"-18 UNC-2A x 1	Hex Head
35A2D112	1/8"-16 UNC-2A x 1 1/8"	Hex Head	35A2D7	1/2"	Hex Head
35A2D113	1/8"-16 UNC-2A x 1 1/4"	Hex Head	35A2D8	5/16"-18 UNC-2A x 2"	Hex Head
35A2D117	1/8"-16 UNC-2A x 2"	Hex Head	35130293	1/4"-20 UNC-2A x 1 1/4"	Hex Head
35A2D118	1/8"-16 UNC-2A x 2 1/4"	Hex Head	35130301	1/4"-20 UNC-2A x 1 3/8"	Self-Tapping Hex Head
35A2D119	1/8"-16 UNC-2A x 2 1/2"	Hex Head		3/8"-16 x 3/4"	Self-Tapping Hex Head
35A2D120	1/8"-16 UNC-2A x 2 3/4"	Hex Head	35141365	5/16"-18 x 3/4"	Hex Head
35A2D122	1/8"-16 UNC-2A x 3 1/4"	Hex Head		5/16"-18 x 1/2"	Self-Tapping Whiz-Lock®
35A2D127	1/8"-16 UNC-2A x 4 1/2"	Hex Head	35144328	5/16"-18 x 1/2"	Whiz-Lock®
35A2D131	1/8"-16 UNC-2A x 6"	Hex Head	35144336	1/4"-20 x 5/8"	Whiz-Lock®
35A2D168	7/16"-14 UNC-2A x 1 1/2"	Hex Head	35144344	1/4"-20 x 5/8"	Whiz-Lock®
35A2D174	7/16"-14 UNC-2A x 3"	Hex Head	35144484	5/16"-18 x 3/4"	Whiz-Lock®
35A2D215	1/2"-13 UNC-2A x 3/4"	Hex Head	35145242	3/8"-16 x 1"	Whiz-Lock®
35A2D216	1/2"-13 UNC-2A x 7/8"	Hex Head	35148030	1/4"-20 x 1"	Whiz-Lock®
35A2D217	1/2"-13 UNC-2A x 1"	Hex Head		1/4"-20 x 1 1/4"	Hex Head
35A2D219	1/2"-13 UNC-2A x 1 1/4"	Hex Head	35252451	1/2"-13 x 1"	Self-Tapping Whiz-Lock®
35A2D221	1/2"-13 UNC-2A x 1 1/2"	Hex Head	35252493	1/2"-13 x 1"	Whiz-Lock®
35A2D223	1/2"-13 UNC-2A x 2"	Hex Head	35252568	1/4"-20 x 1"	Whiz-Lock®
35A2D229	1/2"-13 UNC-2A x 3 1/2"	Hex Head	35252741	3/8"-16 x 3/4"	Whiz-Lock®
35A2D231	1/2"-13 UNC 2A x 4"	Hex Head	35252758	1/2"-13 x 1 1/4"	Whiz-Lock®
35A2D232	1/2"-13 UNC-2A x 4 1/4"	Hex Head	35287119	1/2"-13 x 1 1/2"	Whiz-Lock®
35A2D3	1/4"-20 UNC-2A x 3/4"	Hex Head		1/2"-13 x 1"	Hex Head
35A2D323	5/8"-11 UNC-2A x 1 1/4"	Hex Head	35321108	1/4"-14 x 3/4"	Self-Tapping Whiz-Lock®
35A2D325	5/8"-11 UNC-2A x 1 1/2"	Hex Head	35334879	5/16"-18 x 1"	Whiz-Lock®
35A2D326	5/8"-11 UNC-2A x 1 3/4"	Hex Head		5/16"-18 x 1"	Hex Head
35A2D327	5/8"-11 UNC-2A x 2"	Hex Head	36A2A275	5/16"-18 x 1"	Self-Tapping Hex Head
35A2D328	5/8"-11 UNC-2A x 2 1/4"	Hex Head	87A2C93P	5/16"-18 x 2"	Round Head Phillips
35A2D329	5/8"-11 UNC 2A x 2 1/2"	Hex Head		5/16"-18 x 2"	Round Head Phillips
35A2D330	5/8"-11 UNC 2A x 2 3/4"	Hex Head	95095659	10-24 x 1/8"	Phillips
35A2D331	5/8"-11 UNC 2A x 1 1/3"	Hex Head		10-24 x 1/2"	Phillips
35A2D380	3/4"-10 UNC-2A x 2 1/2"	Hex Head			
35A2D382	3/4"-10 UNC-2A x 3"	Hex Head			
35A2D384	3/4"-10 UNC-2A x 3 1/2"	Hex Head			

Whiz-Lock® is a Registered T.M. of MacLean-Fogg Nut Co.
(Alternate Suppliers are Acceptable for this Part Number)

Part Number	Size	Description	Part Number	Size	Description
16A4C1	¼"-20 UNC-2B	Hex	11A5C1	#10	Flat (Commercial)
16A4C2	5/16"-18 UNC-2B	Hex	11A5C2	¼"	Flat (Commercial)
16A4C3	¾"-16 UNC-2B	Hex	11A5C3	3/16"	Flat (Commercial)
16A4C5	½"-13 UNC-2B	Hex	11A5C4	3/8"	Flat (Commercial)
16A4C7	5/8"-11 UNC-2B	Hex	11A5C6	½"	Flat (Commercial)
16A4C8	¾"-10 UNC-2B	Hex	11A5C8	5/8"	Flat (Commercial)
16A4H7	5/8"-11 UNC-2B	Hex	12A5C2	¼"	Flat (SAE)
21A4C10	12-24 UNC 2B	Hex	12A5C3	5/16"	Flat (SAE)
21A4C5	4-40 UNC-2B	Hex	12A5C4	5/8"	Flat (SAE)
21A4C8	8-32 UNC-2B	Hex	12A5C6	½"	Flat (SAE)
21A4C9	10-24 UNC-2B	Hex	12A5C13	1.25"	Flat (SAE)
22A4C1	½"-28 UNC-2B	Hex	12A5C15	1.50"	Flat (SAE)
22A4C2	5/16"-24 UNF-2B	Hex	12A5D24	#10	Flat (SAE)
22A4C3	3/8"-24 UNC-2B	Hex	14A5C101	½"	Spring Lock
22A4C5	½"-20 UNC -2B	Hex	14A5C110	9/16"	Spring Lock
23A4C3	3/8"-24 UNC-2B	Hex	14A5C119	5/8"	Spring Lock
23A4C4	7/16"-20 UNC-2B	Hex	14A5 120	5/8"	Spring Lock
23A4C5	½"-20 UNC-2B	Hex	14A5C133	¾"	Spring Lock
23A4C8	¾"-16 UNC-2B	Hex	14A5C28	#8	Spring Lock
35144492	¼"-20	Whiz-Lock®	14A5C36	#10	Spring Lock
35145077	3/8"-16	Whiz-Lock®	14A5C55	¼"	Spring Lock
35252600	5/16"-18	Whiz-Lock®	14A5C55P	¼"	Spring Lock, Cadmium Plate
35252618	½"-13	Whiz-Lock®	14A5C65	5/16"	Spring Lock
35265388	10-24	Whiz-Lock®	14A5C65P	5/16"	Spring Lock, Cadmium Plate
35321504	5/8"-11	Hex	14A5C76	3/8"	Spring Lock
35326420	½"-13	Hex	14A5C9	#4	Spring Lock
35332980	½"-13	Hex	14A5C91	7/16"	Spring Lock
35336700	9/16"-18	Torque/Grade 8	35326233	3/8"	Spring Lock
66A4C3	3/8"-24	Nyloc			
66A4C5	1/4"-20	Nyloc			
67A4C1	¼"-20	Nyloc			
67A4C2	5/16"-18	Nyloc			
67A4C3	3/8"-16	Nyloc			
67A4C5	½"-13	Nyloc			

SAE/Inch Capscrews Grade Identification

Grade identification markings are normally stamped on the heads of capscrews, however these marks may vary slightly from manufacturer to manufacturer.				
SAE Grade	1 or 2	5	6 or 7	8
		 	 	
QUALITY OF MATERIAL	MATERIAL INDETERMINATE	MINIMUM COMMERCIAL	MEDIUM COMMERCIAL	BEST COMMERCIAL
USAGE	UNACCEPTABLE	PREFERRED	ALTERNATE IF PREFERRED NOT AVAILABLE	*

*Due to their material and hardness, grade 8 capscrews are not suitable for use on the *pressurized air systems* on an Ingersoll-Rand Portable Air Compressor. On uses other than pressure application, grade 8 capscrews are acceptable.

Table 2

Part Number	ISO/Metric Screws Size (mm)	Description	Part Number	Size (mm)	Description
35271139	M12 x 1.75 x 40	Hex Head, Class 8.8	35330539	M12 x 1.75 x 100	Hex Head, Class 8.8
35271147	M12 x 1.75 c 30	Hex Head, Class 8.8	35353978	M10 x 1.25 x 50	Hex Head, Class 8.8
35271154	M10 x 1.50 x 30	Hex Head, Class 8.8	35356518	M20 x 2.5 x 90	Hex Head, Class 8.8
35271162	M8 x 1.25 x 30	Hex Head, Class 8.8	35358266	M10 x 1.5 x 160	Hex Head, Class 8.8
35271188	M10 x 1.5 x 25	Hex Head, Class 8.8	35358274	M16 x 2.25 x 25	Hex Head, Class 8.8
3527533	M12 x 1.75 x 35	Hex Head, Class 8.8	35361807	M16 x 2.25 x 120	Hex Head, Class 8.8
35272541	M16 x 2.25 x 40	Hex Head, Class 8.8	92304385	M10 x 1.5 x 16	Hex Head, Class 8.8
35273408	M8 x 1.25 x 20	Hex Head, Class 8.8	92304393	M10 x 1.5 x 20	Hex Head, Class 8.8
35273416	M8 x 1.25 x 25	Hex Head, Class 8.8	92304419	M10 x 1.5 x 40	Hex Head, Class 8.8
35273945	M10 x 1.5 x 55	Hex Head, Class 8.8	92304435	M12 x 1.75 x 25	Hex Head, Class 8.8
35275007	M6 x 1 x 25	Hex Head, Class 8.8	92304450	M12 x 1.75 x 50	Hex Head, Class 8.8
35279025	M8 x 1.25 x 20	Self-Tapping	92329309	M10 x 1.5 x 35	Hex Head, Class 8.8
35284678	M8 x 1.25 x 20	Hex Head, Class 8.8	92341239	M20 x 2.5 x 40	Hex Head, Class 8.8
35284793	M8 x 1.25 x 70	Hex Head, Class 8.8	92367663	M16 x 2.25 x 35	Hex Head, Class 8.8
35285584	M12 x 1.75 x 25	Hex Head, Class 12.9	92368687	M6 x 1 x 72	Hex Head, Class 8.8
35287648	M8 x 1.25 x 16	Hex Head, Class 8.8			
35288422	M8 x 1.25 x 80	Hex Head, Class 8.8			
35291640	M14 x 2 x 40	Hex Head, Class 8.8	Part Number	ISO/Metric Nuts Size (mm)	Description
35290113	M16 x 2.25 x 75	Hex Head, Class 8.8	35273366	M10 x 1.5	Lock, Nylon Insert
35295013	M10 x 1.5 x 70	Hex Head, Class 8.8	35275023	M8 x 1.25	Lock, Nylon Insert
35295351	M10 x 1.5 x 25	Hex Head, Class 8.8	35304047	M12 x 1.75	Lock, Nylon Insert
35295484	M12 x 1.75 x 16	Hex Head, Class 8.8	35356526	M20 x 2.5	Lock, Nylon Insert
35295757	M12 x 1.75 x 20	Hex Head, Class 8.8	35361815	M16 x 2.0	Lock, Nylon Insert
35300623	M16 x 2.25 x 140	Hex Head, Class 8.8	90103839	M16 x 2.0	Hex
35300771	M6 x 1 x 20	Self-Tapping	90103854	M12 x 1.75	Hex
35301746	M12 x 1.75 x 55	Hex Head, Class 8.8	92304500	M6 x 1	Hex
35307818	M6 x 1 x 10	Hex Head, Class 8.8	92304526	M10 x 1.5	Hex
35309715	M16 x 2.25 x 25	Hex Head, Class 8.8			
35317106	M6 x 1 x 25	Hex Head, Class 8.8	Part Number	ISO/Metric Washers Size (mm)	Description
35317148	M8 x 1.25 x 60	Hex Head, Class 8.8	35317114	6	Flat
35321520	M16 x 2.25 x 30	Hex Head, Class 8.8	92304658	6	Spring Lock
35322908	M6 x 1 x 20	Hex Head, Class 8.8	92304674	10	Flat
35327550	M8 x 1.25 x 70	Hex Head, Class 8.8			

**ISO/Metric Capscrews
Grade Identification**

Capscrews shall be identified with their property class symbol with the manufacturer's identification symbol at his option. Grade identification markings (8.8, etc.) are normally located at the top of the screw head, or alternatively, on the side of the head, and may either be raised or depressed at option of the manufacturer.

CLASS	4.6	5.8	8.8	9.8	10.9	12.9
SAE EQUIVALENT	EQUIVALENT TO SAE GRADE 1	EQUIVALENT TO SAE GRADE 2	EQUIVALENT TO SAE GRADE 5	APPROXIMATELY 9 PER CENT STRONGER THAN SAE GRADE 5	EQUIVALENT TO SAE GRADE 8	NO EQUIVALENT SAE GRADE
USAGE	UNACCEPTABLE	UNACCEPTABLE	PREFERRED	ALTERNATE IF PREFERRED NOT AVAILABLE	*	*

*Due to the material and hardness, class 10.9 and 12.9 capscrews are not suitable for use on the pressurized air systems on an Ingersoll-Rand Portable Air Compressor. On uses other than pressure applications, class 10.9 and 12.9 capscrews are acceptable.

